

OUR 64TH YEAR

BEST OF THE WEST
COLLECTOR'S EDITION

JANUARY 2017

TRUE WEST

HISTORY OF THE AMERICAN FRONTIER

THE 100 BEST Historical Photos OF THE AMERICAN FRONTIER

THE EXTRAORDINARY VISION OF AMERICA
BY THE EARLIEST PHOTOGRAPHERS TO
EXPLORE THE WEST

Including

- MOUNTAIN MEN WITH CAMERAS
- THE FIRST PHOTO OF YOSEMITE
- THE EARLIEST KNOWN IMAGE OF AN INDIAN CAMP
- THE 1872 PHOTO OF OLD FAITHFUL ERUPTING 150 FT.
- INCREDIBLE PHOTOS TAKEN FROM GREAT HEIGHTS

\$5.99 • TrueWestMagazine.com





**WESTERN
SPIRIT**
SCOTTSDALE'S
MUSEUM
OF THE WEST

The Artists of Taos

Exhibition: January 10 – April 30, 2017 ♦ Symposium: April 6 – 7, 2017

Sponsored by  **SCOTTSDALE
ART AUCTION**

A major exhibition featuring many of the finest artworks by members of the Taos Society of Artists — one of the most influential and highly acclaimed artist groups in the nation's history

Julius Rolshoven, *The Council*, ca. 1916-17, oil on paper, mounted on board; Courtesy the Peterson Family Collection.



Smithsonian Affiliate

3830 N. Marshall Way ♦ Scottsdale, Arizona ♦ 480-686-9539 ♦ scottsdalemuseumwest.org

FOR A NEW LOOK AT THE OLD WEST

In 1881 *The Tombstone Epitaph* reported the Gunfight at the O.K. Corral. Today, Wyatt Earp and Doc Holliday live on in *The Tombstone Epitaph*, now an historical monthly journal of the Old West still published in Tombstone, AZ.

Twenty pages of newly researched articles on the winning of the Old West every month:

- HISTORIC EVENTS
- FRONTIERSMAN & GUNSLINGERS
- THE FAMOUS & THE INFAMOUS
- COWBOYS & INDIANS
- PIONEER WOMEN & FAMILIES
- RARE PHOTOGRAPHS



Send this coupon with your subscription to get a FREE reprint of the 1881 Epitaph reporting the Gunfight at the O.K. Corral®. Or subscribe online at www.tombstoneepitaph.com

ONLY \$25 PER YEAR

The Tombstone Epitaph.

Name _____

Address _____

City _____ State _____ Zip _____

Send check or money order to: The Tombstone Epitaph
P.O. Box 1880, Tombstone, AZ 85638.

Rates U.S.: 1-Year \$25 2-Year \$45 3-Year \$60



FAMOUS GUNFIGHT SITE

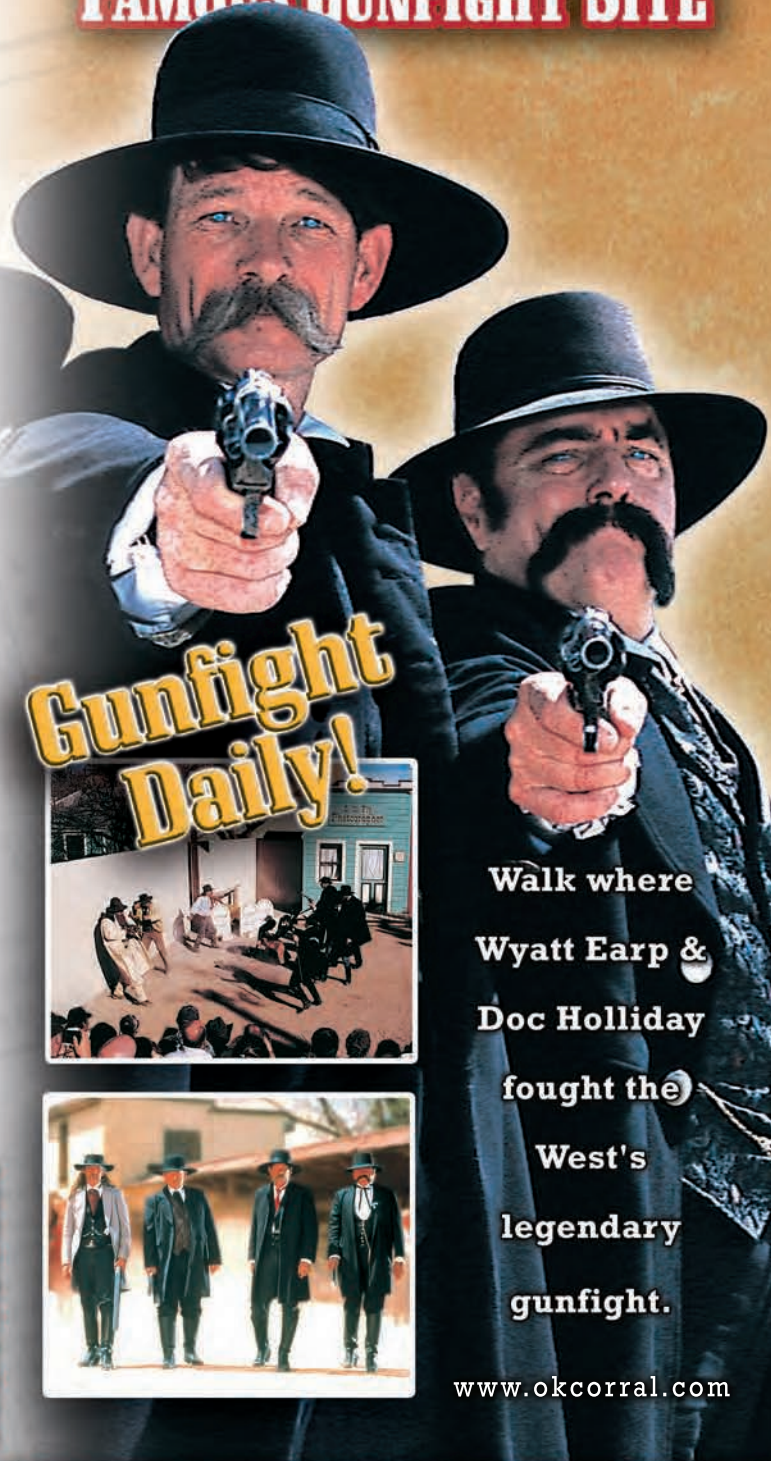

Walk where
Wyatt Earp &
Doc Holliday
fought the
West's
legendary
gunfight.

www.okcorral.com

TOMBSTONE, ARIZONA

Sixty-five Miles S.E. of Tucson

Cowboy Legacy

A GALLERY OF THE WESTERN LIFESTYLE

Antique & Contemporary

Saddles • Bits • Spurs • Fine Art • Indian Artifacts



480.595.8999

BillCowboyLegacy@aol.com

7077 E. Main St #10 • Scottsdale AZ 85251

proprietor Bill Welch

Reputation matters.



Historic Custer Battlefield Rifle.
(Details upon request)



Keystone Bros. San Francisco Exhibition Saddle
(est. \$70,000-90,000)



SHOW & AUCTION
JANUARY 21-22, 2017
MESA, ARIZONA

WESTERN AMERICANA ANTIQUE SHOW

Weekend Shopping Event!

Over 150 national dealers

Saturday, January 21, 9:00 am - 4:00 pm

Sunday, January 22, 9:00 am - 3:00 pm

\$10 daily or purchase online and save:

OldWestEvents.com/purchase-tickets

SHOW LOCATION

Show Location:

Mesa Convention Center

263 N. Center Street, Mesa, AZ 85201

WESTERN AMERICANA AUCTION

Saturday, January 21, 5:00 pm

Preview Hours:

Thursday, January 19, 2:00 pm - 6:00 pm

Friday, January 20, 9:00 am - 5:00 pm

Saturday, January 21, 9:00 am - 4:30 pm

Purchase catalogs online:

OldWestEvents.com/catalogs

AUCTION LOCATION

Phoenix Marriott Mesa

200 N. Centennial Way, Mesa, AZ 85201

Next door to the show

PH: 480-779-WEST (9378) | FAX: 855-779-WEST (9378) | ContactUs@OldWestEvents.com

OldWestEvents.com

OPENING SHOT

WE TAKE YOU THERE





1 Harry Yount at Berthoud Pass

Harry Yount sits at Berthoud Pass, in the Rocky Mountains of central Colorado, in the above 1874 photograph taken by William H. Jackson during the Ferdinand V. Hayden Survey. Six years later, Yount (also shown in inset) became the first and only gamekeeper for Yellowstone National Park. He is credited as the first national park ranger (some debate Galen Clark was actually the first); Yount pointed out how impossible it was for one man to patrol the park and urged the government to form a ranger force.

- COURTESY USGS -





True West captures the spirit of the West with authenticity, personality and humor by providing a necessary link from our history to our present.

EDITORIAL

EXECUTIVE EDITOR: Bob Boze Bell

EDITOR: Meghan Saar

SENIOR EDITOR: Stuart Rosebrook

FEATURES EDITOR: Mark Boardman

EDITORIAL TEAM

Copy Editor: Beth Deveny

Firearms Editor: Phil Spangenberg

Westerns Film Editor: Henry C. Parke

Military History Editor: Col. Alan C. Huffines, U.S. Army

Preservation Editor: Jana Bommersbach

Social Media Editor: Rhiannon Deremo

PRODUCTION MANAGER: Robert Ray

ART DIRECTOR: Daniel Harshberger

GRAPHIC DESIGNER: Rebecca Edwards

MAPINATOR EMERITUS: Gus Walker

HISTORICAL CONSULTANT: Paul Hutton

CONTRIBUTING EDITORS

Tom Augherton, Allen Barra, Leo W. Banks,

John Boessenecker, Johnny D. Boggs,

Drew Gomber, Kevin Kibsey, Sherry Monahan,

Candy Moulton, Frederick Nolan, Gary Roberts,

Marshall Trimble, Linda Wommack

ARCHIVIST/PROOFREADER: Ron Frieling

PUBLISHER EMERITUS: Robert G. McCubbin

TRUE WEST FOUNDER: Joe Austell Small (1914-1994)

ADVERTISING/BUSINESS

PRESIDENT & CEO: Bob Boze Bell

PUBLISHER & CRO: Ken Amoroso

GENERAL MANAGER: Carole Compton Glenn

ASSOCIATE PUBLISHER: Dave Dais

SALES & MARKETING DIRECTOR: Ken Amoroso

REGIONAL SALES MANAGERS

Greg Carroll (greg@twmag.com)

Arizona, California, Idaho, Iowa, Kansas,

Nevada & Washington

Cynthia Burke (cynthia@twmag.com)

Montana, New Mexico, North Dakota, Oklahoma,

South Dakota, Utah & Wyoming

Sheri Riley (sheri@twmag.com)

Colorado, Minnesota, Missouri, Nebraska, Oregon,

Tennessee & Texas

ADMINISTRATIVE ASSISTANT: Samantha Shores

January 2017, Vol. 64, #1, Whole #564. True West (ISSN 0041-3615) is published twelve times a year (January, February, March, April, May, June, July, August, September, October, November, December) by True West Publishing, Inc., 6702 E. Cave Creek Rd, Suite #5 Cave Creek, AZ 85331. 480-575-1881. Periodical postage paid at Cave Creek, AZ 85327, and at additional mailing offices. Canadian GST Registration Number R132182866.

Single copies: \$5.99. U.S. subscription rate is \$29.95 per year (12 issues); \$49.95 for two years (24 issues).

POSTMASTER: Please send address change to: True West, P.O. Box 8008, Cave Creek, AZ 85327. Printed in the United States of America. Copyright 2016 by True West Publishing, Inc.

Information provided is for educational or entertainment purposes only. True West Publishing, Inc. assumes no liability or responsibility for any inaccurate, delayed or incomplete information, nor for any actions taken in reliance thereon.

Any unsolicited manuscripts, proposals, query letters, research, images or other documents that we receive will not be returned, and True West Publishing is not responsible for any materials submitted.

SUBSCRIPTIONS, RENEWALS AND ADDRESS CHANGES

888-687-1881

FAX: 480-575-1903

Follow us on:



True West Online >

TrueWestMagazine.com

January 2017 Online and Social Media Content

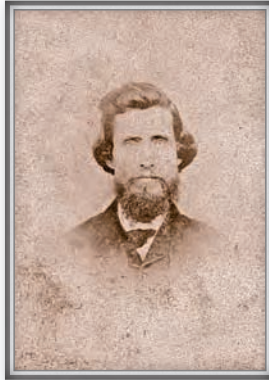

Join the Conversation

In response to Mark Boardman's blog post about Granville Stuart, True West Facebook follower Terry D. Baddley of Brigham City, Utah, contributed this photo of the "Gentleman Vigilante."



Go behind the scenes of True West with Bob Boze Bell to see his painting, *Over Treacherous Trails*, and more of the executive editor's Daily Whipouts (Search for "October 24, 2016").
Blog.TrueWestMagazine.com



This buckskin-clad hunter proudly poses with a bear and his weapon that no doubt killed it—a Sharps Model 1874 sporting rifle, made in Bridgeport, Connecticut. Find this and more historical photography on our "Firearms" board.

Pinterest.com/TrueWestMag

— COURTESY DICKINSON RESEARCH CENTER, NATIONAL COWBOY & WESTERN HERITAGE MUSEUM, 1994.10.1744 —



- 4** OPENING SHOT
- 8** SHOOTING BACK
- 9** TO THE POINT
- 10** TRUTH BE KNOWN
- 12** INVESTIGATING HISTORY
- 14** OLD WEST SAVIORS
- 16** FRONTIER FARE
- 18** CLASSIC GUNFIGHTS
- 22** UNSUNG
- 121** WESTERN ROUNDUP
- 126** ASK THE MARSHALL
- 128** WHAT HISTORY HAS TAUGHT ME



Cover design by Dan Harshberger

THE 100 BEST Historical Photos OF THE AMERICAN FRONTIER

24



26 A MAN OF MANY FIRSTS

Joseph Rutherford Walker blazed trails in the nation's first government surveys.

—By Kate Ruland-Thorne

30 HAYDEN'S HALLOWED EXPEDITION

The 150th anniversary of the birth of the American West's four major surveys.

—By Thomas P. Huber

48

ART AND COLLECTIBLES

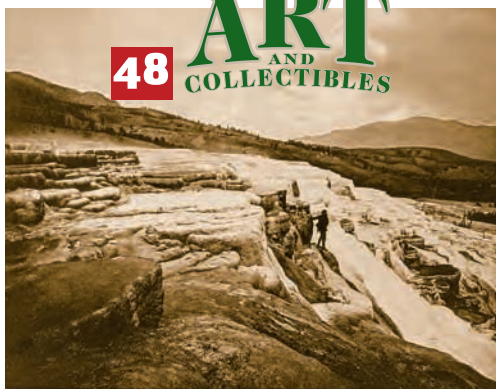

TRUE WEST BEST OF THE WEST TWO THOUSAND SEVENTEEN

46

FIREARMS

71

WESTERN WEAR

87



WESTERN BOOKS

56

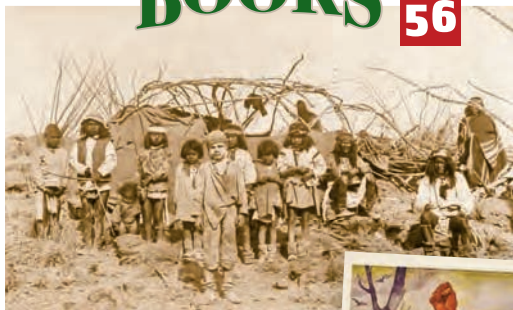

WESTERN MOVIES DVDS & TV SHOWS

80



HERITAGE TRAVEL

92





COURTESY METRO-GOLDWYN-MAYER STUDIOS & COLUMBIA PICTURES

MAGNIFICENT ENTERTAINMENT

I take issue with Henry C. Parke's review of the new *Magnificent Seven* movie starring Denzel Washington [November 2016]. He calls the film "less than magnificent" and "flat." He also finds the actors disappointing. I found just the opposite to be true. I found the acting great, the scenery stunning and the action ongoing and exciting. There were also some good comedic moments. My wife and I found this to be a good old-fashioned Western. I urge your readers to go watch this film at the theater, and I feel that they will be pleased. I have watched hundreds, maybe even thousands, of Westerns, and this Western is very entertaining and enjoyable. Heck, my wife even clapped with appreciation when the film ended! The Western is alive and well!

Bob Cochran
Fort Madison, Iowa

LAST VISIT WITH JOAQUIN

My thanks for including a piece on Texas Ranger Joaquin Jackson [December 2016]. He contributed an element of historical context to our already rich Texas Ranger history here in west Texas. And most important, he was a friend—he made you feel special, and he closed his writings with "Su amigo siempre."

Big Bend National Park owes its founding to a former Texas Ranger, E.E. Townsend, who, in 1894, discovered its grandeur while trailing mule thieves through the wilderness. It was a life-changing event for Townsend, and he dedicated 50 years to making the park a reality. Other Texas Rangers who were impacted by the area included John Coffee "Jack" Hays, who nearly starved to death while searching for a southern trade route in 1848 (the Hays-Highsmith Expedition). Rangers Charles Neville and Capt. Jim Gillette also influenced the personality of the area. I asked Joaquin if I could include him in an interpretive program about these Texas Rangers and their stories of taming the last frontier, and he said he felt honored to be included with these proud lawmen.

As a personal note, I was a young buck growing up in Carrizo Springs, Texas, when Joaquin was a rookie Ranger working under Capt. A.Y. Allee. When Allee brought these handsome newly recruited lawmen to town, all the young ladies swooned, leaving us town boys green with envy. During my last visit with Joaquin, we laughed at those early years. He left one hell of a story.

Rob Dean
Terlingua, Texas

CALIFORNIA CALAMITY

Great article about the San Francisco 1906 Earthquake and Fire [November 2016]. Keep them coming! However, the captioned photo of the burnt out city [below] states, "The destruction hits home in this photo of Grant Avenue toward Yerba Buena Island."

The street in question is actually California Street, which runs downhill in this eastward-looking photo, not Grant Avenue. California Street runs east-west, while Grant Avenue runs north-south. (Grant Avenue is actually just in front of the burned out shell of St. Mary Cathedral at the extreme left of the photo. Across California Street, on the southeast corner of Grant [formerly Dupont], is the spot where "Emperor" Norton—featured in your December 2016 issue—died in 1880).

This classic photo clearly shows the cable car tracks running the length of California Street; Grant Avenue never had cable car tracks.

James "Crimp" Jarvis
San Francisco, California

Editors: Thank you for writing in to share your local knowledge! The Chicago Tribune and the Associated Press have published this historical photograph with those details, so we appreciate you helping us get this correct!



TRUE WEST ARCHIVES

LONG MAY HE RIDE

Thank you for honoring Hugh O'Brian [December 2016]. Having attended a number of the magazine's events in the Cave Creek area of Arizona over the years, I know that Hugh O'Brian and his role as Wyatt Earp were important to you. I am sorry for the loss. I grew up during the era of Westerns, and these classics all mean a lot to me. He was one of the good guys.

Bruce Howard
Scottsdale, Arizona

The Man Collectors Trust

The 2017 True Westerner award goes to Brian Lebel.

Brian Lebel has had his hands on some pretty amazing Western history. He is the guy who brought *the* Billy the Kid tintype to the *True West* offices, in the spring of 2011, and allowed us to hold it in our hands. What a day that was! When you hold the real photo, you can see so many things. It's downright emotional.

And, of course, Brian was the one who facilitated the auction of that tintype. His Old West Auction sold the one-and-only Kid photograph to William Koch for \$2.3 million.

Brian has also handled Tom Horn's Winchester, the gun that killed Morgan Earp, Annie Oakley's wedding ring and an original reward poster for Frank and Jesse James. He's seen up close and personal a ton of valuable artwork, gear and saddles that were showcased in his collectibles show, held along with the auction, in his nearly 30-year career. The list goes on and on.

Old West history collectors turn to him now more than ever. In 2014, the 25th anniversary year of his Old West event, Brian and his wife, Melissa, acquired High Noon Show & Auction, held every January in Mesa, Arizona. He is certainly doing all he can to help preserve and present America's frontier history through the arts and artifacts of the American West.

It gives me great pleasure to bestow upon Brian our highest honor, True Westerner of the Year. On January 21, *True West* will present the True Westerner statue to Brian at Western Spirit: Scottsdale's Museum of the West, this year's Best Western Museum. For more of the year's Best, read on!



Brian Lebel (left) believes more people will appreciate great Old West artifacts so long as they are aware of what is available. This is why he launched his own auction, and he has been the guy collectors go to ever since.

- COURTESY BRIAN LEBEL -



2 Blackfoot Chiefs on the Northern Plains

In the footsteps of the West's earliest photographers, Edward S. Curtis hoped to capture the disappearing frontier. Through his Old West Auction, Brian Lebel got this circa 1900 Curtis photograph, "Three Chiefs Piegan," into the hands of an appreciative collector, who paid nearly \$12,000 for the original platinum print.

- COURTESY BRIAN LEBEL'S OLD WEST AUCTION, JUNE 24, 2004 -

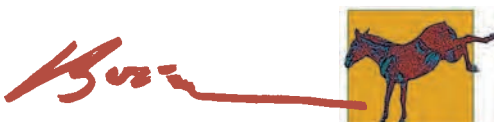

For a behind-the-scenes look at running this magazine, check out BBB's daily blog at TWMag.com

Quotes

“Place and people are made familiar to us by means of the camera in the hands of skillful operators, who, vying with each other in the excellence of their productions, avail themselves of every opportunity to visit interesting points, and to take care to lose no good chance to scour the country in search of new fields for photographic labor.”

– Timothy O’Sullivan, Irish-American photographer

“Only photography has been able to divide human life into a series of moments, each of them has the value of a complete existence.”

– Eadweard Muybridge, British-American photographer

“You press the button—we do the rest.”

– Kodak camera 1889 advertisement

“In wisdom gathered over time I have found that every experience is a form of exploration.”

– Ansel Adams, American photographer

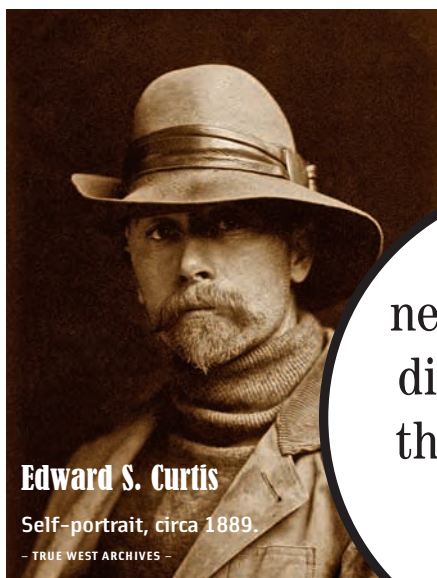

Edward S. Curtis

Self-portrait, circa 1889.

– TRUE WEST ARCHIVES –

“For every negative that is a disappointment, there is one that is a joy.”

– Edward S. Curtis, American photographer

Bizarro BY DAN PIRARO



“And if any work that I have done should have value beyond my own lifetime, I believe it will be the happy labors of the decade 1869-1878.”

– William Henry Jackson, American photographer



3 William Henry Jackson

Self-Portrait on Mount Washburn, Yellowstone, 1871.

– COURTESY NATIONAL PARK SERVICE –

Old Vaquero Saying



“Life is like photography, we use the negatives to develop.”

The Heart of the Big Bend Country

Study Butte/Terlingua is located three miles from the park entrance.

We offer five motels, several restaurants, medic's, post office, bank, gas station, a great quilt shop, art galleries, assorted gift shops, and wonderful night life.

Big Bend Chamber of Commerce and Visit Big Bend: 432-371-2320

visitbigbend.com or bigbendchamberofcommerce.org



BY MARK BOARDMAN

Buffalo Bill Lies Here—Or Here

Two sites continue the fight over the Wild West showman's grave.

William F. Cody—Buffalo Bill—was arguably one of the great showmen of all times. He would probably enjoy the ongoing public spectacle about where he's buried.

Here's what historians know, they think. Cody, the master of the Wild West show, died of kidney failure while visiting his sister in Denver, Colorado, on January 10, 1917. The old boy was just short of 71 when the curtains closed. His wife had him buried on top of Lookout Mountain, west of Denver. And that should have been that.

But no. Cody's 1906 will stated he was to be interred on Cedar Mountain, outside Cody, Wyoming. A later will, dated 1913, let Cody's widow decide his final resting place; she chose Colorado, saying that Buffalo Bill had told her he wanted to spend eternity there. Cody's niece, Mary Jester Allen, disputed that, saying Denver paid the widow \$10,000 to move the gravesite. Wyoming officials were outraged, and people made threats to steal the corpse and take it north.

Who would spirit Buffalo Bill's body to his namesake town?

They had an opportunity to do just that, because Cody's burial had to be delayed. The Lookout Mountain ground was frozen at the time of Cody's death and his body was kept—under guard—at a local funeral home until the ground warmed.

On June 3, the remains were encased in a concrete vault atop the mountain (Mrs. Cody died in 1921 and was later buried in the same vault, on top of her husband—with a bit more concrete added



Despite helping drive the showman to financial ruin, *The Denver Post* owner Harry Tammen paid for Buffalo Bill Cody's elaborate funeral in Denver, Colorado.

— COURTESY LIBRARY OF CONGRESS —

for good measure). That wasn't the end of the burial contest, though.

Zoom forward to 1948. American Legion members in Cody offered \$10,000 to anybody who would spirit Buffalo Bill's body to his namesake town. The Colorado National Guard responded by stationing troops around the burial site. And in 2006, Wyoming state legislators—as a joke—debated a proposal to dig up Cody.

There's more.

Some folks in Wyoming believe that Cody was buried in their state. According to one conspiracy theory, people snuck into the funeral home where his body was kept, switched it with that of a similar looking vagrant and took the Cody corpse to Cedar Mountain. No evidence proves that occurred;

in fact, thousands of people—including family and close friends—saw Cody's remains just before the interment.

Steve Friesen, the director of the Buffalo Bill Museum and Grave in Golden, Colorado, just laughs over the entire thing. In a July 2015 *Los Angeles Times* article, he suggested that Wyoming folks have too much time on their hands. Bruce Eldredge, executive director and CEO of the Buffalo Bill Center of the West in Cody, Wyoming, diplomatically says he's not surprised the two states both claim the man.

If nothing else, the whole fandango gives the Buffalo Bill buff a reason to visit both Lookout Mountain and Cody. Buffalo Bill's around there, somewhere....





Travel Back in Time and Experience
the Most Exciting Old West Adventure in Colorado

The Most Exciting Day Trip

Imagine taking a day trip back to the 1880's on America's Highest and Longest Narrow Gauge Railroad! Join us for the trip of a lifetime and take a ride through history from Antonito, Colorado.

COLORADOMOUNTAINTRAIN.COM



TOLL FREE: 1.888.286.2737

CUMBRES & TOLTEC
SCENIC RAILROAD
NATIONAL HISTORIC LANDMARK



**VOTED #1 BEST TRAIN RIDE IN AMERICA
BY USA TODAY READERS!**

TRAINS DEPART DAILY MAY 27 – OCTOBER 22, 2017.

BY JANA BOMMERSBACH

Crown City's Old Vistas

Coronado Island showcases its sweeping history in incredible art murals.



Coronado Island tourists talk with the artist, Todd Stands (sitting at far left), about his art collages of historical photographs (see detail above right) that bring to life the swim-and-sun-worshipping people who enjoyed adventures in the resort destination.

— STANDS AT TENT CITY MURAL PHOTO BY JANA BOMMERSBACH; CITY HALL MURAL DETAIL COURTESY CITY OF CORONADO —

Box after box of photos. Day after day. One image more fabulous than the next.

Photographer Todd Stands thought he knew a lot about “Coronado Island,” as it’s usually called, but after viewing “tens of thousands” of photographs supplied by the Coronado Historical Association, he saw the California city in a new light.

The City of Coronado was building a new City Hall and wanted to commemorate the rich history of this resort town next to San Diego, founded in the late 1800s and named after the Spanish word meaning “crowned one.”

The city commissioned Stands to create giant collages of historical photos to cover the north and south walls of City Hall’s lobby, making it into a permanent art gallery.

Stands spent weeks choosing 500 images and a month scanning them into a computer. Then he set to work.

“I had hundreds of incredible images,” he recalls. “I’d think, ‘I need a plane,’ and find

one, then think, ‘Hey, I’ve got a better plane.’ I made thousands of collages. I would bring them in to city officials for all to see. The hardest part for any public arts project is getting everyone on the same page.”

He produced nine foot-by-18 foot murals. The one on the north wall has 45 photos; for the south wall, 57. Just 102 pictures in all, installed in 2005. But what a story they tell.

The north collage, titled “Photographic Memory #1,” includes photos of the original boathouse and baths of Hotel del Coronado from 1888-1891—a hotel that is still the most recognizable feature of this community; ferryboats from the late 1800s; golf in 1918; a “Coronado matron at polo match,” circa 1920; the Coronado High School football team from 1923; the dirigible *Shenandoah* from 1924—as well as an amphibious plane and the first hydroplane flown by Glenn Curtiss in 1911.

The south mural, “Photographic Memory #2,” includes pictures of a double-decker

streetcar, circa 1889; the Japanese Tea Garden wishing well from around 1908; the ferry *Ramona*, 1904; the island’s first schoolhouse in 1888; the regatta from 1935; the Boy Scout Liberty Bond drive of 1914; and “Elena Whiley with her clavichord,” 1921.

Both murals include images from “Tent City,” which stood from 1900 to 1939 adjacent to “The Del,” and housed folks who couldn’t afford the hotel’s high prices. The city officials commissioned Stands to do a second mural project on Tent City, with photos printed on glazed tiles for an outdoor display. The mural panels were installed in 2009, on the very site where Tent City once stood—now the Glorietta Bay Promenade.

Stands says he’s proud of all the collages he created: “They give people a visual of the depth of this place.”

Jana Bombersbach has earned recognition as Arizona’s Journalist of the Year and won an Emmy and two Lifetime Achievement Awards. She cowrote the Emmy-winning *Outrageous Arizona* and has written two true crime books, a children’s book and the historical novel *Cattle Kate*.

JOHN WAYNE: WESTERN GREAT

COLD-CAST BRONZE MASTERPIECE SCULPTURE



Shown smaller than
actual size of
13½ inches high.

- ★ Cold-cast bronze sculpture captures Duke's stance and appearance to perfection
- ★ Hand-finished and hand-burnished for authentic antique bronze look
- ★ Gallery-quality edition inspired by classic works of Western artists Frederic Remington and Charles M. Russell
- ★ Mahogany-finished base; includes hand-numbered Certificate of Authenticity

An exceptional value;
satisfaction guaranteed.

Strong demand is likely for this limited-edition tribute with the rich luster of the finest bronze, so act now to acquire the *John Wayne: Western Great Cold-Cast Bronze Masterpiece Sculpture* at issue price, payable in four installments of \$37.49 for a total of \$149.95*. Your purchase is risk-free, backed by our 365-day money-back guarantee. Send no money now. Just return the Reservation Application today!

JOHN WAYNE, , DUKE and THE DUKE are the exclusive trademarks of, and the John Wayne name, image, likeness and voice, and all other related indicia are the intellectual property of, John Wayne Enterprises, LLC. ©2016. All rights reserved. www.johnwayne.com

www.bradfordexchange.com/jwgreat

©2016 BGE 01-17898-002-BIR

RESERVATION APPLICATION

SEND NO MONEY NOW

THE
BRADFORD EXCHANGE
—HOME DECOR—

9345 Milwaukee Avenue · Niles, IL 60714-1393

YES. Please reserve the *John Wayne: Western Great Cold-Cast Bronze Masterpiece Sculpture* for me as described in this announcement.

Limit: one per order.

Please Respond Promptly

Mrs. Mr. Ms.

Name (Please Print Clearly)

Address

City

State

Zip

01-17898-002-E22891

*Plus \$19.99 shipping and service. Limited-edition presentation restricted to 295 casting days. Please allow 4-8 weeks after initial payment for shipment. Sales subject to product availability and order acceptance.

BY SHERRY MONAHAN

Denver's Unsinkable Hostess

Molly Brown found acceptance among frontier Denver's high society.



These ladies in Denver, Colorado, enjoy an elegant meal. Margaret Brown found acceptance with the upper crust, although some still pricked her honor. When she had German craftsmen create a "silver lunch wagonette," which could be wheeled from room to room to offer guests tea, coffee and small dishes, some socialites made fun of her.

— COURTESY BROWN PALACE ARCHIVES —

Before she became famous as the "Unsinkable Molly Brown," after surviving the 1912 sinking of *Titanic*, Margaret Tobin-Brown arrived in Denver, Colorado, when elegant entertaining was at its height on Capitol Hill. In 1894, she and her husband, James, bought an extravagant home, in the fashionable neighborhood on Pennsylvania Street, purchased with his newly acquired mining money.

Within a few years, Denver's high society accepted the Hannibal, Missouri, native into social circles. By 1897, the community showcased her among the "Urban Beauties" in the parade at the Festival of Mountain and Plain. On June 22, 1898, Margaret hosted one of the many luncheon parties held during Denver's biennial week. The governor's wife, Mrs. Alva Adams, was among her guests.

The following year, Margaret moved to Paris, France. When she returned to Denver after her year-long trip, at the turn of the

20th century, she became well-known for her parties. *The Denver Post* reported, "One always looks for beauty of arrangement and general details when Mrs. James J. Brown comes forward as a hostess...."

Denver's high society standards reflected the Victorian times in which they lived. Expensive invitations were mailed or delivered. Parties and balls included anywhere from 50 to several hundred guests. Luncheons and dinners required written invitations, but were more intimate affairs. And parties commonly had a theme, such as the card party thrown by Mrs. Robert Levy with a Halloween theme. Golden pumpkins bloomed with golden chrysanthemums and masses of ferns. She served a "dainty" luncheon of ices, cakes and confections—all in fall colors and shapes.

In the late 1890s, the *Post* printed recipes for entertaining. A party's menu could include sweetbread patties, chicken croquettes, asparagus, Saratoga chips,

Saratoga chips proved trendy during Margaret's party-throwing days.

Elko.

Experience The Unexpected

Nevada

ELKO CONVENTION CENTER

ELKO CONVENTION & VISITORS AUTHORITY
(800) 248-3556

For more information on Elko area events visit:
ExploreElko.com

chocolate, tomato salad, strawberry sherbet and Spanish chocolate cake.

"The first thing to be thought of after the menu has been decided upon," the paper noted, "is how to make the lunch table most attractive.... Put only what is necessary on the table at any time. It is correct to leave salted almonds on the table throughout the meal and they may be eaten at any time."

The paper went on to describe how to serve the meal: "After your guests are seated, have the maid bring the patties to each place, or if the maid is experienced, have one at each place when you sit down. After removing the patties, have a chicken croquet, with short, tender pieces of asparagus beside it, and Saratoga chips, all on one plate, brought to each guest. This leaves only the bread to be passed...."

Margaret once threw a holiday party featuring a table arranged in figure eight form with a water fountain, in a mound of ferns and palms, at the center. A Christmas tree lit up with candles and glittering with ornaments added a festive touch. About 70 guests enjoyed the dinner served on Molly's china, which had green clovers and red berries to reflect her Irish heritage.

Cast yourself into Denver's frontier high society and try the Saratoga chips that proved trendy during Margaret's party-throwing days. ❏

Sherry Monahan has penned *Mrs. Earp: Wives & Lovers of the Earp Brothers*; *California Vines, Wines & Pioneers*; *Taste of Tombstone*; *The Wicked West* and *Tombstone's Treasure*. She's appeared on the History Channel in *Lost Worlds* and other shows.

SARATOGA CHIPS

4 white potatoes
Lard or oil for frying
Salt

Slice the potatoes thin and soak in water for about an hour. Drain and completely dry, as any water will cause the grease to explode and pop. Place enough lard or oil in a Dutch oven to come halfway up the pan and heat to medium-high. Gently add the potatoes in small batches and fry until golden. Place on paper towels to absorb fat. Sprinkle with salt while still hot.



Recipe adapted from *The Evening Post*, Denver, Colorado, May 30, 1895

AT Pro: Better Finds, and Special Savings



Garrett's AT Pro is waterproof to 10 feet!

ATTM PRO BONUS PACK

PN: 1140461

Includes:

- AT Pro metal detector with 8.5" x 11" DD searchcoil
- Garrett Master SoundTM Headphones
- Instructional DVD
- **Garrett Camo Backpack**
- **Garrett Camo Digger's Pouch**
- **8.5" x 11" Coil Cover**
- **Garrett Camo AT Pro Cap**

**BONUS
ITEMS**

Save
\$96^{80*}



* AT Pro MSRP \$699.95. Savings based on total cost of detector and accessory items if purchased separately. Accessories items are subject to change. Available at participating U.S. dealers from September 1 to December 31, 2016.

GARRETT[®]

METAL DETECTORS

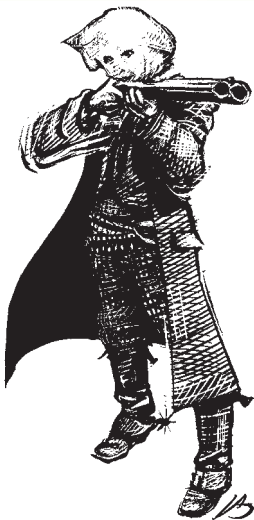

Visit garrett.com to find your nearest dealer

TRUE WEST
EXCLUSIVECLASSIC
GUNFIGHTSBLACK BART'S
BAD DAYBLACK BART
VS
REASON
McCONNELL
& JIMMY ROLLERITHINGS GET FUNKY
ON FUNK HILL

"I've labored long and hard for bread
For honor and for riches
But on my corns too long you've tread
You fine haired sons of bitches."

—Black Bart, the PoB

—ILLUSTRATIONS BY BOB BOZE BELL—

BY BOB BOZE BELL

Maps & Graphics by Gus Walker

Based on the research of George Hoepfer and John Boessenecker

It's a Saturday as the Sonora-Milton stage rattles along, empty, save for the driver. Reason E. McConnell has been on the road for three hours since he stopped at the Patterson Mine, near Tuttletown, California, picking up \$4,200 worth of amalgamated gold. The Wells Fargo box also contains \$500 in gold coin and \$64 in raw gold.

McConnell finally reins up in front of the Reynolds Ferry Hotel, nestled along the banks of the Stanislaus River. Jimmy Rolleri, the hotel manager's 19-year-old son, exits the hotel and exchanges the outgoing mail for the incoming. Glancing at the empty coach, Rolleri asks if he can catch a ride up the hill on the opposite side of the river. A traveler who had stopped at the hotel the previous night reported seeing "two big bucks up there on the flat above Yaqui Gulch," he says.

McConnell tells the boy to grab his gun, and Rolleri returns with a "well-worn but serviceable .44 Henry rifle." With the help of Henry Requa, the two successfully ferry the stage across the river. Requa returns the ferry to the hotel side of the river, and Rolleri jumps up on the box with McConnell, who slaps the reins of his team, encouraging them up the steep approach to Funk Hill.

Halfway up the long grade, Rolleri asks McConnell to slow down. He jumps off with his rifle, thanks McConnell for the lift and heads out into the underbrush to hunt for the big bucks.

The six-horse team continues on, struggling up the steep grade for another 30 minutes. As the stage rounds the head of Yaqui Gulch, with the ridge line in sight, the lead horses snort and rear in fright when a lone, hooded figure, shotgun in hand, leaps into the roadway.

Wearing a dirt-smudged duster and a flour sack with eye holes cut into them, the highwayman demands the Wells Fargo box be thrown down. McConnell informs the robber it's bolted down. The outlaw tells the driver to unhitch his team, but McConnell protests, fearing the stage will roll down the hill due to its bad brakes. The robber's solution is for McConnell to

wedge rocks behind the wheels, but the driver brashly pushes his luck by stating, "Why don't you do it?"

Incredibly, the hooded robber keeps his shotgun trained on the driver, picks up several stones and blocks the back wheels. McConnell then unhitches the team and leads it uphill. "If you don't want to get shot," the robber warns him, "don't come back or even look back in this direction for at least one hour."

While leading the team, McConnell hears the robber banging away at the strongbox. Sneaking glances toward the coach, he can't see the brigand, who has probably crawled into the stagecoach.

Two hundred yards from the stage, McConnell stops to catch his breath when downhill movement catches his eye. It's Jimmy Rolleri, the Henry rifle in the crook of his arm, moving across an open swale of land about 300 yards below. Tying his team to an oak tree, McConnell runs downhill as quietly as he can, frantically waving his hat until he gets Rolleri's attention. Coming up the hill, Rolleri first thinks McConnell has discovered the deer. But the driver fills him in on the situation, and the two warily approach the stage with the intent of capturing the outlaw, or killing him. When they get within 100 yards, the bandit suddenly emerges from the stage and spots them. The outlaw throws a sack over his shoulder and starts to run.

McConnell borrows Rolleri's rifle and fires twice, missing the robber both times.

"Here, let me shoot," young Rolleri says. "I'll get him and I won't kill him, either." With Rolleri's shot, the outlaw stumbles, but he vanishes into the underbrush with his booty.

When the county sheriff and a Wells Fargo detective arrive, they discover what the brigand left behind in his hasty retreat: a derby hat, three pairs of cuffs, an opera glass case and a silk crepe handkerchief with the laundry mark "F.X.O.7." on it.

After eight years and 28 successful stage holdups, this last item will prove to be Black Bart's undoing.





A rare photo of the Reynolds Hotel ferry, which leads the stage to a precarious spot on the crest of Funk Hill. Black Bart will revisit the site of his first holdup for his 29th stage robbery attempt.

- COURTESY TUOLUMNE COUNTY ARCHIVES -

When his photo is taken in Stockton, Black Bart quips: "Will that thing go off? I would like to go off myself."



Poetic Justice: Young Jimmy Rolleri (left) fires the shot that wings Black Bart and forces him to leave behind the handkerchief with a laundry stamp—a clue that Wells Fargo Detective Harry Morse (above) parlays into a collar.

- COURTESY RICHARD ROLLERI -



- COURTESY WELLS FARGO BANK -

A Dapper Disguise

Looking more like a banker than a common stage robber, Black Bart cuts a distinguished figure around San Francisco (his hideout), where he poses as a mining investor named Charles Bolton.

The Monday after the stage robbery, Detective Harry Morse begins matching laundry marks from a handkerchief left at the scene with those of the 91 laundry centers in San Francisco. By the afternoon, he has a match. When a nattily-dressed suspect is taken to Wells Fargo headquarters, the agents are shocked as he looks like "anything but a stage robber." By the end of the week, Black Bart confesses and leads officers to the buried gold. He also poses for the above photograph.

By all accounts, the bandit is witty, self-effacing and intelligent. He even writes a letter from prison to Reason McConnell, who he thanks for being such a lousy shot. He ends the warm letter with: "You sir, have my best wishes for an unmolested, prosperous and happy drive through life."

Black Bart's Odd Style

While most stage robbers ride horses for a faster getaway, Bart walks. And unlike most, he acts alone (not an easy task considering the multiple factors to control: the horses, the road, the driver and the passengers). At two of the robbery sites, he leaves zany poetry, signing it: "Black Bart, the Po8."

Wells Fargo officials admit that the bandit poet hit the company 28 times. Although the total amount of money stolen is unknown, here's a listing of his known robberies and amounts taken.

C. Black Bart takes the train from Sacramento to Reno and stays a couple of days. He rides back to Sacramento before moving on to San Francisco, where he is eventually arrested.

A. The first bits of Black Bart's doggerel verse are scribbled on a way bill taken from a Wells Fargo box. The poem is left at the site of robbery number four.

B. After being wounded during robbery number 29, also the site of his first holdup, Black Bart makes his way on foot to Sacramento.

— TRUE WEST MAP BY GUS WALKER —

The Great Stage Robberies

- 1. July 26, 1875, Calaveras County**
Four miles from Copperopolis, California, Charles E. Boles robs the stagecoach en route to Milton. **Taken:** \$160 in gold notes and the contents of a U.S. Mail pouch.
- 2. December 28, 1875, Yuba County**
North San Juan to Marysville, California, stage. **Taken:** Small undetermined amount of cash.
- 3. June 2, 1876, Siskiyou County**
A nighttime robbery on the Roseburg, Oregon, to Yreka, California, route. **Taken:** \$80 and an unknown amount from mail sacks.
- 4. August 3, 1877, Sonoma County**
Between Fort Ross and Duncan Mills, on the Russian River. **Taken:** \$300 in gold coins and a check for \$305. **Poem:** First poem discovered.
- 5. July 25, 1878, Butte County**
The Quincy to Oroville, California, stage. **Taken:** \$379 in coins, a \$200 diamond ring, \$25 silver watch and cash from mail sacks. **Poem:** Second poem found (printed on opposite page).
- 6. July 30, 1878, Plumas County**
The stage from LaPorte to Oroville, California. **Taken:** \$50 in gold nuggets, a silver watch and money from mail sacks.
- 7. October 2, 1878, Mendocino County**
The Cahto to Ukiah, California, stage. **Taken:** \$40 and mail sack contents.
- 8. October 3, 1878, Mendocino County**
The stage from Covelo to Ukiah, California. **Taken:** Undisclosed amount.
- 9. June 21, 1879, Butte County**
The Forbestown to Oroville, California, stage. **Taken:** Undisclosed amount.
- 10. October 25, 1879, Shasta County**
A nighttime robbery on the Roseburg, Oregon, to Yreka-Redding, California, stage. **Taken:** Undisclosed amount from Wells Fargo and \$1,400 from mail pouches.
- 11. October 27, 1879, Shasta County**
The Alturas to Redding, California, stage. **Taken:** Undetermined.
- 12. July 22, 1880, Sonoma County**
The stage from Point Arena to Duncan Mills, California. **Taken:** Undetermined amount. Whether the robber was Black Bart remains a point of contention to this day.
- 13. September 1, 1880, Shasta County**
The Weaverville to Redding, California, stage. **Taken:** A little more than \$100.
- 14. September 16, 1880, Jackson County, Oregon**
The second nighttime robbery of the Roseburg, Oregon, to Yreka, California, stage, occurring one mile north of the state line. **Taken:** Approximately \$1,000.
- 15. September 23, 1880, Jackson County, Oregon**
The Roseburg, Oregon, to Redding, California, stage, robbed three miles north of the border. **Taken:** \$1,000 in gold dust and from mail sack.
- 16. November 20, 1880, Siskiyou County**
Again, the Roseburg, Oregon, to Redding, California, stage—a mile south of the state line shortly after dark. **Taken:** Unknown.
- 17. August 31, 1881, Siskiyou County**
Around one a.m., the third robbery of the Roseburg, Oregon, to Yreka, California, stage. The stage is robbed 10 miles north of Yreka. **Taken:** Wells Fargo loss not disclosed.
- 18. October 8, 1881, Shasta County**
Midnight robbery of the Yreka to Redding, California, stage near Bass Hill. **Taken:** \$60.
- 19. October 11, 1881, Shasta County**
The Alturas to Redding, California, stage stops at Montgomery Creek to make a harness repair and is robbed again. **Taken:** Undisclosed.
- 20. December 15, 1881, Yuba County**
The Downieville to Marysville, California, stage. **Taken:** Wells Fargo reports "small loss."
- 21. December 27, 1881, Nevada County**
The North San Juan to Smartsville, California, stage. **Taken:** Wells Fargo reports a small loss.
- 22. January 26, 1882, Mendocino County**
The stage from Ukiah to Cloverdale, California. **Taken:** Unknown.
- 23. June 14, 1882, Mendocino County**
The Willits to Ukiah, California, stage. **Taken:** Estimated \$300 and mail sack contents.
- 24. July 13, 1882, Plumas County**
Black Bart is foiled by shotgun blasts when he attempts to rob the LaPorte to Oroville, California, stage once more. (A buckshot pellet creases the robber's forehead, leaving a deep scar.)
- 25. September 17, 1882, Shasta County**
The second robbery of the Yreka to Redding, California, stage at Bass Hill. **Taken:** Thirty-five cents from Wells Fargo.
- 26. November 23, 1882, Sonoma County**
The Lakeport to Cloverdale, California, stage, robbed six miles from Cloverdale. **Taken:** \$475 and several mail sacks.
- 27. April 12, 1883, Sonoma County**
Again, the Lakeport to Cloverdale, California, stage. **Taken:** \$32.50 and mail sack contents.
- 28. June 23, 1883, Amador County**
The stage from Jackson to Lone, California. **Taken:** \$750 and mail sack contents.
- 29. November 3, 1883, Calaveras County**
The Sonora to Milton, California, stage is stopped at the site of the first Black Bart holdup in 1875. **Taken:** Possibly \$4,764.

Where He Got the Name

The infamous robber refused to acknowledge that his real name was Charles E. Boles and served his prison term as Charles E. Bolton.

As for the nom de plume “Black Bart,” Boles admitted he got the name from a character in William Henry Rhodes’ “The Case of Summerfield,” an 1871 serial that ran in the *Sacramento Union*. Boles admitted, “when I was casting around for a pseudonym, the name just popped into my head.”

4 Yosemite Road

Many of Black Bart’s exploits occurred just along the western edge of what is now Yosemite National Park. This early photograph by George Fiske shows a horse and buggy near a shack overlooking Yosemite Valley. This road is perhaps indicative of the type used, and exploited, by Black Bart.

— TRUE WEST ARCHIVES —



Reason McConnell was driving a “mud wagon,” like this one, on Funk Hill. It had wider wheels for better traction in the mountains and foothills of California and Oregon.

— TRUE WEST ARCHIVES —

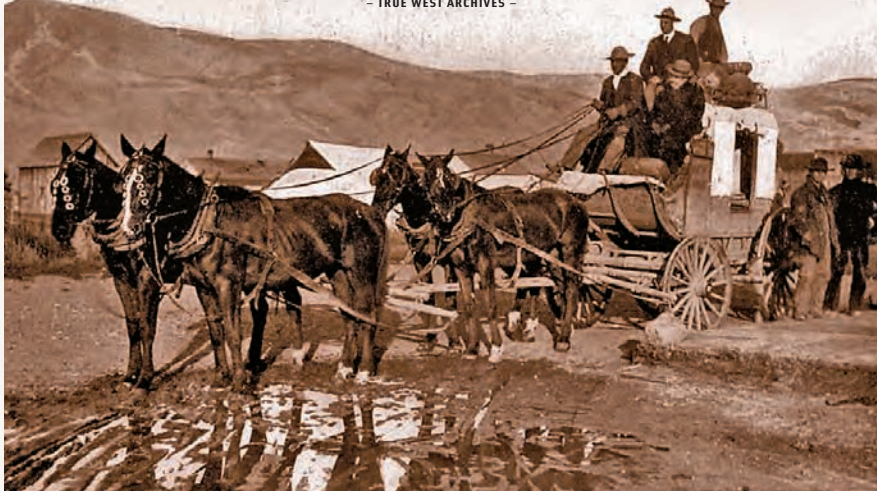

Legendary Poetry

Although Black Bart only leaves two poems at the scenes of his robberies, they contribute to his legendary fame. Some described them as “doggerel,” but one thing is certain: He had an excellent sense of humor.

Here I lay me down to sleep
To wait the coming morrow
Perhaps success perhaps defeat
and everlasting sorrow.
Let come what will. I'll try it on
My condition can't be worse,
But if there's money on the box,
It's munny in my purse.

—*Black Bart, the P o 8.*

Aftermath: Odds & Ends

On November 17, 1883, Charles Bolton, alias Black Bart, pleaded guilty to a single charge of robbery and was sentenced to a remarkably light term of six years in San Quentin. With time off for good behavior, he was released after serving four years and two months.



The newspapers had a field day charging that Black Bart made a deal with the officers in exchange for the stolen gold. Harry Morse suffered the harshest criticism, as the papers questioned his version of the arrest and insisted that an informant had actually led Morse to Bart. One paper, *The San Francisco Examiner*, even questioned whether Boles was Bart.



Wells Fargo paid Morse and Calaveras County Sheriff Ben Thorn the bulk of the \$800 reward. Then Thorn and Morse got into a public spat, accusing each other of malfeasance in the case. Thorn got the final salvo when he publicly reminded Morse of his bragging about an extra-marital affair during their ride from San Andreas to recover the stolen gold. It was a low blow from Thorn, but it worked. Morse never responded.



Black Bart was released from prison in January of 1888. By mid-year, he was back in the news after three more stage holdups, in which Black Bart was named by Jim Hume as the main suspect. Boles disappeared for good. Even his long suffering wife never heard from him again.



Recommended: *Black Bart: Boulevardier Bandit* by George Hoepfer, published by Word Dancer Press; and *Lawman: The Life and Times of Harry Morse, 1835-1912* by John Boessenecker, published by University of Oklahoma Press.

BY SUSAN SCHULTEN

LITTLE KNOWN CHARACTERS OF THE OLD WEST

A Mapmaker's Tragic End

Gouverneur Warren made the first reliable and comprehensive map of the U.S. west of the Mississippi.

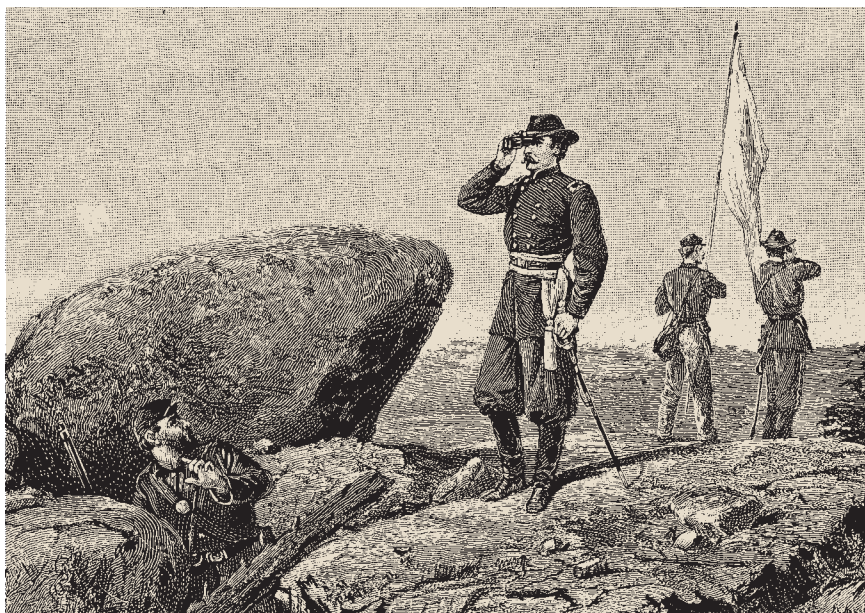

In March 1853, Congress appropriated funding for four surveys of potential railroad routes throughout the American West. The surveys constitute one of the most impressive feats of geographical science in 19th-century America. The reports also contained one of the first detailed maps of the entire West, Lt. Gouverneur Kemble Warren's "Map of the Territory of the United States from the Mississippi to the Pacific Ocean."

Upon graduating from the U.S. Military Academy at West Point in 1850, Warren joined the Corps of Topographical Engineers. He conducted most of his work in 1854, which allowed him to benefit from the extensive reconnaissance knowledge gained from the railroad surveys, as well as his own expeditions through Dakota Territory. The cartographer reconciled conflicting accounts and synthesized disparate geographical information into a single comprehensive view.

Warren took pains to list the dozens of "authorities" who revealed the topography of the West over time, beginning his list with Meriwether Lewis and William Clark, the first agents of the new nation in the American West, rather than with Aaron Arrowsmith, whose British map of the West was the most reliable to that point. Warren's map was a history of official geographical knowledge undertaken in the field, making his map unprecedented.

Yet for all his attention to the genealogy of exploration, Warren downplayed American Indian knowledge, even when his "authorities" relied on it. Such practice was typical. The map of the Missouri Basin that Arrowsmith created incorporated uncredited details drawn by Blackfoot Chief Ackomokki.

Between 1869 and 1879, the federal government mounted more surveys of its Western lands, undertaken by Clarence King, John Wesley Powell, Ferdinand Hayden and

Despite his heroic act at Gettysburg, illustrated here, Gouverneur Warren left Civil War service humiliated. Union Maj. Gen. Philip Sheridan relieved Warren of his command for moving too slowly at the 1865 battles of White Oak Road and Five Forks. Warren died just before a court of inquiry found Sheridan's move unjustified.

— COURTESY LIBRARY OF CONGRESS —

George Wheeler. The latter was so taken with the history of mapping that he reprinted Warren's memoir from the 1850s. Warren and Wheeler's reports were a crash course in discovery and exploration through maps, a territorial inventory of American history. Prior to 1850, this awareness of past geographical knowledge as relevant to the nation's future did not exist.

During the Civil War, Warren created battle maps, particularly of the Gettysburg campaign. Initially a lieutenant colonel for the Union, Warren had risen to the rank of major general after his heroic efforts during Gettysburg. As chief engineer, he initiated a last-minute defense of Little Round Top that rescued an undefended left flank of the Union Army from certain attack by Confederates. He came into conflict with Philip Sheridan when the major general humiliated Warren by removing him from command in 1865.

After the war, Warren engaged in civil engineering projects. He fought to clear his name with the military and was exonerated from any wrongdoing in 1882, the year he died, at the age of 52. 

Susan Schulten, professor of history at the University of Denver, is the author of *Mapping the Nation: History and Cartography in Nineteenth-Century America*. This is an edited excerpt from her book.



Secretary of State Jefferson Davis ordered the creation of a map of the U.S. territory from the Mississippi River to the Pacific Ocean (right), which Gouverneur Kemble Warren delivered while he accompanied railroad route explorations in the 1850s. The cartographer found more fame in the Civil War, and he is shown above (fifth from left, in front of the flag) with his Union troops at the 5th Army Corps headquarters in 1864.

-WARREN MAP COURTESY LIBRARY OF CONGRESS; WARREN PHOTO COURTESY HERITAGE AUCTIONS, JUNE 7, 2014 -



5 President Tours Yellowstone

In the fall of 1872, Ferdinand V. Hayden's survey members reached the Snake River, below the mouth of Gros Ventre Creek. President Chester Arthur is shown with his party, crossing the Gros Ventre River in Yellowstone, 11 years later. His extensive overland march, mostly on horseback, marked the first visit by a U.S. President to Yellowstone National Park.

- COURTESY LIBRARY OF CONGRESS -

THE 100 BEST Historical Photos OF THE AMERICAN FRONTIER

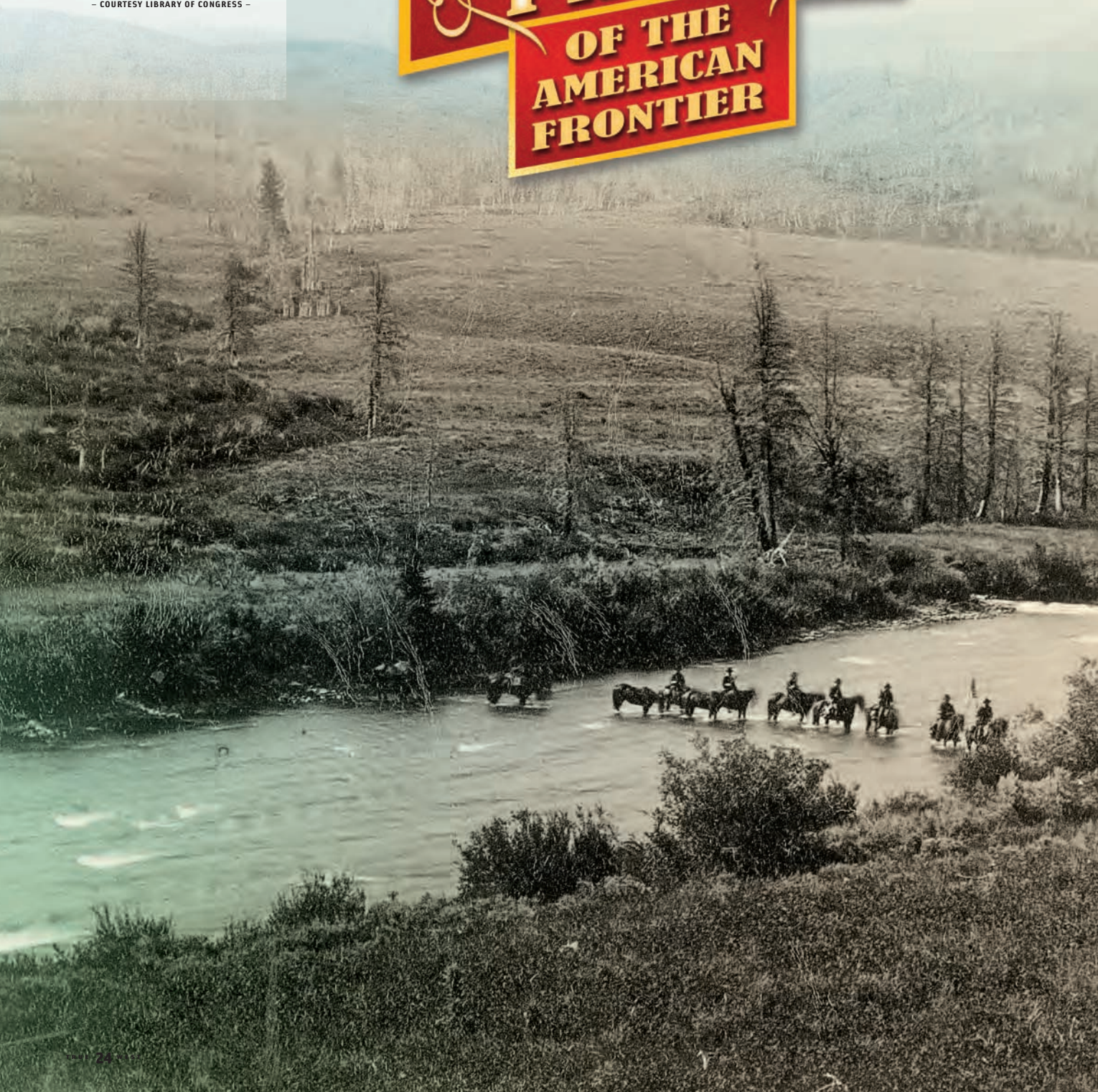

Follow the Yellow Brick Road

Gold paved the path to geological explorations of the frontier West.

In the summer of 1833, Joseph Rutherford Walker found himself guiding yet another expedition into the wilderness West. But this time, his approach to the Sierra Nevada via a Carson River route would become world famous as part of the California Trail, the primary route emigrants traveled to reach the gold fields, after James W. Marshall's nugget discovery in 1848 inspired a gold rush.

California's gold rush encouraged states to explore their own mineral wealth in geological surveys. By 1859, for the first time ever, industrial wealth exceeded the value of agricultural products. Farmers had better chances of making money as miners. Colorado found gold that year, while Nevada's Comstock Lode struck silver.

After California conducted a state geological survey, in the midst of the Civil War, mind you, the federal government saw the war conclude with an increase in demand for national resources. For the first time ever, Congress, 150 years ago, on March 2, 1867, authorized Western explorations that focused on geology.

The Hayden, King, Powell and Wheeler surveys took to the field to conduct what history has dubbed the "Four Great Surveys of the West."

Once Clarence King became the first director of the U.S. Geological Survey in 1879, he remarked how the year 1867 had been "a turning point, when the science ceased to be dragged in the dust of rapid exploration and took a commanding position in the professional work of the country." —*Meghan Saar*





BY KATE RULAND-THORNE

A Man of Many Firsts

Joseph Rutherford Walker blazed trails in the nation's first government surveys.

To describe Joseph Rutherford Walker as a typical frontiersman would be to label Abraham Lincoln a typical president. Walker was a man of many firsts: The first to guide a government survey party assigned to map the Santa Fe Trail; the first to find a navigable route over the Sierra Nevada Mountains to California; the first to lead an emigrant train over that route; the first white man to set eyes on the Yosemite Valley; and the first to discover the gold that initiated Arizona as a territory in 1863.

During his lifetime, Walker was more sought after as a guide than Jedediah Smith, Bill Williams, Joe Meek, Jim Bridger, Ewing Young or Kit Carson. People under the leadership of those guides often lost their lives. Anyone who traveled with Joe Walker survived, a claim no one else could make. Meek once admitted that "to accompany [Walker] on an expedition put a feather in a man's cap." The collective opinion of his fellow frontiersmen agreed: "...[Walker] didn't follow trails, but rather made them."

Walker was born in Roane County, Tennessee, on December 13, 1798. His father fought in the Revolutionary War and was a member of George Washington's famous spy ring. Walker and his six siblings grew up among surveyors, war heroes and special government service agents.

In 1803, when Walker was four years old, President Thomas Jefferson purchased Louisiana Territory from France and sent Meriwether Lewis and William Clark on their famous expedition. This glorious event fired the young Walker's imagination and inspired his lifelong yearning to participate in America's Westward Expansion.

At the age of 15, Walker, some members of his family and his kinsman Sam Houston joined the Tennessee Volunteer Mounted Gunmen, organized by Maj. Gen. Andrew Jackson. They participated in the Battle of Horseshoe Bend on March 27, 1814, a decisive defeat for the Red Sticks, a force of Creek Indians initially organized by the great Shawnee leader Tecumseh.

By January 1815, Jackson and his army of roughly 4,700 soldiers, including his Tennessee militia, had defeated the British following the Battle of New Orleans. These victories added to

Jackson's reputation when he campaigned for President in 1825 and again in 1828, when he finally won by popular vote. Walker and other members of his clan forged a bond with the future president that lasted until Jackson died in 1845.

When Americans entered the highly lucrative fur trade, some of the best, untapped fur-trapping areas were located in the Spanish Southwest. The few trappers who ventured there were imprisoned or executed, and their furs confiscated. After Mexico declared independence from Spain in 1821, William Becknell blazed the Santa Fe Trail, with five others, including Walker. Becknell expedited the sale of his trade goods at an astonishing profit. By early spring 1822, he was on his way back to Santa Fe, in what ultimately became New Mexico Territory, with three full wagonloads and 21 men, including Ewing Young and William Wolfskill.

Luckily for Becknell, Walker had stayed behind to trap beaver. Becknell spent weeks struggling to find a passable route for his wagons through the mountains, until he ran into Walker near the Arkansas River. With Walker's help, he found a wagon route near the Cimarron River. For this discovery, Becknell has gone down in history as the "Father of the Santa Fe Trail," an impossible success without his friend Walker. Years later, Walker's modest comment about the event was, "I helped him [Becknell] break the crust."

For the next few years, Walker and his Mountain Men friends became known as the Taos Trappers. They well understood how attention to the smallest details meant survival. Thirty years after having passed a place in his earlier travels, Walker still remembered where he could find water, game and forage.

In 1825, Walker set off to guide the first U.S. Government survey of the Santa Fe Trail. Upon the guide's return to Fort Osage, Missouri, the governor asked Walker to select a site for a new town. Walker named the new town Independence and agreed to serve as Jackson County's first sheriff. Walker's calm but firm demeanor commanded such respect that not one murder was committed during his two terms in office.

One of his duties as sheriff was to watch out for runaway slaves and indentured servants. A 16-year-old apprentice by the name of Christopher Carson was just such a runaway. Walker took a liking to the lad. Rather than returning Carson to his master, who advertised a one-penny reward for him, Walker put him in the care of his Taos trapper friends. Wolfskill hired Carson to take care of his horses, nicknamed the boy Kit and eventually taught him to become a first-rate

Not one man lost his life
under the leadership of the
frontier trail-blazing guide
Joseph Rutherford Walker,
photographed here, circa
1860, by Mathew Brady.

- TRUE WEST ARCHIVES -

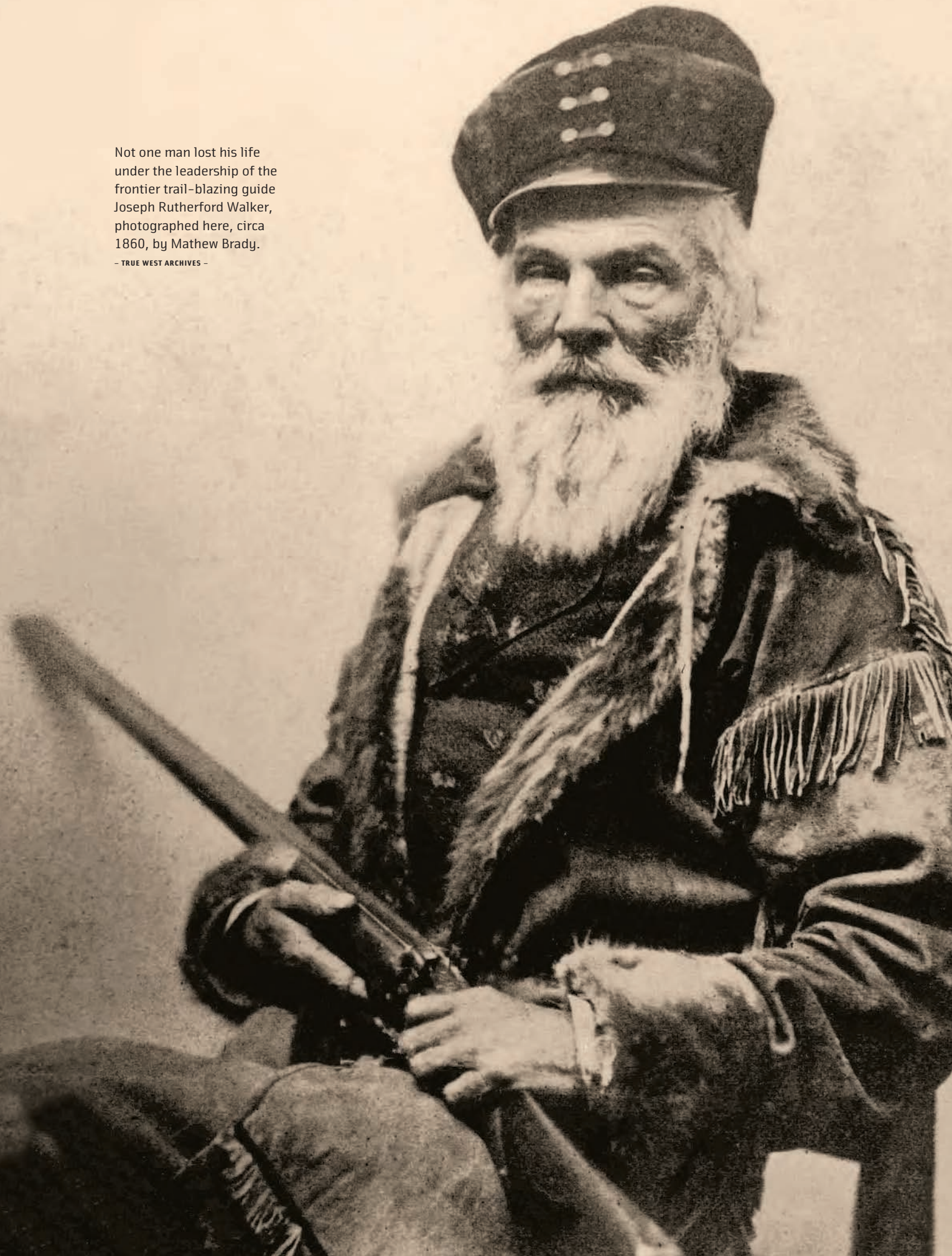



6 Sluicing for Gold

William Henry Jackson captured for posterity these Colorado miners sluicing for gold in Boren's Gulch during the 1875 survey under Ferdinand V. Hayden.

— COURTESY NATIONAL ARCHIVES AND RECORDS ADMINISTRATION —

trapper. Walker, Wolfskill and Carson remained lifelong friends.

In 1830, Walker answered a summons from his cousin Sam Houston to come to Fort Gibson, Oklahoma. There, Houston introduced Walker to Capt. Benjamin Louis Eulalie de Bonneville, who had been assigned by President Jackson to launch a fur trading expedition privately financed by John Jacob Astor. Historians believe that the true purpose of the mission, however, was to locate a navigable route over the Sierra Nevada Mountains to California and assess the strength of the Mexican armies stationed there. Bonneville wanted Walker to guide the venture.

In May 1832, a lavishly outfitted brigade of 110 men left Fort Osage, Missouri, equipped with 20 supply wagons and four horses per man. Walker recruited 40 trappers excited about the venture and anxious to explore the little known Pacific Coast.

For the next two years, Walker's entourage endured incredible hardships, including Indian attacks, near starvation and treacherous descents through the freezing snow of the Sierra Nevada Mountains. In the process, they lost 24 horses, 17 of which provided food for the starving men. But despite their numerous near death experiences, not one of Walker's men lost his life. When the Walker Party emerged from those treacherous mountains, they looked down upon the Yosemite Valley, the first white men to see it.

The Walker party took a different route home by working their way through the San Joaquin Valley. They found a low-

lying pass through the mountains near the Kern River, later named Walker Pass. Walker would guide the first successful wagon train to California over this route in 1833. He would use the southern portion of Walker Pass 10 years later, while leading John C. Frémont's expedition.

Walker reunited with Bonneville in time for the 1835 Mountain Man rendezvous near the Green River in modern-day Wyoming. Two years later, fashion turned to silk hats, and the fur trade died out.

From 1844 to 1846, Walker served as a guide for Frémont's second and third expeditions to California. Frémont was the only man Walker ever disdained. "Morally and physically [he] was the most complete coward I ever knew..." Walker noted.

After America's defeat of the Mexicans in 1848, Walker settled down to ranching in the Monterey area of California and later in Contra Costa County, where most of his family had migrated by the 1850s. He remained in demand as a guide for both government and private expeditions. Walker was 62 years old in 1861, yet retained the energy and vitality of his youth. For 20 years, he had wanted to explore the southern

THE 100 BEST Historical Photos OF THE AMERICAN FRONTIER

region of New Mexico Territory (consisting today of Arizona and the southern tip of Nevada), but the region, considered Terra Incognita, was at the mercy of the fierce Apaches. When friends approached him about leading a prospecting party to look for gold there, Walker didn't hesitate, despite the fact that he was going blind. Of the numerous discoveries and expeditions in which Walker participated, this adventure would stand out as his most memorable...and as his last.

By the spring of 1863, the Walker Party found the gold they had been looking for in north central Arizona. Their discovery would bring about the creation of Arizona Territory and the founding of the city of Prescott.

Walker spent his last years living with his nephew in Ygnacio Valley, California. He died October 27, 1876, at the age of 77, and he was buried in Alhambra Cemetery in

Martinez. His name survives today on Walker Pass, Walker Lake, Walker River, Walker Valley, Walker Gulch, Walker Canyon, Walker Creek, Walker Trail, Walker Peak, Walker Mining District, Walker, Arizona, and Walker, California. ✦

Kate Ruland-Thorne became fascinated with Joseph Rutherford Walker while researching her book, *Gold, Greed & Glory*, sharing the territorial history of Arizona.

7 California Gold Rush Miners

These fortune hunters, photographed by Robert Vance, circa 1850s, traveled on the California Trail blazed by Joseph Rutherford Walker in hopes of striking gold.

- COURTESY HERITAGE AUCTIONS, MAY 21, 2011 -



BY THOMAS P. HUBER

Hayden's Hallowed Expedition

The 150th anniversary of the birth of the American West's four major surveys.

Tracking back 150 years ago, the Hayden Survey had humble beginnings, starting with the unpromising early life of its leader. Ferdinand Vandever Hayden was born into an unstable family and was most likely illegitimate. His father was an alcoholic, and his early years were lived in relative poverty.

He got his first lucky break when his mother sent him to live with relatives in Ohio. Here, he had a supportive aunt and uncle who provided guidance and encouraged his education. He also was introduced to the world of science when he enrolled in nearby Oberlin College in 1845.

An intensely ambitious youth, Hayden was determined to “make something of himself.” During this early period, he began to hone his skills in lobbying and self-promotion—abilities that he learned well. His first major act of self-promotion was to meet John Newberry while he was still at Oberlin. Newberry was a locally prominent scientist whose connections would be the motivating force for Hayden's scientific career.

Newberry introduced Hayden to Dr. James Hall, who was influential in getting Hayden into medical school in Albany, New York, after he had graduated from Oberlin. With few exceptions during the mid-19th century (the Sheffield Scientific School being one), medical school was the only formal science training available.

Hayden graduated from Albany in the spring of 1853, but he never wanted to practice medicine; he wanted to be a geologist and participate in the discovery and exploration of natural phenomena. Hall, a renowned geologist, had an abiding

interest in the West and hired Hayden to conduct fieldwork that summer of 1853 as an assistant to Fielding Bradford Meek,

8 Master of Reconnaissance

Revered as a master of reconnaissance in the Upper Missouri Country, Ferdinand V. Hayden earned respect as the leader behind America's first federally-funded survey into Yellowstone, where this photograph of him was taken. The U.S. government sent out four surveys to explore the American West's geological characteristics and mineral wealth.

— COURTESY USGS —



working in the badlands of the southwestern Dakotas to study the geology and collect thousands of fossil plants and animals. That summer solidified in Hayden's mind what he would do for the remainder of his life. He was starting on his quest to "become somebody."

Hayden spent the next two years in individual field study in the upper Missouri River Basin, including along the upper Yellowstone River. In 1856–57, he joined Gouverneur K. Warren's expedition to Nebraska. This work provided valuable lessons for Hayden—not the least of which was that he bristled under the command of another leader. Hayden made an unconscious vow never to be an assistant again. He wanted scientific autonomy and administrative control of his work.

In the summer of 1859, Hayden worked with Capt. William F. Reynolds in the upper Yellowstone. He spent the next few years in Washington, DC, where he wrote up and published his early work. He was starting to make a scientific name for himself.

In October 1862, Hayden enlisted in the U.S. Army and went to work as a military surgeon. He performed well, but rankled under the supervision of others—a trait that he exhibited during his entire life. He left the Army after Appomattox and was appointed, in 1865, an auxiliary professor of geology at the University of Pennsylvania. The job did not keep him in Philadelphia for long. He arranged his academic schedule to enable him to head west the next field season.

The year 1867 saw the birth of the four major surveys of Western geology and geography, funded by the U.S. government and designed to study different parts of the West and for different ends. The Hayden Survey was the largest, most prolific and well-funded of all four.

Hayden lobbied hard for and received the head geologist position for a survey of the new state of Nebraska. The government allocated \$5,000 for the entire summer's work, and his letter of appointment said he should locate and evaluate "all beds, veins, and other deposits of ores, coals, clays, marls,



9 Finding Peace in Yellowstone

Hayden's lengthy report detailing the Yellowstone region, accompanied by William Henry Jackson's photographs and sketches and paintings by Thomas Moran (photographed here by Jackson in 1871), encouraged Congress to call for the establishment of a national park at the headwaters of the Yellowstone River.

— ALL PHOTOS COURTESY NATIONAL PARK SERVICE UNLESS OTHERWISE NOTED —

and peats" and "[Nebraska's] soil, subsoils and [provide a] description of their adaptability to particular crops, and the best methods of preserving and increasing their fertility."

This was a tall order, especially because he could not get started until June 18—a waste of nearly two months of field time. These funding delays proved a constant irritant to all of the surveys every year. Congress often did not complete appropriations until May, leaving each survey wondering when or if members could start their work for that season.

Hayden spent most of the 1867 and 1868 field seasons in Nebraska, with some time in Wyoming and brief forays into Colorado. He went on a whirlwind geologic reconnaissance of Colorado in 1869. His written description of this trip, in the Annual Report for 1867–69, reads like a travelogue from an arm-waving geologist talking from a fast-moving train through the landscape. His brief trek through Colorado, however, set the stage for the much more rigorous and organized survey of the territory prior to Colorado becoming a state on August 1, 1876.

Much of the intervening time between Hayden's first tentative work in Colorado and the start of his major work there in 1873 was spent in Wyoming, especially surveying the greater Yellowstone ecosystem, including the Grand Tetons and the future Yellowstone National Park. Hayden did not "discover" Yellowstone and its environs, but his survey's work there made a huge impression back East. His 1871 field season results went far in promoting Yellowstone as the site for the first national park in U.S. history. By March 1, 1872, Congress had passed the Yellowstone Park Act, and Hayden was readying for his second field season there.

After the stunning successes of his Wyoming expeditions, after the majestic paintings of the Grand Canyon of the Yellowstone River by survey artist Thomas Moran, after the designation of Yellowstone as a national park, Hayden abruptly changed locales. He decided that Colorado was the next best

Leaders of the Great Geological Surveys of the West



10 Ferdinand V. Hayden (Survey: 1867-79)



Clarence King
(Survey: 1867-78)



11 John Wesley Powell (Survey: 1869-79), standing next to Taugu, a Paiute chief



12 George M. Wheeler (Survey: 1869-79), wearing black hat, seated in center

place to concentrate his efforts. He wrote: "The prospect of [Colorado's] rapid development within the next five years, by some of the most important railroads of the West, renders it very desirable that its resources be made known to the world at as early a date as possible."

This long-term, meticulous survey went down in history as the only one of a single state or territory explored in such depth. The scientific research done here made Colorado the most intensively studied place in the entire West, with the possible exception of California. The Atlas of Colorado that Hayden's survey produced lifted up Colorado as the envy of every other state or territory and many foreign governments.

Although the Colorado atlas was not published until 1877, maps from Hayden's tour de force of geographical efforts made their way to our nation's first world's fair, the 1876 Centennial Exposition in Philadelphia. His survey offered much more than a geological or geographical description of Colorado and the West. Hayden and his scientists and topographers looked at the land in all its varied facets. They described water resources, energy potential, agricultural promise, tourism attraction and esoteric natural history phenomena. They mapped the land and gave shape to many a dream. ★

Thomas P. Huber is a professor of geography and environmental studies at the University of Colorado at Colorado Springs. This is an edited excerpt from *Hayden's Landscapes Revisited: The Drawings of the Great Colorado Survey* written by Huber and published by University Press of Colorado in 2016.



Located in today's Gunnison National Forest, Italian Mountain was among the sketches by William Henry Holmes of Hayden's survey in Colorado Territory.

- PUBLISHED IN HAYDEN'S ANNUAL REPORT FOR 1873 FIELD SEASON -



13 Dwarfed by Garden of the Gods

This William Henry Jackson photograph of horseback members of the Hayden Survey at Cathedral Spires may be the first photograph ever taken of the Garden of the Gods in Colorado Territory.

- COURTESY USGS -

14 Climbing Jupiter Terrace

William Henry Jackson photographed artist Thomas Moran climbing the terraces of Mammoth Hot Springs (below), an experience that inspired

his sketch of figures exploring Jupiter Terrace (inset).

- JACKSON PHOTO COURTESY BUFFALO BILL CENTER OF THE WEST ON LOAN FROM DR. ROBERT ENTEEN; MORAN SKETCH TRUE WEST ARCHIVES -



THE **100** BEST
Historical
Photos
OF THE
AMERICAN
FRONTIER

17 Iconic Cameraman

When Ferdinand V. Hayden discovered William Henry Jackson's photographs for the Union Pacific, he asked Jackson to join his geological survey to explore the Yellowstone River region. Starting with the 1871 survey, Jackson traveled to breathtaking sites, including Glacier Point in Yosemite, captured in this iconic photograph of Jackson with his camera (opposite page).

- TRUE WEST ARCHIVES -



15 Measuring Distance

The Hayden Survey used this mule-drawn odometer, photographed by William Henry Jackson in 1871, to get approximate distances over long traverses. For the 1873 exploration of Colorado, Hayden divided the territory into northern, middle and southern regions, and assigned an expedition party to survey each area.

- COURTESY USGS -



16 Mesmerized by Ancient Ruins

One of the first photographs of Colorado's Mesa Verde ruins show Capt. John Moss and Ernest Ingersoll in the Canyon of the Mancos, photographed by William Henry Jackson in 1874 for the Hayden Survey.

- COURTESY LIBRARY OF CONGRESS -



THE **100** BEST
Historical
Photos
OF THE
AMERICAN
FRONTIER

Mountain Men with Cameras

Many of the most exceptional and awe-inspiring views of the American West came from pioneer photographers of all sorts—whether they were documenting official government expeditions, akin to Ferdinand V. Hayden's, or photographing privately-funded explorations, like some of John C. Frémont's. Some set off on their own, these brave adventurers, equipped with their image-making tools and a fervent desire to capture, for generations to come, the dangerously wild and largely unseen frontier explored by them firsthand. Just like the Mountain Men proved instrumental in opening up emigrant trails to the far west, all of these pioneer photographers blazed trails with their cameras to bring this Great Frontier to life.

—*Meghan Saar*



18 **Earliest Known Image of an Indian Camp**

Solomon Nunes Carvalho made this daguerreotype of a Plains Indian village in present-day Colorado in 1853, during John C. Frémont's fifth expedition. After passing through the Rocky Mountains and Sierra Nevada Mountains, Frémont believed a railroad line along the 38th Parallel was feasible.

— COURTESY LIBRARY OF CONGRESS —

**THE 100 BEST
Historical
Photos
OF THE
AMERICAN
FRONTIER**

19 Early California Gold Rush View

Charles Leander Weed was a New Yorker who trekked to the gold fields in California, most likely on the trail blazed by Joseph Rutherford Walker, and became a camera operator at George J. Watson's studio in Sacramento. He took this photograph of Forest Hill, along the gold-bearing American River, around 1858.

— TRUE WEST ARCHIVES —



21 Inspired by Hayden's Cripple Creek

Before the gold discovery in 1890, the "only publication concerning the geology of the Cripple Creek area" was the 1873 survey by Ferdinand V. Hayden, wrote Whitman Cross, adding how the volcanic area south of Pikes Peak referenced in the report was likely Cripple Creek. While mapping the Pikes Peak district in the summer of 1893 for the U.S. Geological Survey, Cross and his team spent about 10 days in the Cripple Creek region. This 1893 photo of a geological party on its way to map the Cripple Creek mining district is probably of them. The next year, Cross extensively surveyed Cripple Creek.

— COURTESY NATIONAL ARCHIVES AND RECORDS ADMINISTRATION —

22 Man on the Ledge

Originally hired as a boatman for John Wesley Powell's second expedition down the Colorado River, from 1871-1872, John K. Hillers ended up assisting expedition photographer James Fennemore. Hillers sits in the ledge of this photo of the Grand Canyon, taken in April 1872.

— COURTESY LIBRARY OF CONGRESS —



20 Dangling in Yosemite

Sitting precariously on the edge of Contemplation Rock, at Yosemite's Glacier Point in 1872, Eadweard Muybridge overlooks one of the greatest views in the world.

— COURTESY COLLECTION OF CALIFORNIA HISTORICAL SOCIETY —

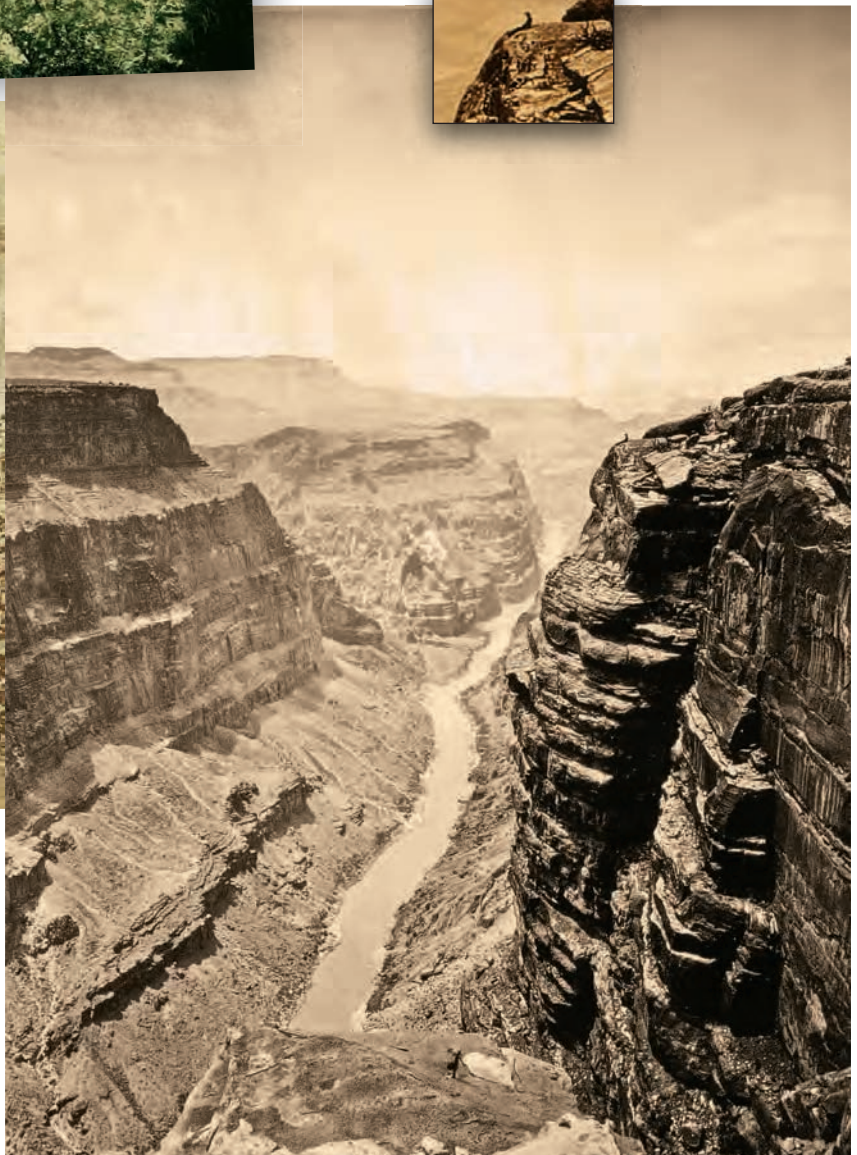



**THE 100 BEST
Historical
Photos
OF THE
AMERICAN
FRONTIER**

23 Sketching the Ruins

In 1873, during George Wheeler's government-funded expedition, artist Alexander Helwig Wyant sketched the ruins of Cañon de Chelly in Arizona Territory, which photographer Timothy H. O'Sullivan captured for generations to witness. After he suffered a stroke during the survey that paralyzed his right arm, Wyant switched to painting with his left hand, which gave his later artworks an abstract look.

- COURTESY LIBRARY OF CONGRESS -

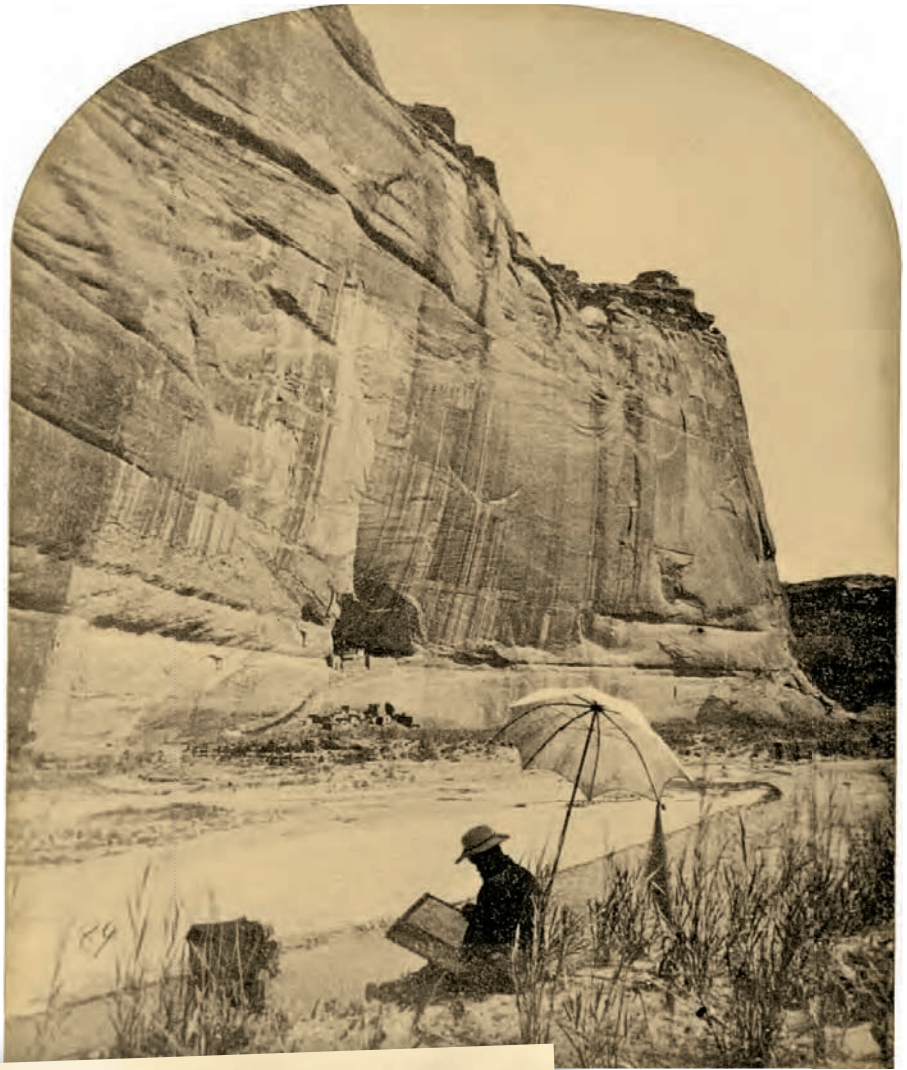

24 Boats for the Colorado

During Robert Brewster Stanton's survey of the Colorado River, 1889-1890, on behalf of the Denver, Colorado Canyon and Pacific Railroad, this glorious photograph was taken of an overland caravan laden with boats.

- COURTESY NATIONAL ARCHIVES AND RECORDS ADMINISTRATION -

25 Relaxing on the Green

Powell Survey ethnologist James C. Pilling smokes his pipe along Colorado's Green River, at the Gate of Lodore, in this 1874 photograph by John K. Hillers.

- COURTESY LIBRARY OF CONGRESS -

26 Married to the Mountains

Photographed by John K. Hillers, this rare 1874 view of a Uinta Ute warrior and his bride showcases the couple in their valley homeland, along the western slope of the Wasatch Mountains, in Utah Territory.

- COURTESY LIBRARY OF CONGRESS -

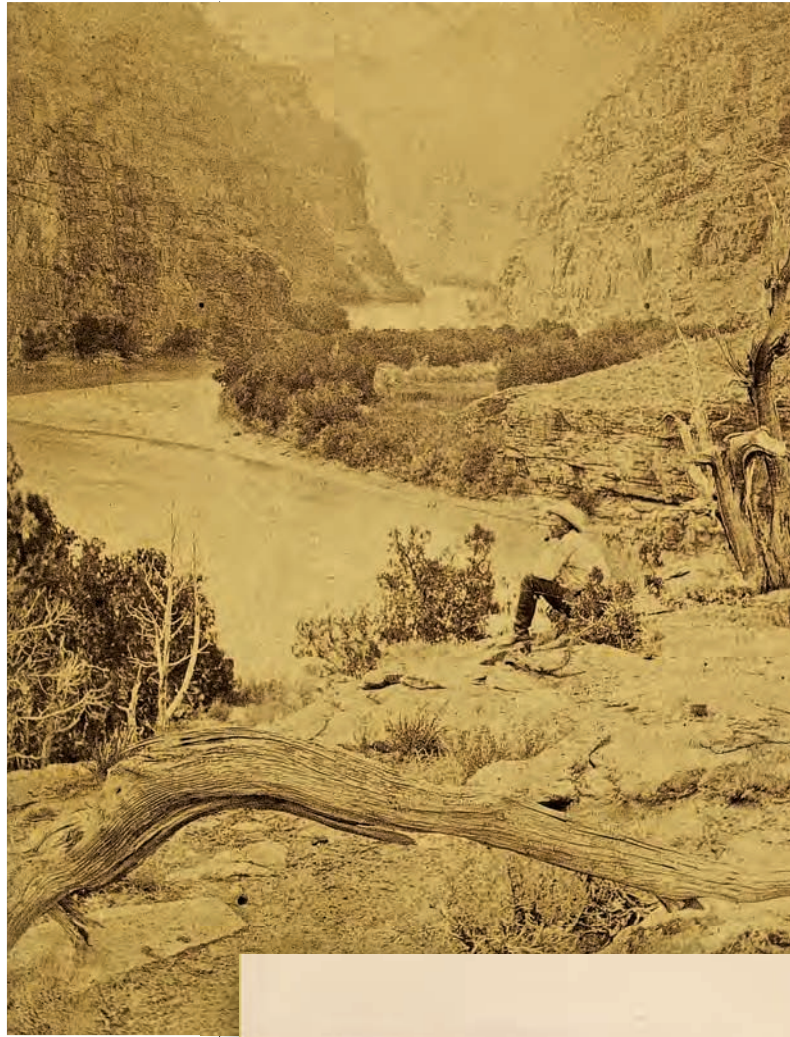

28 Farming Along Lake Mona

In 1872, during the Wheeler Expedition, William Bell captured this view of civilization in Utah Territory, an artificial lake for irrigation, Lake Mona.

- COURTESY LIBRARY OF CONGRESS -

27 Earthquake Camp

After the Hayden Survey members felt shocks of earthquake at this site near Steamboat Point, on the east side of Yellowstone Lake, on the night of August 19, 1871, William Henry Jackson took this photograph of their "Earthquake camp."

- COURTESY YELLOWSTONE NATIONAL PARK -

**THE 100 BEST
Historical
Photos
OF THE
AMERICAN
FRONTIER**



**29 In the
Mariposa Grove**

Galen Clark and Milton Mann discovered the Mariposa Grove, which they named after Mariposa County, California, in 1857. Sometime in the 1860s, Carleton E. Watkins captured this view of folks posing inside one of the giant sequoias. These may be survey members exploring Yosemite for the California Geological Survey.

– COURTESY LIBRARY OF CONGRESS –



**31 Darkroom in a
Great Frontier**

During the Hayden Survey, William Henry Jackson developed his photographs of the great frontier in a darkroom tent, which he stands next to in this image. You can see by the tent's small size why he had to crawl in on his hands and knees to process his glass negatives.

– TRUE WEST ARCHIVES –

30 Where Gold Turned into Silver

Nevada's gold-rich town that ushered in the first major silver discovery in the U.S., the Comstock Lode, Gold Hill was preserved in its 1867 state by Timothy H. O'Sullivan, during Clarence King's geological exploration of the 40th Parallel. The photographer's portable developing box appears in the lower left corner of this view overlooking this historic town that can still be accessed by train from its more famous neighbor, Virginia City.

– COURTESY LIBRARY OF CONGRESS –



**32 Washakie
Badlands**

In 1872, the last year of the King Survey organized by the War Department, photographer Timothy H. O'Sullivan turned the camera upon himself in this view of him (opposite page) seated in the Washakie Badlands of Wyoming Territory, just north of the Colorado border.

– COURTESY LIBRARY OF CONGRESS –



THE 100 BEST Historical Photos OF THE AMERICAN FRONTIER

35 First Picture of Old Faithful in Action?

William Henry Jackson's majestic photographs taken during the Hayden Survey helped convince a nation to make Yellowstone its first national park. His iconic role in history may explain why people like to believe that this 1872 photograph of his (opposite page) is the first picture of Old Faithful in eruption. It's not. Thomas Hine, a photographer who was part of an independent military reconnaissance party organized by Lt. Gen. Philip Sheridan, photographed it first, the year before. In all fairness, Hine's "Fire Hole Basin" view is free of people, unlike Jackson's breathtaking image of Old Faithful shooting boiling water roughly 150 feet into the air.

- COURTESY YELLOWSTONE NATIONAL PARK -

33 Camp Along the Colorado

George Montague Wheeler led his first expedition of the frontier West from 1869-1871. Photographer Timothy H. O'Sullivan framed this 1871 view of the Colorado River against the backdrop of the survey camp.

- COURTESY LIBRARY OF CONGRESS -

34 Distant Early View of Apache Fort

In a later Wheeler geological survey, exploring west of the 100th Meridian, Timothy H. O'Sullivan photographed Camp Apache, in 1873 Arizona Territory, two years after the site became an Apache reservation. The Apaches who lived here were forcibly marched to their new home on the San Carlos reservation by 1875.

- COURTESY LIBRARY OF CONGRESS -





TRUEWEST
HISTORY OF THE AMERICAN FRONTIER

BEST *of the* WEST

TWO THOUSAND SEVENTEEN



Our 15th Annual Celebration of the Absolute Best of the West!

Congratulations to our 2017 Best of the West winners! Our pictorial voyage celebrates the best earliest-known photographs of the American West frontier, along with a collectors' roundup of rare Yellowstone expedition albertypes and last year's best Old West-themed books, movies, firearms and Western wear. Pioneer paths of history inspired the back roads and highways that today lead you to experience the frontier in all the places featured in our Best of the West Heritage Travel Guide. Everyone honored this year has played an important role in keeping our Old West history alive, and we thank you for supporting each one's efforts. Enjoy your exploration of the best the West has to offer you!

36 Darkroom in the Desert

Tracking across the shifting sand dunes near Nevada's Carson Sink in 1867, Timothy H. O'Sullivan's darkroom wagon dramatizes the pioneering experience of exploration in the West's uncharted landscapes.

— TRUE WEST ARCHIVES —



ART AND COLLECTIBLES

BY MEGHAN SAAR

Almost Burned: Jackson's Rare Yellowstone Albertypes

In the early stages of his career, William Henry Jackson, his studio borne by a mule, photographed the first views of Yellowstone. He traveled as an expedition member for Ferdinand V. Hayden's U.S. Geological Survey in 1871 to investigate the marvels that would eventually be preserved as America's first national park—Yellowstone.

Discovered by photograph collector and San Francisco Bay resident Robert Enteen in the summer of 2015, the only complete copy of Jackson's album from that expedition was showcased in an impressive exhibit at the Buffalo Bill Center of the West in Cody, Wyoming, in 2016. That was followed by the auction of the album, which did not meet its reserve price, at PBA Galleries in San Francisco, California, in October.

The bound volume, produced in 1874, was made from Jackson's glass plate negatives using the albertype process, a screenless, photomechanical reproduction technique developed by the Germans. This was a vast improvement from how photos were reproduced for magazines and books—copying the image to a woodcut, which diminished the original photo into a replica.

Edward Bierstadt, brother of noted artist Albert, was under contract by Hayden to produce these albertype albums of Jackson's



37, 38 Thomas Moran

Thomas Moran, the artist whose illustrations joined William Henry Jackson's photographs in bringing the wonders of Yellowstone to the world, is featured in the album. These two images are not among the 13 rare photos.

photographs. He created the proof albums, but got no further. A disastrous fire in his studio in early 1875 destroyed most of the albertypes he had printed as well as virtually all of the original glass negatives. Worst of all? This was not his first studio fire—a gas explosion occurred four years earlier. Perhaps Hayden should have investigated more the man whom he had entrusted with such an irreplaceable treasure.

Fortunately for historians, five sets of the Jackson albertypes survived the 1875 fire, yet the set discovered by Enteen contains the most unique images—76. Outside of two smaller sets, the next largest sets are at the Denver Public Library, with about 30 images, and at the Clark Art Museum in Williamstown, Massachusetts, with 56 prints.

When Enteen found his rare treasure, he worked to document the album with the help of scholars at the Buffalo Bill Center of the West and particularly Dr. Matthew Hermes, a national authority on Yellowstone history who shared the finding in the museum's *Points West* journal. "The Jackson albertypes, had they been used as originally intended, would have been the first effort to promote Yellowstone by photographs," Hermes states. "We like to think they would have been broadly popular, the first 'coffee table' book perhaps."

Showcased on the following pages are the 13 rare Jackson albertypes of his foray into Yellowstone not found among the other sets.



39 The USGS En Route

William Henry Jackson set up this monumental shot of the Hayden Expedition, all mounted, standing beside a lake shore that the USGS identified as Mirror Lake, at the head of Pelican Creek. Expedition leader F.V. Hayden rides second from the right.

— ALL WILLIAM HENRY JACKSON PHOTOGRAPHS COURTESY PBA GALLERIES, OCTOBER 20, 2016 —



40 Tower of Rock

The only vertical shot among the rare William Henry Jackson albertypes never seen before, this offers a view of a tower of breccia volcanic rock near the brink of Tower Falls on Tower Creek.

41 First Yellowstone Bridge

John Baronett built this first bridge over the Yellowstone River, near the confluence of the Lamar River with the Yellowstone.



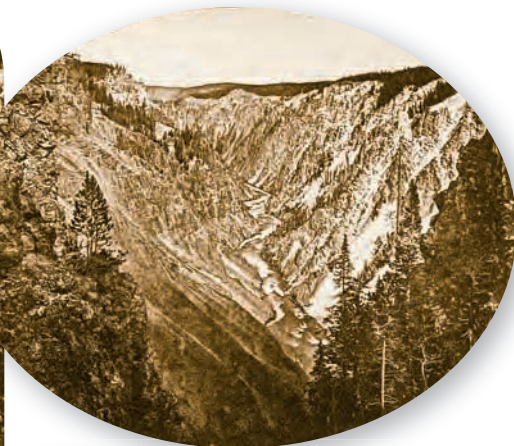

42, 43, 44 Grand Cañon of the Yellowstone

Above is a late afternoon view of the Grand Cañon of the Yellowstone, while one with oval masking, also seen from the brink of the Lower Falls, is shown top right. A different view, printed backwards in the album of albertypes, is shown bottom right.

BEST WESTERN ART COLLECTION

Stark Museum of Art, Orange, TX

Surrounded by the piney woods of southeast Texas is a museum housing an astoundingly impressive Western art collection, started in the 1890s by Miriam Lutchter Stark. She passed the art collecting bug on to her son, H.J., and his wife, Nelda. Neither mother nor son lived to see the opening of their art museum, in 1978, but they accomplished their goal of enriching the quality of life in southeast Texas through the arts. H.J. and Nelda's *Racers at the Pueblo* oil by Oscar Edmund Berninghaus is just one of the major works by the Taos Society of Artists featured at the museum. Explorer-artists George Catlin, Alfred Jacob Miller, John Mix Stanley, Thomas Moran and Albert Bierstadt carry a strong presence at the museum. The story of the American West, expressed so vividly and accurately in art by the West's best pioneer artists, is splashed across these walls.

READERS' CHOICE:

Panhandle-Plains Historical Museum, Canyon, TX

BEST AMERICAN INDIAN COLLECTION

Plains Indian Museum, Cody, WY

You could spend days, if not weeks, exploring the amazing Old West collections at the Buffalo Bill Center of the West. But if you have only one day, anyone who desires to learn the story of the Plains Indians peoples will discover, in this museum, why these historic nomadic tribes have become such an archetype in literature and art. You never know what you might see: Sitting Bull's trade items; Red Cloud's shirt; clothing worn by a Lakota performer during Buffalo Bill's Wild West shows. The most impressive Plains Indian artifacts are those collected by Paul Dyck, dating to the late 1700s to pre-1890s, a period Dyck identified as the "Buffalo Culture" era. In his final months in 2006, the Arizona collector gave the public a great gift by granting the center as the best place to preserve this largest private collection of Plains Indian art and artifacts.

READERS' CHOICE:

Smoki Museum, Prescott, AZ

BEST PIONEER HISTORY COLLECTION

Boot Hill Museum, Dodge City, KS

How incredible that a cemetery site created for a rotary convention in 1932 would lead to a world-class pioneer history collection, showcased in replica buildings of the Front Street originals destroyed by fire in 1885. The pioneer Beeson family collected most of the artifacts, which give visitors insight into early-day families and the lives they lived on the Kansas frontier. When you step into the museum's Long Branch Saloon, you're stepping into Beeson history—one of the owners was Chalk Beeson, before he sold his share to the notorious Luke Short.

READERS' CHOICE:

Harold Warp Pioneer Village, Minden, NE

BEST OLD WEST COLLECTIBLES AUCTION

Heritage Auctions, Dallas, TX

The world's largest collectibles auctioneer marked a milestone in 2016—more than one million online bidders. Heritage Auctions was one of the earliest to embrace mobile

ART AND COLLECTIBLES

technology, and its free database of more than four million prices realized have attracted collectors from all over the world. Among other history offerings, the auction house regularly holds its prestigious “Legends of the West” auction. Its 2016 sale featured historical Tombstone collectibles purchased by another of this year’s winners, Jim Melikian. Every year is somehow better than the last; we continue to be impressed by the incredible Old West finds Heritage Auctions brings to collectors.

READERS’ CHOICE:
*Brian Lebel’s Old West Auction,
Fort Worth, TX*

BEST OLD WEST ART AUCTION

Christie’s, New York, NY

The auction house that has broken record sales for many of our most esteemed Old West artists, Christie’s celebrated its 250th anniversary in 2016. James Christie held his first sale across the pond, in London, in 1766. Not until 1970, though, did Christie’s hold its first sale in the United States, in Houston, Texas. Seven years later, the New York City salesroom opened. The American Art Department has since set more than 100 world records at auction, with one of its most outstanding for the master Old West artist Thomas Moran, when the hammer fell on *Green River of Wyoming* at \$15.85

million. Christie’s New York holds the auction records for both Thomas Moran, William Henry Jackson’s artist counterpart on the Hayden survey, and Albert Bierstadt, brother of Edward whose proof album of Jackson’s images went up for auction in 2016. A collector purchased Bierstadt’s 1862 oil, *Indians Spear Fishing* (top right), for a \$6.53 million bid, while Moran took the gold with a \$15.85 million bid for his 1878 oil, *Green River of Wyoming* (right).

— COURTESY CHRISTIE’S NEW YORK, MAY 21, 2008 —

million. Christie’s is one home in the East where you can still find some of the greatest wonders of the West.

READERS’ CHOICE:
Coeur d’Alene Art Auction, Reno, NV

BEST WESTERN COLLECTIBLES GALLERY

Cowboy Legacy, Scottsdale, AZ

Downtown Scottsdale is that gem in the desert where cowboys go to play, and the best respite from the ranch is Bill Welch’s gallery on Main Street. You may think you have wandered into Scottsdale’s Museum of the West, right around the corner, for all the museum-quality artifacts of the 1840s through the 1940s that hang on these walls, but this shopper’s haven offers all the Old West essence that can transform your home into a frontier history lover’s dream dwelling.

Since 1966, Welch has been offering his expertise on high-end chaps and spurs, collectible saddles, bows and arrows, so browsing here under his helpful tutelage is not only fun, but also quite educational.

BEST OLD WEST FIREARMS AUCTION

*Rock Island Auction Company,
Rock Island, IL*

The most expensive single firearm ever sold at auction hammered down for \$1.1 million at Rock Island Auction Company’s spring sale last May. After Capt. Henry Lawton helped convince Apache leader Geronimo to surrender for good, a friend of Lawton’s, who worked for Winchester Repeating Arms, gave Lawton the Model 1886 Winchester rifle that sold at the auction. Rock Island’s auctions sell historical



ART AND COLLECTIBLES

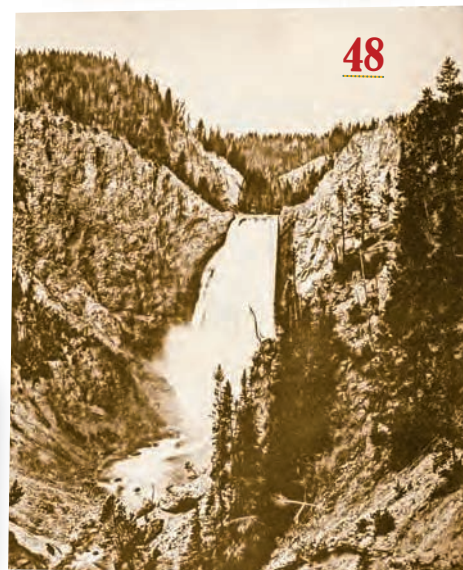

#45: The Upper Falls of Yellowstone. #46: Virginia City, Montana. #47: Rapids Above the Falls of Yellowstone. #48: Lower Falls of Yellowstone, Below Lookout Point. #49: Column Rocks, Looking North from Tower Creek. #50: Yellowstone Lake.

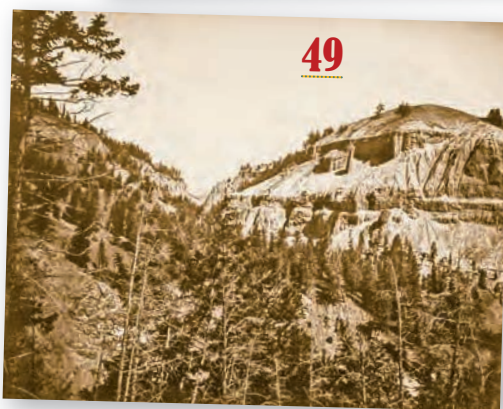

firearms at prices that range from affordable to record-breaking, allowing the everyman and the rich man ample opportunities to purchase guns linked to the Old West era.

READERS' CHOICE:
A&S Auction Company, Waco, TX

BEST TREASURE HUNTING DEVICE

AT Pro Metal Detector by Garrett Metal Detectors, Garland, TX

While diving off the Key West coast of Florida in 2008, Mike DeMar thought his metal detector had hit on a beer can; nope, nearly a pound of gold from the *Santa Margarita* ship that had sunk in 1622. Value: About \$1 million. We all have dreams of finding fortune beneath our feet, but without the proper tool, we may just kick away that millionaire-making “beer can.” Whether you’re in the desert sands or in a shallow stream, hunt for treasure with the all-terrain AT Pro detector, made by the worldwide leader in metal detection technology.

READERS' CHOICE:
TreasurePro by White's Electronics, Sweet Home, OR



BEST WESTERN PAINTER

Sherry Blanchard Stuart, Scottsdale, AZ

Sherry Blanchard Stuart’s first word was “hoy-hoy,” which meant “horse.” She started drawing the majestic creatures long before she ever saw one in person. Although an avid horsewoman, she found the West in her artwork rather late in life, when she moved to Arizona in her 40s. She was living in a vast, empty, beautiful country—cowboy country—and on her first cattle drive, she found her calling to chronicle cowboy life. Whether she’s painting a 5th Cavalry soldier or a mountain man trading beads with Indians, the traditions of the West live again in her nostalgic portrayals of the landscape and people.

READERS' CHOICE:
Andy Thomas, Carthage, MO

BEST WESTERN MUSEUM

Western Spirit: Scottsdale's Museum of the West, Scottsdale, AZ

After an impressive grand opening in 2015, the best museum of the West in the “West’s Most Western Town” showed no



ESTATE AUCTION

SATURDAY, JANUARY 14TH, 2017

BURLEY AUCTION GALLERY

134 Deborah Dr, New Braunfels, Texas 78130

Texas Ranger Collection, Guns & Badges from Texas Ranger Captain & U.S. Marshal Clint Peoples, Jack Dean, John Hughes, & more.

Engraved Colts & Antique Winchesters, Old West Relics, Country Store Advertising & more. 15% BP TX #15184. 830-629-9280.

BURLEYAUCTION.COM



BURLEY
AUCTION GALLERY



UNTAME YOUR ADVENTUROUS SPIRIT

Discover the home of Buffalo Bill and the Golden Spike Tower overlooking Bailey Yard – the world’s largest rail yard. Enjoy outdoor festivals, arts & culture, and fun for all ages. We invite you to come explore western heritage and enjoy fine hospitality in the place where east meets west.



North Platte
NEBRASKA

North Platte/Lincoln County Visitors Bureau
VisitNorthPlatte.com • 1.800.955.4528



"Worried About The Back Trail"
Gouache, 12" X 10" art print
\$45 plus S&H

**CHECK OUT BBB'S
NEW WEBSITE WHERE
HE POSTS HIS
DAILY WHIPOUTS.**

BOBBOZEBELL.NET



51 Devil's Slide

William Henry Jackson captured one of the surveyors sitting on a rock in front of the Devil's Slide formation on the side of Cinnabar Mountain.

sign of slowing down in 2016. For nearly two years, art lovers got to travel with Lewis & Clark through Charles Fritz's impressive paintings. Paintings, etchings and books gave insight into cowboy artist Will James. Saddles and spurs glistened in the A.P. Hays Gallery. The stories of friendship and conflict between mountain men, American Indians, settlers and soldiers emerged in a collection of contemporary art. A retrospective of John Coleman's art opened in the fall. And the new year will bring us artwork by the Taos Society of Artists. Western spirit? This museum's got it.

READERS' CHOICE:
Buffalo Bill Center of the West,
Cody, WY

BEST WESTERN ART GALLERY

C.M. Russell Museum,
Great Falls, MT

The C.M. Russell Museum is more than just an impressive home to the collection of the world-famous cowboy artist—the museum has preserved Charles M. Russell's real home, a two-story frame house, along with his log cabin studio. You can span the

artist's lifespan through the works that grace the museum's walls and then immerse yourself in the place where he created all of it. The C.M. Russell Museum truly is a one-stop homage to the self-taught artist trademarked by his iconic buffalo skull. People love this museum so much that, in 2002, an anonymous bidder at the museum's annual benefit auction paid \$240,000 for Russell's *Waiting* watercolor and then donated it to the museum. How many folks will buy a painting to keep a museum going and then donate that painting to the museum? Apparently, more than one. The trend continued as recent as 2012 with the donation of the Russell watercolor, *The Bucker*. Russell devotees already know this place is the best. The rest of the world should too.

READERS' CHOICE:
Whitney Western Art Museum,
Cody, WY

BEST WESTERN ART COLLECTOR

Tim Peterson

To say that Minnesotan Tim Peterson idolizes explorers Meriwether Lewis and William Clark is no small point. Art lovers

ART AND COLLECTIBLES

got the good fortune of seeing his collection of Charles Fritz's masterful portrayal of the Corps of Discovery's 1805-06 transcontinental journey, in a fabulous exhibit at Western Spirit: Scottsdale's Museum of the West. Peterson's collection of art portraying Mountain Men and fur traders elevated the museum into a world-class art haven. He grew up hunting, fishing and canoeing with his dad, who took him, at the age of eight, to an art gallery, where he purchased his first piece of art: Paul Calle's *Something for the Pot*. This print of a mountain man, carrying his hunt of the day, kindled his passion for the frontier West.

BEST WESTERN HISTORY COLLECTOR

Jim Melikian

Arizona businessman Jim Melikian has been a collector most of his 61 years, but the Old West finally caught his fancy in the summer of 2016. When he opened Heritage Auctions' catalog, "Legends of the West: The Tombstone and Arizona Territory Collection," he thought, "This is cool, but is it rare?" He turned to experts to find out, including *True West's* Bob Boze Bell and Arizona historian Jack August. Rare? Unbelievable, they told him, noting it was unprecedented to have nearly 190 lots from 1870s-80s Tombstone come up for auction at one time. Melikian bought the bulk of the collection, some of which went on display at the Arizona State Capitol. He can't decide on his favorite. Is it the bank draft cashed the day of the shoot-out behind the O.K. Corral, or is it the petition—signed by Tombstone founder Ed Schieffelin—nominating John Brannick for Tombstone constable? Or it could be...well, he has a lot to chose from. ★

Meghan Saar is the editor of *True West* and writes the magazine's *Collecting the West* column. Her first auction report appeared in the November/December 2003 issue.



SHERRY BLANCHARD STUART

"Booshway"

36 x 24 Oil on linen

Exhibiting in the 12th Annual
Cowgirl Up!

Art from the Other Half of the west

March 24 - May 7, 2017

Desert Caballeros Western Museum
Wickenburg, Arizona 85390
928-684-2272

www.westernmuseum.org
www.sherryblanchardstuart.com

WESTERN BOOKS

BY STUART ROSEBROOK

The Past is Present

When historians review the year 2016 in publishing, will they discover themes in Western history and fiction that reflected the national turmoil and tumultuous political year that preceded the quadrennial contest for the White House? I would argue that today's authors have not—and cannot—divest themselves from the present. I believe that the best publications of novelists and historians in 2016 were consciously and subconsciously influenced by our troubled era of instantaneous information.

As futurist Alvin Toffler, who died June 27, 2016, prophesied in his 1970 masterpiece *Future Shock*: “In our lifetime the boundaries have burst. Today the network of social ties is so tightly woven that the consequences of contemporary events radiate instantaneously around the world...”

“Indeed, not only do contemporary events radiate instantaneously—now we can be said to be feeling the impact of all past events in a new way. For the past is doubling back on us. We are caught in what might be called a ‘time skip.’”

Toffler was correct in writing that “the past is doubling back on us.” Paul Andrew Hutton’s *The Apache Wars: The Hunt for Geronimo, the Apache Kid, and the Captive Boy Who Started the Longest War in American History*

is *True West*’s best book of the year, but Hutton is also *True West*’s best author of 2016. The University of New Mexico professor carries the Guidon for an extremely strong set of biographies and historical syntheses of

Apache Wars is not politically provocative, nor does it proselytize his conclusions the wars were catalysts of political or social change. Instead, Hutton allows the facts of the Apache-American-Mexican border war

to tell the story of one of the most chronicled American wars—yet, I believe, one of the least understood international wars. This war was fought with such brutality and heinous civilian and battlefield atrocities that 130 years after Geronimo’s surrender in August 1886, the modern border issues between Mexico and the United States have double-backed on both nations in what we might truly call a “time skip.” With succinctness and clarity, Hutton leaves the reader of *The Apache Wars* with a

sense of ancient déjà vu. One feels that the tragedy of the Mexican-Apache-American war is not just an anecdotal conflict unique to North American history, but that in the world today it continues to manifest on a deadly, daily basis in a perverse ingemination of human behavior.

Amidst the gravitas of the past year’s prose, two publishing trends of 2016 non-fiction also must be noted: “Law and Order” and American Indian History dominated the catalogues, and are reflected in separate Best of the Year categories. In Old West and modern Western fiction, novelists have continued to mine the themes of Joseph Campbell’s “hero’s journey” for inspiration, and channel William



Apache Camp

Arizona Territorial photographer C.S. Fly accompanied Gen. George Crook when he negotiated Geronimo’s next-to-last surrender in March 1886. Fly’s photo of a group of Chiricahua adults and children included a kidnapped white boy named Jimmy “Santiago” McKinn. The irony of McKinn’s rescue is that the 1861 kidnapping of young Felix Ward, aka Mickey Free, led to the Bascom Affair, and the 25-year war with the Chiricahua.

— COURTESY LIBRARY OF CONGRESS —

our post-Civil War Western history that doubles the past back at us in 2016. Hutton’s brilliance as a historian shows in that *The*

52 View on Apache Lake

Wheeler Survey photographer Timothy O'Sullivan's images of Arizona Territory in 1873 were not limited to geologic wonders; rather, he spent quality time taking images of the men and women, soldiers and citizens, and Indian tribes along his route, including these two Apache scouts, and two Buffalo soldiers at Apache Lake in the White Mountains.

— COURTESY LIBRARY OF CONGRESS —



Shakespeare's dramatic understanding that the flawed lives of historical characters also make the best dramatic players, whether in lead or supporting roles.

Standing on the same "Best of 2016" shelf with Hutton's *The Apache Wars* are five books—and five authors—who I believe are "time-skipping"—resetting the boundaries of Old West history with theses, topics and biographies that are accessible and relevant to 21st-century readers: Peter Cozzens' *The Earth is Weeping: The Epic Story of the Indian Wars for the American West*; Joe Jackson's *Black Elk: The Life of an American Visionary*; John Boessenecker's *Texas Ranger: The Epic Life of Frank Hamer: The Man Who Killed Bonnie and Clyde*; Ron Hansen's *The Kid*; Peter H. Hassrick's (editor) *Frederick Remington: A Catalogue Raisonné II*; and Marian Wardle and Sarah E. Boehme (editors) *Branding the American West: Paintings and Films, 1900-1950*.

BEST AUTHOR AND NON-FICTION BOOK OF THE YEAR

The Apache Wars: The Hunt for Geronimo, the Apache Kid, and the Captive Boy Who Started the Longest War in American History by Paul Andrew Hutton (Crown)

The strength of Professor Paul Andrew Hutton's *The Apache Wars* is that it is both the new baseline synthesis for students and historians of U.S.-Apache history and those researching and analyzing the geo-political history, and the present-day multi-national international border wars.

BEST OF THE REST:

- ❶ **Frontier:** *Eternity Street: Violence and Justice in Frontier Los Angeles* by John Mack Faragher (WW Norton)
- ❷ **Fur Trade:** *Hugh Glass: Grizzly Survivor* by James D. McLaird (South Dakota Historical Society Press)
- ❸ **Indian Wars:** *Powder River: Disastrous Opening of the Great Sioux War* by Paul L. Hedren (University of Oklahoma Press)
- ❹ **Military:** *Fighting for Uncle Sam: Buffalo Soldiers in the Frontier Army* by John P. Langillier (Schiffer Military History)
- ❺ **Women/Minorities:** *Sweet Freedom's Plains: African Americans on the Overland Trails, 1841-1869* by Shirley Ann Wilson Moore (University of Oklahoma Press)

BEST BIOGRAPHY

Black Elk: The Life of an American Visionary by Joe Jackson (Farrar, Straus and Giroux)

With access to family members of Lakota spiritual leader Black Elk, investigative journalist-historian Joe Jackson's talents as a writer, interviewer and historian are all on full-display in *Black Elk*, the most evocative, empathetic and comprehensive biography ever written about the Sioux holy man.

BEST OF THE REST:

- ❶ **Law and Order:** *Pat Garrett: The Man Behind the Badge* by W.C. Jameson (Taylor Trade Publishing)
- ❷ **Indian Wars:** *"Hang Them All": George Wright and the Plateau Indian War* by Donald Cutler (University of Oklahoma Press)
- ❸ **Texas Rangers:** *Whiskey River Ranger: The Old West Life of Baz Outlaw* by Bob Alexander (University of North Texas Press)
- ❹ **American Empire:** *Splendid Savage: The Restless Life of Frederick Russell Burnham* by Steve Kemper (WW Norton)
- ❺ **Women:** *Wealth Woman: Kate Carmack and the Klondike Race for Gold* by Deb Vanasse (The University of Alaska Press)



53 Survey Camp

Photographers Timothy O'Sullivan and William Bell chronicled First Lieutenant George H. Wheeler's 1871 to 1873 survey of the 100th Meridian. In 1873, O'Sullivan was on his second tour when the Wheeler party set up at Fort Wingate, New Mexico Territory.

— COURTESY LIBRARY OF CONGRESS —

WESTERN BOOKS



JPS Brown: An American Original

At 86 years old, Arizona's native son is still writing about the border he loves.

One day in 1937, in the bar of Tucson's Santa Rita Hotel, the cowboy-actor Tom Mix gave seven-year-old Joe Brown a pair of buckskin chaps with "Joey" branded on them. Brown had been ill and the Hollywood star, a family friend, wanted to cheer him up.

Sitting in his home in the mountains outside Patagonia, Arizona, Brown remembers that Mix was dressed for town, in a new hat, suit and shiny boots. The boy sure was grateful. But looking at the biggest movie star of the day, all he could think was that his own father, a cowboy from birth, was the real hero.

"Mix wasn't like my dad and uncles," says Brown. "They were working cowboys and, to me, nothing else mattered."

During a lifetime of writing about cowboying in the West and in Mexico, JPS Brown has tried to close that divide between reality and myth. In his 14 short story collections and novels, including his first, *Jim Kane*, which became the 1972 movie *Pocket Money*, the author has told the truth about life in the saddle.

Authenticity is Brown's calling card. His books put trail dust in readers' mouths. His hero is the great cowboy-writer Will James.

"James made his writing about the work," says Brown, "not drinking in town, and men with guns walking down the street, and all that stuff Hollywood loves. The work is good enough, dangerous enough and thrilling enough for anybody."

At 86, Brown is still at it. In April, he released his latest, *Cowboys Fly*, a book of stories that includes an account of the Mix meeting. The collection is part of a new burst of production from Make a Hand, LLC, formed in 2011 with Rick Padilla, a former creative associate to famed film director Hal Ashby.

The company also launched Brown's nonfiction book about Arizona rancher Jim Chilton's successful lawsuit against the Center for Biological Diversity; a CD of cowboy songs produced by five-time Grammy-winner Ray Kennedy; and an audio version of Brown's heartbreaking 2011 novel, *The Spirit of Dogie Long*, about a trail crew raising an orphaned infant.

Grammy-nominated voice coach Jan Smith narrates the book, and a movie version of *Dogie* is currently in production.

In addition to his cowboy work, Brown has been a Marine, a professional boxer in Mexico, and a movie-set wrangler who befriended Paul Newman and Lee Marvin, co-stars of *Pocket Money*.

He taught Steve McQueen how to rope for the 1980 Western, *Tom Horn*. They became good friends and McQueen pulled strings to get Brown the role of the priest who presides over Horn's hanging.

In the West, we call that irony. Brown has lived more adventures than most men do in their dreams. He has struggled with drinking and has been married five times. He bought his third wife out of a Mexican whorehouse for \$50. She tried to kill him twice, once with poison and again by jamming a pistol in his belly and pulling the trigger. The gun misfired.

When he lived in the Mexican Sierra Madre, locals called him *El Mostrenco*, "the unbranded one." But his wild days ended long ago. Brown and his last wife, Patsy, were married for 39 years, until her passing in 2011.

Now he spends his time telling the story of the West he has known since he was a boy in Nogales. He started riding at three and broke his first horse at 12.

"I learned by watching my father," he says. "When something's in your blood, it's not work. I loved everything about cowboying every day I did it."

Does that mean, like James, that Brown has done everything he's written about?

"You're damned right," he says with pride. "My work is one hundred percent autobiographical. That's why I find life so tedious now, because I can't do it anymore."

Brown, who has been recuperating from a hip replacement, gets a far-off look in his eyes and says, "What I wouldn't give to get horseback one more time."

Editor's Note: With his black Lab, Mikey, close by, Joe Brown still writes every day. His latest project is a screenplay that producers plan to film in Durango, Mexico. To order his latest books, go to MakeAHand.com.

WESTERN BOOKS

BEST AMERICAN INDIAN HISTORY

The Earth is Weeping: The Epic Story of the Indian Wars for the American West by Peter Cozzens (Alfred A. Knopf)

Peter Cozzens' *The Earth is Weeping* is the most comprehensive history of the post-Civil War American conflicts with the Western Indian nations written to date. Cozzens' research and conclusions will quickly become one of the favored textbooks for students of past and present Western American Indian history.

BEST OF THE REST:

- 1 **Indian Memoir:** *The Life of Ten Bears: Comanche Historical Narratives*, collected by Francis Joseph Attocknie, edited with an introduction by Thomas W. Kavanagh (University of Nebraska Press)
- 2 **Military Memoir:** *Sign Talker: Hugh Lenox Scott Remembers Indian Country* edited by R. Eli Paul (University of Oklahoma Press)
- 3 **Indian Wars:** *The Terrible Indian War of the West: A History from the Whitman Massacre to Wounded Knee, 1846-1890* by Jerry Keenan (McFarland)
- 4 **Relocation:** *Rivers of Sand: Creek Indian Emigration, Relocation & Ethnic Cleansing in the American South* by Christopher D. Haveman (University of Nebraska Press)
- 5 **Industrialization:** *The Railroad and the Pueblo Indians: The Impact of the Atchison, Topeka and Santa Fe on the Pueblos of the Rio Grande, 1880-1930* by Richard H. Frost (The University of Utah Press)

BEST LAW AND ORDER HISTORY

Texas Ranger: The Epic Life of Frank Hamer: The Man Who Killed Bonnie and Clyde by John Boessenecker (Thomas Dunne Books)

Western historians who draw a line in the sand in 1890, 1900 or even 1920, as the proverbial "End of the Old West" forgot to tell that to Texas lawman Frank Hamer, who was born in the era of steam engines in 1884 and died in the midst of the Atomic Age in 1955. Boessenecker

proves conclusively that the tighter we tie the noose on Western history, the less we understand its importance to the present—and future—West.

BEST OF THE REST:

- 1 **Texas Rangers:** *Texas Ranger Tales: Hard-Riding Stories from the Lone Star State* by Mike Cox (Lone Star Books)
- 2 **Outlaws:** *The Ghosts of Guerrilla Memory: How Civil War Bushwhackers Became Gunslingers in the American West* by Matthew Christopher Hulbert (University of Georgia Press)
- 3 **Criminal:** *No Hope for Heaven, No Fear of Hell: The Stafford-Townsend Feud of Colorado County, Texas, 1871-1911* by James C. Kearney, Bill Stein and James Smallwood (University of North Texas Press)
- 4 **Law & Order:** *The Trial of Tom Horn* by John W. Davis (University of Oklahoma Press)
- 5 **Indian:** *Law at Little Big Horn: Due Process Denied* by Charles E. Wright (Texas Tech University Press)

BEST FICTION

The Kid: A Novel by Ron Hansen (Scribner)

Nebraska native Ron Hansen's latest novel *The Kid* is the fictional life story of William Henry McCarty, aka "Billy the Kid." Hansen, a Santa Clara University English professor, who previously explored the humanity of a Western outlaw in *The Assassination of Jesse James by the Coward Robert Ford*, returns to the chaos of life in the West in the most poignant Billy the Kid novel to date.

BEST OF THE REST:

- 1 **Old West:** *Easy Pickings* by Richard S. Wheeler (Forge)
- 2 **Mystery:** *Jonis Agee The Bones of Paradise* (William Morrow)
- 3 **Traditional:** *News of the World: A Novel* by Paulette Jiles (William Morrow)
- 4 **Frontier Fiction:** *Picketwire Vaquero* by James D. Crownover (Five Star Publishing)
- 5 **Mass Market:** *Return to Red River* by Johnny D. Boggs (Pinnacle)



TRUE WEST

RODEO PATTERN, undeniably the #1 best seller in classic cowboy china!

Texas based TRUE WEST faithfully recreates the original heavy roll rim design featuring Till Goodan's art from the 1940's. CHRISTMAS, BOOTS & SADDLE & LONGHORN patterns also available.

- ★ HEAVY ROLL RIM DESIGN
- ★ MICROWAVE SAFE

As always . . . MADE IN THE USA

Dealer inquiries welcome. Call, fax, write or email for color brochure, complete pricing and details.

Box 441 • Royse City 75189

Ph: 888-636-7922 Fax: 972-635-2059

e-mail: truewesthome@aol.com

WWW.TRUEWESTHOME.COM



Come Party Like It's 1849!

THE GOLD RUSH Museum

Indoor panning stream
Replica mining tunnel
Gold Rush era artifacts
Free Admission!

601 Lincoln Way,
Auburn, CA

placer.ca.gov/museums



**BEST HISTORICAL
NON-FICTION AUTHOR**

Editors' Choice • Paul Andrew Hutton
Readers' Choice • Chris Ens

**BEST HISTORICAL
WESTERN NOVELIST**

Editors' Choice • Ron Hansen
Readers' Choice • Johnny D. Boggs

**BEST WESTERN
ROMANCE PUBLISHER**

Editors' Choice • Bethany House,
Bloomington, MN
Readers' Choice • Harlequin, Don Mills,
Ontario, Canada

**BEST WESTERN HISTORY
BOOK PUBLISHER**

Editors' Choice • The University of
Oklahoma Press, Norman, OK
Readers' Choice • TwoDot/Rowman & Littlefield,
New York, NY

**BEST WESTERN HISTORY
BOOK STORE**

Editors' Choice • Guidon Books, Scottsdale, AZ
Readers' Choice • Guidon Books, Scottsdale, AZ

**BEST WESTERN HISTORY
UNIVERSITY PRESS**

Editors' Choice • Texas A&M University Press
and the Texas Book Consortium,
College Station, TX, including North Texas
University Press and TCU Press
Readers' Choice • University of Nebraska Press,
Lincoln, NE

BEST WESTERN FICTION PRESS

Editors' Choice • Five Star Publishing,
Waterville, ME
Readers' Choice • Pinnacle Books,
New York, NY

BEST WESTERN MUSIC GROUP

Editors' Choice • The Cowboy Way,
Albuquerque, NM
Readers' Choice • Horse Crazy Cowgirl Band,
Winthrop, WA

**BEST SOLO
WESTERN MUSICIAN**

Editors' Choice • R.W. Hampton, Cimarron, NM
Readers' Choice • Juni Fisher, Franklin, TN



Guidon Books



The largest collection of new and out of print Civil War & Western Americana books.

Lincoln and Custer Collections, American Indian History, Arts & Crafts.

Helping collectors and history buffs learn more about specific
events and people in American history.

Bookmaster@Guidon.com • Guidon.com

ONLINE SALES OR VISIT US AT OUR NEW LOCATION

7830 E. Redfield Rd. Suite 1 • Scottsdale, AZ • 480-945-8811



Follow us on Facebook!



Named True West's 'Best Solo Musician'
2010, 2013, 2014, 2015 & 2016



Dave Stamey

Singer! Songwriter!
Entertainer!
Producer!

Catch Dave in
Sonoita, AZ

Feb. 25, 2017

Come for the music,
explore the weekend!



More Arizona tour dates at
www.GoPattyWagon.com

WESTERN BOOKS

BOOT HILL
MUSEUM, INC.
 Relive the Legend...
 Hear the stories of
 Dodge City,
 the heroes, the villains
 and the ladies they loved.
 You can almost
 touch and see 'em...
 at Boot Hill Museum.
 Dodge City...
 making history again!

GENERAL
 FITTING
 STORE
 LONG BRANCH
 G.M.
 CHARLES P.
 LOVE
 \$4.00

boothill.org
620-227-8188



54 Stream Gaging

Nineteenth-century survey teams and frontier hydrologists had to be enterprising and entrepreneurial in their attempts to measure the flow of rivers and streams of the West. In 1889, a U.S. Geological Survey team placed the nation's first stream-gaging station on the Rio Grande near Embudo, New Mexico Territory.

— COURTESY NATIONAL ARCHIVES AND RECORDS ADMINISTRATION —

BEST CULTURAL WEST

Branding the American West: Paintings and Films, 1900-1950, edited by Marian Wardle and Sarah E. Boehme (University of Oklahoma Press)

The beautifully designed, well-edited and superbly written collection of essays and criticism edited by Marian Wardle and Sarah E. Boehme provides insightful and thoughtful support to the Brigham Young University Museum of Art and the Stark Museum of Art's joint exhibition titled *Branding the American West: Paintings and Films, 1900-1950*.

BEST OF THE REST:

- ❶ **Biography:** *Rounded Up in Glory: Frank Reaugh, Texas Renaissance Man* by Michael R. Grauer (University of North Texas Press)
- ❷ **Tourism:** *Imagining Tombstone: The Town Too Tough to Die* by Kara L McCormack (University Press of Kansas)
- ❷ **Western Literature:** *Westerns: A Women's History* by Victoria Lamont (University of Nebraska Press)
- ❹ **Western Culture:** *Encyclopedia of Weird Westerns, Supernatural and Science*

Fiction Elements in Novels, Plus, Comics, Films Television and Games... by Paul Green, 2nd Edition (McFarland)

❸ **Modern Western Film:** *The New Western: Critical Essays on the Genre Since 9/11* edited by Scott F. Stoddart (McFarland)

BEST ART/ ILLUSTRATED BOOK

Frederic Remington: A Catalogue Raisonne II edited by Peter H. Hassrick (University of Oklahoma Press)

Editor Peter H. Hassrick's essay, "Finding the Real Frederic Remington," sets the tone for *Frederic Remington: A Catalogue Raisonne II*, an expertly edited collection of essays and beautifully reproduced catalogue of artwork by the most influential Western artist in history.

BEST OF THE REST:

- ❶ **Historic:** *American Saloons: Pre-Prohibition Photographs* by Roger E. Kisingbury (REK)
- ❷ **Cultural:** *Photographing Custer's Battlefield: The Images of Kenneth F. Rothen* by Sandy Barnard (University of Oklahoma Press)

ROUGH DRAFTS

WESTERN BOOKS ROUND-UP 2016 10 FAVORITES

In 2016, Western fiction and non-fiction remained strong segments in the catalogues of national, regional and university publishers, with Mystery and Romance genres dominating sales. Ten books and authors I recommend:

FICTION:

Civil War: *Captain Grimes:*

Unreconstructed: The Gaslight Boys by John T. Wayne (Mockingbird Lane Press)

Frontier: *Mariano's Choice: A Novel* by David M. Jessup (Pronghorn Press)

Mystery: *What Gold Buys: A Silver Rush Mystery* by Ann Parker (Poisoned Pen Press)

Old West: *T.H. Elkman* by Eric H. Heisner (Skyhorse Publishing)

20th-Century West: *Stripped Bare* by Shannon Baker (Forge)

HISTORY:

Biography: *Rough Riders: Theodore Roosevelt: His Cowboy Regiment, and the Immortal Charge Up San Juan Hill* by Mark Lee Gardner (HarperCollins)

Empire & Exploration: *Jefferson's America: The President, the Purchase, and the Explorers who Transformed a Nation* by Julie M. Fenster (Crown)

Environment: *Bitter Waters: The Struggles of the Pecos River* (University of Oklahoma Press)

Law & Order: *Tall Tales & Half Truths of Pat Garrett* by John LeMay (The History Press)

Western History: *The Wild West Meets the Big Apple* by Michael P. O'Connor (Pelican Publishing)

—Stuart Rosebrook



FULL OF HISTORY. There's plenty to see and do. Plan a Cody, Wyoming vacation now. 1-800-393-2639 or yellowstonecountry.org.



Buffalo Bill's
CODY, YELLOWSTONE COUNTRY

THE WILDEST WAY INTO YELLOWSTONE.

John Wayne Birthplace & Museum

The only museum in the world dedicated to John Wayne.

205 South John Wayne Drive • Winterset, Iowa 50273 USA
Toll-Free (877)-462-1044 • www.johnwaynebirthplace.museum

WESTERN BOOKS

BOB BOZE BELL BOOKS



BAD MEN, OUTLAWS & GUNFIGHTERS
(hard cover only)

Illustrated bios, featuring many never-before published images.

\$18.95 *Plus S&H

Check out his other books on our web site!

TRUE WEST

www.TrueWestMagazine.com

I'm Your Huckleberry!



100% Cotton / Most sizes:

\$24.95 each + S&H

TRUE WEST

Store.TrueWestMagazine.com

or call

888-687-1881

55 Mohave Indians

In 1871, the Wheeler Survey went 200 miles in 30 days up the Colorado River to the Grand Canyon.

Photographer Timothy O'Sullivan photographed many of the Mohave Indians, including Maiman, hired to help the surveyors' journey up the wild river.

— COURTESY NATIONAL ARCHIVES AND RECORDS ADMINISTRATION —



3 Regional: *Picturing Indian Territory: Portraits of the Land that Became Oklahoma, 1819-1907* edited by B. Byron Price (University of Oklahoma Press)

Portraits of the Land that Became Oklahoma, 1819-1907 edited by B. Byron Price (University of Oklahoma Press)

4 Travel: *Our Indian Summer in the Far West: An Autumn Tour of Fifteen Thousand Miles in Kansas, Texas, New Mexico, Colorado, and the Indian Territory* by S. Nugent Townshend ("St. Kames" of "The Field"), illustrated by J.G. Hyde, edited by Alex Hunt and Kristin Loyd (University of Oklahoma Press)

5 Cowboy Culture: *Cowboys of the Waggoner Ranch* photography by Jeremy Enlow, text by Jan Nichols Batts (Jeremy Enlow Fine Art Photography)

BEST WESTERN ROMANCE

***This Road We Travelled* by Jane Kirkpatrick (Revell)**

Worldwide, Romance novels generate \$1.2 billion in revenue annually. Western Romance is currently a major segment of the genre, including Amish, Bridal, Christian, Cowboy/Cowgirl, Erotic, Fantasy, Frontier, Gothic, Historical, Horror, Modern, Mystery, Outlaw, Ranching and Thriller. Jane Kirkpatrick's *This Road We Travelled* showcases her talents as a Romance author and researcher, blending history with love into a heart-warming tale on the Oregon Trail.

BEST OF THE REST:

1 Thriller: *Bandita Bonita and Billy the Kid: The Scourge of New Mexico* by Nicole Maddalo Dixon (Sunstone Press)

2 Outlaw: *The Innocent and the Outlaw* by Harper St. George (Harlequin)

3 Historical: *No Other Will Do* by Karen Witemeyer (Bethany House)

4 Ranching: *No Way Up* by Mary Connealy (Bethany House)

4 Modern: *Wild Montana Skies* by Susan May Warren (Revell)

BEST NEW WESTERN AUTHOR

Benjamin Madley

Benjamin Madley is *True West's* "Best New Western Author" for 2016 for his comprehensively researched and well-written *An American Genocide: The United States and the California Indian Catastrophe* (Yale University Press). Madley is a UCLA associate professor of history, and *An American Genocide* courageously challenges the status quo—with primary sources—about how the state and federal government were involved in the decimation of the California Indian tribes.

THE LAST ROUNDUP

Paul Aiken, 1959-2016

Paul Aiken, the former executive director of the Author's Guild, died January 29, of ALS, at age 57.

Matt Braun, 1932-2016

Matt Braun, author of 52 Western novels, was awarded the WWA Owen Wister Award in 2004. He died at 83 years old on March 21.

Lenore Carroll, 1930-2016

Kansas City, Missouri, author and English teacher Lenore Carroll, who published 24 short stories and six novels, died on May 27.

Paul Cool, 1950-2016

Author Paul Cool, best known for *Salt Warriors: Insurgency on the Southwest Border*, died at the age of 66 in Scottsdale, Arizona, on July 28.

Richard H. Dillon, 1924 -2016

Renowned Western historian, educator, librarian and author Richard H. Dillon died at the age of 97 in Mill Valley, California, on July 7.

Ed Gorman, 1941-2016

WWA Spur award-winner Ed Gorman died at age 74 in Cedar Rapids, Iowa, on October 14.

Earl Hamner Jr., 1923-2016

For sixty years, few writers had as much influence on television history as Earl Hamner Jr., best known for *The Waltons*. He died in Los Angeles on March 24 at the age of 92.

James L. Hester, 1931-2016

University of Colorado professor emeritus of anthropology James L. Hester was 84 years old when he passed away in Boulder on January 12.

H. Joaquin Jackson, 1935-2016

Texas Ranger and author H. Joaquin Jackson died at the age of 80 on June 15 in Alpine, Texas.

Paul Joseph Lederer, 1944-2016

Prolific Western author Paul J. Lederer, best known for his eight-book "Indian Heritage" series, died in La Mesa, California, on January 30.

Jack Page, 1936-2016

Mystery writer, editor, historian and Spur Award-winner Jack Page died at the age of 80 at his Lyons, Colorado, home on February 10.

Miles Swarthout, 1946-2016

Miles Swarthout died at home in Playa Del Rey, California, on March 2. He was best known for a screen adaption of his father's novel, *The Shootist*. Miles's final novel, *The Last Shootist*, was *True West's* best Western novel of 2014.

Jon Tuska, 1942-2016

Jon Tuska died at the age of 73 on January 18 at his home in Portland, Oregon. The literary agent also wrote or edited more than 30 books, many on Western film and literature.

DISCOVER OUR WINTER WONDERLAND

November 23, 2016
through May 5, 2017



Standard departure/return will be 9:45am and 2:45pm



CASCADE CANYON TRAIN

This five-hour roundtrip journey takes you through the winter wonderland of the San Juan Mountains. This wilderness destination is the perfect setting for a fire-side lunch, photo opportunities, or a walk along the Animas River.



Visit our website or call us today
to reserve your winter adventure!

DurangoTrain.com
888-872-4607

WESTERN BOOKS

BEST WESTERN HISTORY PUBLISHER

The University of Oklahoma Press

The University of Oklahoma Press has set the standard for publishing the history of the North American West for over 90 years, and its current Western history catalogue is unequalled amongst university imprints.

BEST OF THE REST:

- ❶ **National:** W.W. Norton; New York, New York
- ❷ **University:** Texas A&M University Press and the Texas Book Consortium, including University of North Texas Press and TCU Press
- ❸ **Regional:** South Dakota Historical Society; Pierre, South Dakota

❸ **Old West History:** McFarland; Jefferson, North Carolina

❹ **Trade:** TwoDot/Rowman & Littlefield; Lanham, Maryland

BEST WESTERN FICTION PUBLISHER

Five Star Publishing

Five Star Publishing, an imprint of Gale Cengage Learning in Waterville, Maine, is currently publishing more Western and Frontier titles than any other publisher of Western fiction. Under the editorial direction of Tiffany Schofield, editors are guiding and encouraging a very diverse group of authors—many of them first-time authors—to create a catalogue of Old West fiction that will remind readers of the glory days of Dell and Bantam.

BEST OF THE REST:

- ❶ **National:** Forge; New York, New York
- ❷ **University:** The University of California Press; Berkeley, California
- ❸ **Electronic:** Wolfpack Publishing, LLC; Las Vegas, Nevada
- ❹ **Regional:** Poisoned Pen Press; Scottsdale, Arizona
- ❺ **Mass Market:** Pinnacle; New York, New York

BEST WESTERN BOOKSTORE

Guidon

7830 E. Redfield Rd. Suite 1
Scottsdale, Arizona 85260
Guidon.com (480) 945-8811

With over fifty years in the Western book business in Arizona, Guidon has recently moved to a new location to serve its customers more efficiently from a storefront in the Scottsdale Airpark, as well as an expanded online store. Call owner Shelly Dudley for current hours and/or to make a special appointment.

BEST OF THE REST:

- ❶ **Large:** Powell's City of Books; Portland, Oregon, *Powells.com*
- ❷ **Medium:** Collected Works Bookstore and Coffeehouse; Santa Fe, New Mexico, *CWBookstore.com*
- ❸ **Small:** Hole in the Wall; Wall, South Dakota, *Wall-Drug.Myshopify.com*
- ❹ **Specialized:** The Poisoned Pen Bookstore; Scottsdale, Arizona, *PoisonedPen.com*
- ❺ **Writer's Haven:** Tattered Cover Book Store; Denver, Colorado, *TatteredCover.com*



1st Lieut. GEO. M. WHEELER,
CORPS OF ENGINEERS, IN CHARGE.

56 Fort Garland

Fort Garland in Colorado's San Luis Valley was founded in 1858. The post was showing its age when Wheeler Survey photographer Timothy O'Sullivan posed these soldiers at the main entrance to the fort on his last expedition in 1874.

— COURTESY LIBRARY OF CONGRESS —

BEST OF THE BEST ROUNDUP

TRAVEL HISTORY

Travel is a strong segment of Western publishing and is interpreted in many different genres, including personal memoir, community, tourism and transportation history. Current and classic Western travel provides a great personal window into the West's present and past.

- 1 *Last Chance Byway: The History of Nine Mile Canyon*, by Jerry D. Spangler and Donna Kemp Spangler (The University of Utah Press)
- 2 *Lost Ghost Towns of Teller County* by Jan Mackell Collins (The History Press)
- 3 *The Mighty Colorado River: From the Glaciers to the Gulf* by Jim Turner (Rio Nuevo Publishers)
- 4 *Over the Edge: Fred Harvey at the Grand Canyon and in the Great Southwest* by Kathleen L. Howard and Diana F. Pardue (Rio Nuevo Publishers)
- 5 *The Texas Frontier and the Butterfield Overland Mail, 1858-1861* by Glen Sample Ely (University of Oklahoma Press)

WOMEN IN THE WEST

Publishers across the board are adding to their catalogues strong volumes of history, biography and fiction about women in the West. Here is a sampling of four diverse volumes of history, and one fictional biography of Josephine Marcus.

- 1 *All for the Greed of Gold: Will Woodin's Klondike Adventure* edited by Catherine Holder Spude (Washington State University Press)
- 2 *Frontier Grit: The Unlikely True Stories of Daring Pioneer Women* by Marianne Monson (Shadow Mountain)
- 3 *The Last Woman Standing: A Novel* by Thelma Adams (Lake Union Publishing)
- 4 *Soap Suds Row: The Bold Lives of Army Laundresses, 1802-1976* by Jennifer J. Lawrence (High Plains Press)
- 5 *Soldier, Sister, Spy, Scout: Women Soldiers and Patriots on the Western Frontier* by Chris Enss and Joann Chartier (TwoDot)

Another new and exciting Western novel by

LEE MARTIN

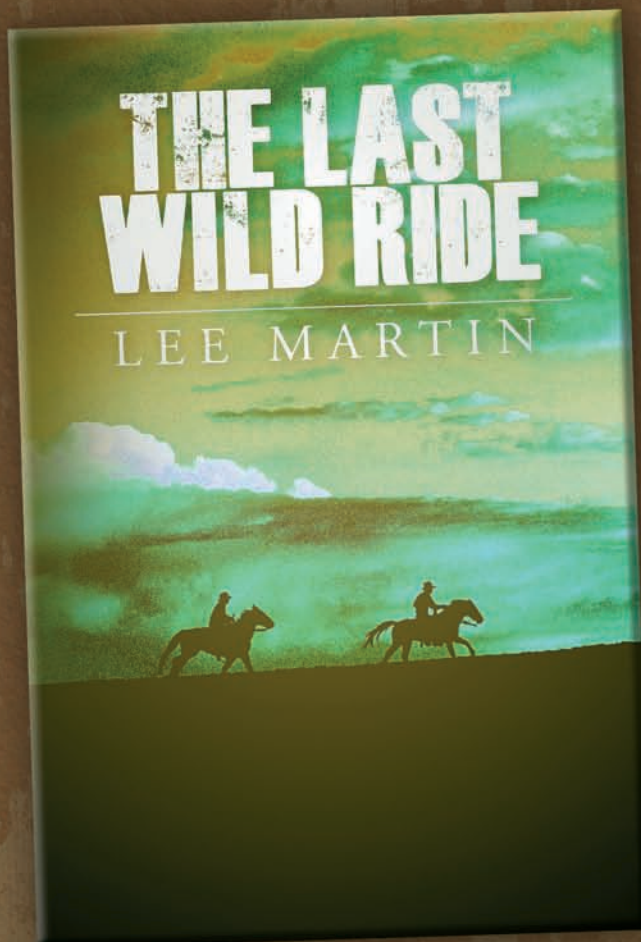

In 1877, Sam Jeffries, a shot up, beat up, bitter ex-lawman finds himself roped into escorting Lorena Ramsey, a fugitive widow, and her mute son on a wild ride south. Aided by old scouts and a troublesome, lecherous gambler, they fight their way down through Colorado's mesa country, across the flooded Grand River, and through the badlands of New Mexico Territory as they head for Texas. All the while, a Ramsey lynch mob led by her vengeful ex mother-in-law is hot on their trail.

Based on Lee Martin's screenplay. Watch for it and Lee Martin's 19 other Western novels on AMAZON or wherever books are sold.

Don't miss Lee's *THE GRANT CONSPIRACY*, reviewed by *True West Magazine*, and *SHADOW ON THE MESA*, from which Lee wrote the highly rated movie with Kevin Sorbo.

Amazon.com

Many are on audio with BOOKS IN MOTION.

WESTERN BOOKS

WEAPONS, VIOLENCE AND WAR IN THE WEST

Violence in the American West has been a favorite topic of authors and publishers for many years. Reviewing it from different perspectives, including one-sided warfare, law enforcement, technology, sociology and industrialization provides a broader interpretation of the cause and effects—and the long-range ramifications—of weapons, violence and war in the West.

- ❶ *Blood on the Marias: The Baker Massacre* by Paul R. Wylie (University of Oklahoma Press)
- ❷ *Edward J. Steptoe and the Indian Wars: Life on the Frontier, 1815-1865* by Ronald McFarland (McFarland)
- ❸ *Riding for the Lone Star: Frontier Cavalry and the Texas Way of War, 1822-1865* by Nathan A. Jennings (University of North Texas Press)

❹ *Thundersticks: Firearms and the Violent Transformation of Native America* by David L. Silverman (The Belknap Press of Harvard University Press)

❺ *The Winchester: The Gun that Built an American Dynasty* by Laura Trevelyan (Yale University Press)

SELF-PUBLISHED AND SMALL PRESS

Western authors of fiction and non-fiction are using all available platforms, small presses and self-publishing, to push their stories out to the public in a dynamic, fluid world of communications.

- ❶ *Death after Life: Tales of Nevada* by William A. Douglas (Black Rock Institute)
- ❷ *Devil on the Loose* by Doug Hocking (Buckland Abbey, LLC)
- ❸ *Mary Fields aka Stagecoach Mary* by Erich Martin Hicks (First Edition E Books)

❹ *Shootout in Cheyenne* by Joe Corso (Black Horse Publishing)

❺ *Way Before Daylight Long After Dark: A New Mexico Rancher's Story* by Carl Lane Johnson (Lea County Museum Press)

20TH- TO 21ST-CENTURY WESTERN FICTION

While the Mystery and Romance genres and their many sub-categories dominate post-1920 Western fiction, many traditional, contemporary authors continue to set their literary novels in the West. A selection:

- ❶ *Buffalo Jump Blues* by Keith McCafferty (Viking)
- ❷ *Cowboys Fly: Book One* by JPS Brown (Make a Hand Publishing LLC)
- ❸ *Midnight Crossing: A Mystery* by Tricia Fields (Minotaur Books)

GET YOUR FREE CD

WHEN YOU SUBSCRIBE TO TRUE WEST!



Order a one-year subscription to *True West* Magazine and receive this never before released CD. Enjoy 18 songs that share the memories and tales of the working cowboy, all performed by a one of a kind entertainer, Romaine Lowdermilk.

Only \$29.95



Sign me up!

Name _____
 Address _____
 Phone _____ Email _____
 American Express Discover MasterCard Visa
 Card Number _____ CVC _____ Exp. Date ____/____/____

P. O. Box 8008, Cave Creek, AZ 85327 • 1.888-687-1881

*You must use this mailer to receive your CD • Limited quantity while supplies last!
 Payment must be included with this order. • No overseas orders, USA Only*

*As seen in True West Magazine's August 2016 issue

57 Vernal Falls

California pioneer photographer Carleton E. Watkins's images of Yosemite helped promote its federal protection in 1864. In 1861, with his custom made 18 x 22-inch glass plate camera, he ventured to Yosemite and photographed Vernal Falls.

— COURTESY LIBRARY OF CONGRESS —



4 *The Necessary Murder of Nonie Blake* by Terry Shames (Seventh Street Books)

5 *Showdown City: A Novel* by Todd Berger (Diversion Books)

20TH- AND 21ST-CENTURY WESTERN NONFICTION

When does the Old West end and the Modern West begin? Historians of 20th- and 21st-century Western nonfiction have the opportunity to expand our understanding of what the West is today through a prism of topics including gender, racial, economic, cultural and environmental history.

1 *Cowboys and Gangsters: Stories of an Untamed Southwest* by Samuel K. Dolan (TwoDot)

2 *Convict Cowboys: The Untold History of Texas Prison Rodeo* by Mitchel P. Roth (University of North Texas Press)

3 *Counterpunch: The Cultural Battles Over Heavyweight Prizefighting in the American West* by Meg Frisbee (University of Washington Press)

3 *Forging the Star: The Official Modern History of the United States Marshals Service* by David S. Turk (University of North Texas Press)

3 *Ma Barker: America's Most Wanted Mother* by Howard Kazanjian and Chris Enss (TwoDot)

FINAL POST: POSTHUMOUSLY PUBLISHED

Jim Harrison

Noted Western author Jim Harrison died at his home in Patagonia, Arizona, on March 26, 2016. Harrison wrote 21 novels, as well as poetry. His last volume of poetry, *Dead Man's Float* (Copper Canyon Press), was published in January, and his final collection of three novellas, *The Ancient Minstrel* (Grove Press), was published in August.



AMERICANA, POLITICAL & LEGENDS OF THE WEST

December 3, 2016 | Dallas | Live & Online

Thanks, *True West* Readers, for Voting Heritage as the "Best Old West Collectibles" Auctions for the 6th Consecutive Year!

Featured here are some of the fine Western items in our upcoming auction.



Extremely rare Tombstone check made out to and endorsed by Kate Holliday
Opening Bid \$3,000



Important engraved Henry rifle with Contention, Arizona Territory connection
Opening Bid \$15,000



Fine cigar store figure from the workshop of Julius Theodore Melchers
Opening Bid \$10,000

View all lots and bid at **HA.com/6168**

For inquiries, please call 877-HERITAGE (437-4824)
Tom Slater | Director of Americana | ext. 1441 | TomS@HA.com
Don Ackerman | Consignment Director | ext. 1736 | DonA@HA.com

DALLAS | NEW YORK | BEVERLY HILLS | SAN FRANCISCO | CHICAGO | PALM BEACH
PARIS | GENEVA | AMSTERDAM | HONG KONG

Always Accepting Quality Consignments in 40 Categories
Immediate Cash Advances Available
1 Million+ Online Bidder-Members

Paul R. Minshull #16591. BP 12-25%; see HA.com 43451

HERITAGE
AUCTIONS
THE WORLD'S LARGEST
COLLECTIBLES AUCTIONEER

The Smoke Wagon™

Short-Stroke Option



Calibers



*You gonna skin that Smoke Wagon™
or just sit there and read?*

Grips



Standard

Birdsheed

Gunfighter

Barrel Lengths

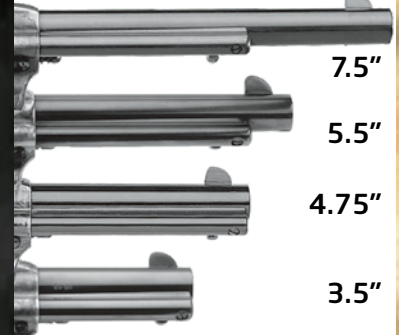

7.5"

5.5"

4.75"

3.5"

Finishes



Blue / Case
Hardened



Antique



Nickel



Stainless



Engraved

* Not all features available on all models. Please visit TaylorsFirearms.com for available configurations.

info@taylorsfirearms.com taylorsfirearms.com
304 Lenoir Drive Winchester, VA 22603
P:540-722-2017



TAYLOR'S & COMPANY
Keeping the Legend Alive

FIREARMS

BY PHIL SPANGENBERGER

A Fistful of Thunder

Colt's 1877 Self Cocker, in .41 Long Colt caliber, better known as the Thunderer, packed its punch in a relatively small package.

The British affinity for double-action (DA) revolvers led to a number of imports into the American West over the years, like the popular Bulldog revolver. By the mid-1870s, these rapid-shooting sidearms gained enough favor that in 1877, Colt finally brought out its first DA revolver. When the '77 was initially produced, Colt dubbed it a "New Double Action, Self Cocking, Central Fire, Six Shot Revolver." Noting that the six-gun's DA capabilities allowed for quite rapid firing, Colt's major distributor, B. Kittredge of Cincinnati, Ohio, coined the monikers of "Lightning" for the .38 caliber, and "Thunderer" for the .41 bore, but ironically it is the Lightning name that stuck. Around 200 were produced in .32 Colt caliber (called "Rainmaker"), but these are extremely rare today. It is the .41 Long Colt-chambered Thunderer that we'll focus on here.

Built around scaled-down lines of its 1873 Single Action Army revolver, but with a bird's-head grip, larger trigger guard, and in DA, this self-cocker, regardless of caliber, the Thunderer was plagued with problems that resulted in all too frequent breaking of its intricately shaped, highly flexed internal springs, and an action that was often out of sync.



Although these 1880s Texas Rangers are well outfitted with 1873 Winchesters and '73 Colts, the man at left has decided to also pack a small '77 DA Colt as backup, quite possibly in .41 Long Colt caliber. This nicked (with heat-blued screws) and pearl-stocked (optional), 5-inch barreled .41 Long Colt Thunderer model was made in 1892, and later carried in El Paso, Texas, during the Mexican Revolution of 1910.

— TEXAS RANGERS PHOTO TRUE WEST ARCHIVES / COLT PHOTO COURTESY PHIL SPANGENBERGER COLLECTION —

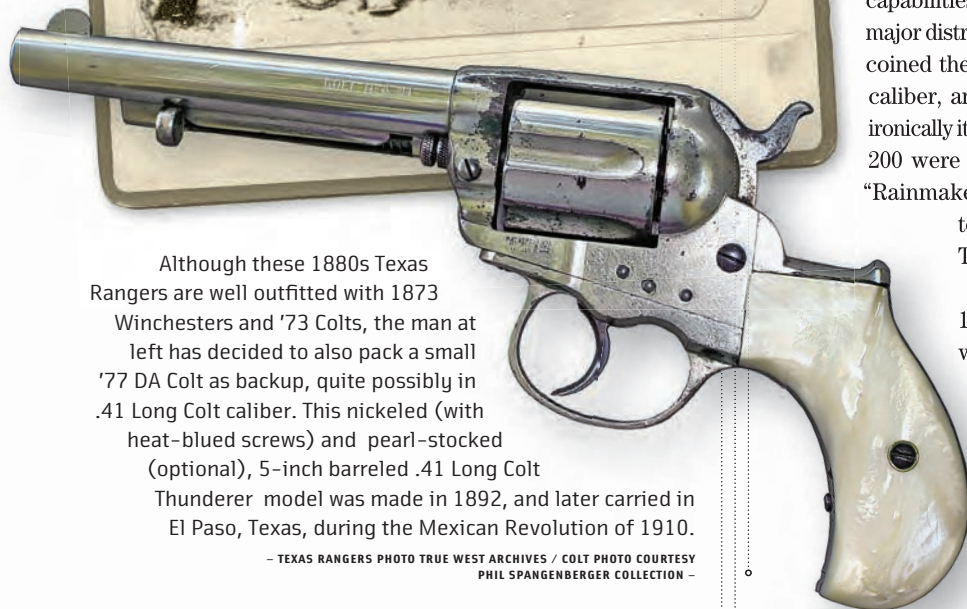

FIREARMS

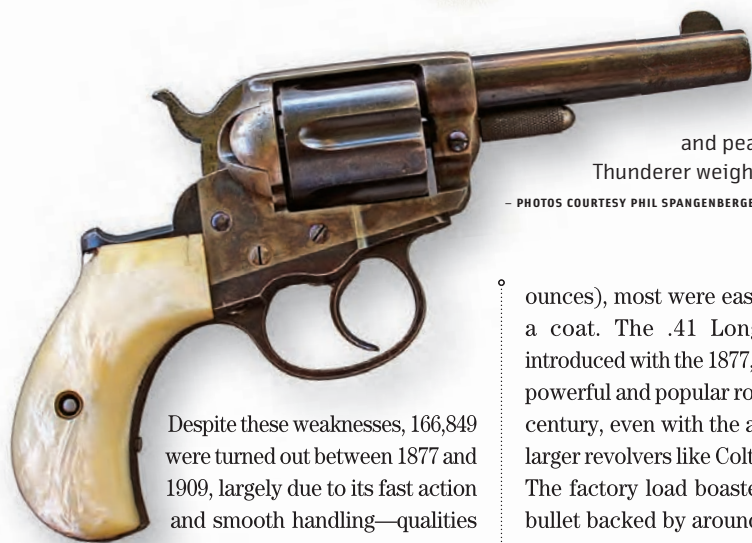

Despite these weaknesses, 166,849 were turned out between 1877 and 1909, largely due to its fast action and smooth handling—qualities that endeared it to many, especially in the West!

The .41 Long Colt Thunderer is probably best remembered as the oft-used six-gun of outlaw William Bonney, aka Billy The Kid, as witnessed by Westerner Frank Collinson, in 1878, when he ran across the young gunman. Collinson recalled that the Kid was not much to look at, and was shabbily dressed, but had his “...ever-ready Colt double-action .41 pistol around him and in easy reach...” The '77 Thunderer was also packed by outlaw Cole Younger and infamous Texas shootist John Wesley Hardin, as well as lawman Pat Garrett, who was presented with a silver-handled .41 Colt while serving as a customs collector in 1903.

These hard cases preferred the .41 Long Colt as their pocket revolvers for good reasons. Barrel lengths ran from 1½ to 10 inches, with the norm running at 2½ to 3½ inches without an ejector and 4½ to 6 inches with an ejector. Lightweight (the 6-inch barrel with ejector weighed 27

Although just slightly smaller in overall size, one can see how Colt's 3-inch ejectorless, .41 Colt, M-1877 DA could be somewhat easier to conceal than a standard-framed 1873 Single Action Army. For size comparison (left to right), a 200-grain .41 Long Colt round is shown with a 200-grain .38 Special, and a 250-grain .45 Colt cartridge.

Ejectorless '77 Colts could be had with barrels up to 4½ inches. An ideal fistful of Thunder, this blue, color-cased and pearl-stocked, 3½-inch ejectorless “Storekeeper” .41 caliber Thunderer weighs just 23 ounces. It left the factory in 1887.

— PHOTOS COURTESY PHIL SPANGENBERGER COLLECTION UNLESS OTHERWISE NOTED —

ounces), most were easy to conceal under a coat. The .41 Long Colt cartridge, introduced with the 1877, became a relatively powerful and popular round in the late 19th century, even with the availability of some larger revolvers like Colt's '73 Single Action. The factory load boasted a 200-grain lead bullet backed by around 20 to 21 grains of black powder that produced a muzzle velocity of 730 feet per second (fps) and about 235 foot pounds of energy. This packed slightly more punch than the Lightning's .38 Long Colt, 150-grain lead projectile, moving at 770 fps, with 195 foot pounds of muzzle energy, and was comparable to a modern .38 Special with a 200-grain lead bullet.

Although Colt's 1877 DA revolver has the dubious honor of having the worst double-action system ever devised, in new condition, the Thunderer was considered an efficient six-gun. However, when actually used much, inherent weaknesses showed in its design. Based on its longevity and production figures, the gun-buying public of the late 19th century was willing to overlook its faults—probably because most handguns were simply carried more than they were actually fired. The '77 Colt in .41 caliber could be considered the .38 Special of its day, and in the relatively

compact size of the Thunderer, it made for one helluva six-shooter—one of the classics of the Wild West!

Phil Spangenberg has written for *Guns & Ammo*, appears on the History Channel and other networks, produces Wild West shows, is a Hollywood gun coach and character actor, and is *True West's* Firearms Editor.

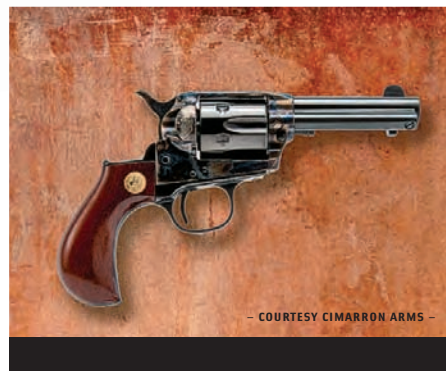

— COURTESY CIMARRON ARMS —

A MODERN .41 THUNDERER

Colt's 1877 DA revolver suffered from complicated and fragile internal mechanisms, so Cimarron Arms' founder and president Mike Harvey designed a single-action (SA) version. Called the “Lightning,” like the original DA pistols, Cimarron's SA offers a more reliable and durable six-gun than the 19th-century model, giving today's shooter the looks and heft of the 19th-century Thunderers with single-action simplicity and 21st-century reliability. This small-framed, bird's-head gripped SA is available in .41 Long Colt, too, as well as .45 Colt, .38 Special and .22 Long Rifle, with 3½-inch (shown), 4¾-inch, 5½-inch, or 6½-inch barrels. As Doc would say, “It's a Daisy!”

Cimarron-Firearms.com





TRUE WEST
WESTERN ARTS AND CULTURE CENTER
TOP 10
MUSEUMS
OF THE WEST
2016

CODY, WYOMING

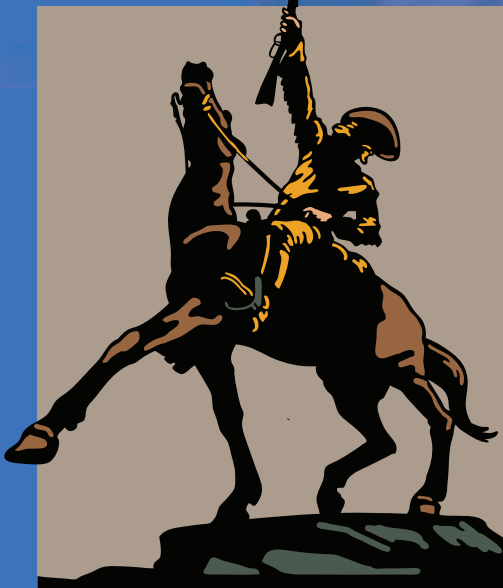

100

YEARS 1917–2017

BUFFALO BILL CENTER OF THE WEST

- Just east of Yellowstone.
- Five museums – one price.
- tickets.centerofthewest.org.

IMAGE: Larry Pirnie (b. 1940). *A Wild West Welcome*, 2009.
Acrylic on board. Buffalo Bill Center of the West,
Cody, Wyoming, USA. Gift of the Artist. 17.09

 Smithsonian Affiliations



58 Eager for Deer

William Henry Jackson, whose photographs helped influence the establishment of Yellowstone Park, also was a master of the still life, such as this image of a hunter with his deer-hunting beagles, circa 1880-97.

- COURTESY LIBRARY OF CONGRESS -

■ BEST GUNLEATHER ARTISAN

Old West Reproductions, Florence, MT

Old West Reproductions artisans handcraft gun leather products "made in the tradition of the Old West" and modeled meticulously after products originally used from 1849 to 1900. Personal customer satisfaction and custom work are hallmarks of Old West Reproduction's President Rick M. Bachman.

OldWestReproductions.com

READERS' CHOICE:

John Bianchi Frontier Gunleather, Cathedral City, CA

■ BEST FIREARM ENGRAVER

A&A Engraving, Rapid City, SD

For 40 years, A&A Engraving has been America's trusted choice for fine commemorative firearms. The company offers complete custom design services, resulting in heirloom quality showpieces that honor the unique communities, businesses, organizations and individuals who have built, protected and continue to serve the United States of America.

AAEngraving.com

READERS' CHOICE:

American Legacy Firearms, Fort Collins, CO

■ BEST COWBOY ACTION PISTOL

Taylor's Smokewagon, Winchester, VA

Taylor's & Co.'s exclusive second-generation, stagecoach-style, single-action revolver, The Smoke Wagon, has a blue finish with a case-hardened frame, and a thin, richly detailed, checkered grip for comfort and improved aim. The Smoke Wagon is an exclusive, trademarked sidearm of the Winchester, Virginia, firearm company. The deluxe Smoke Wagon includes custom tuning, a custom hammer and base pin

Your source for cowboy shooting supplies, obsolete and cowboy ammunition!



Outfitters to the Old West!



8am - 4:30pm M - F PST
660 Vermeer Court, Ponderay, ID 83852

208 263-6953

WWW.BUFFALOARMS.COM

IT'S MORE THAN A RIFLE,
IT'S HISTORY!



Genuine S. Hawken
Classic Plains Rifle
Made in the USA



www.thehawkenshop.com
The Hawken Shop • Oak Harbor, WA

FREE CATALOG!

CLASSIC
OLD WEST STYLES



Classic Western Leather & New Versions of Old Favorites



Priced for the working man.



1-800-595-2697

WWW.COWS.COM

FIREARMS

springs, a trigger pull set at three pounds, jig-cut, positive angles on all triggers and sears for crisp, reliable action, and a wire bolt spring.

TaylorFirearms.com

READERS' CHOICE:
Ruger's Vaquero, Fairport, NY

BEST COWBOY ACTION RIFLE
Uberti's 1873 Winchester, Accokeek, MD

Known worldwide as "the rifle that won the West," the Winchester 1873 Rifle and Carbine is manufactured by Uberti in seven distinctive models, including an Uberti 1873 Carbine, Uberti 1873 Special Sporting Rifle, Uberti 1873 Trapper and Uberti 1873 Half Octagon Rifle.
Uberti.com

READERS' CHOICE:
*Marlin's 1895 Cowboy
Madison, NC*

1873

59 Camp Apache

Timothy H. O'Sullivan ingratiated himself with local Indian tribes on his three survey trips with Lt. George Wheeler, including a group of Apache braves at Camp Apache in 1873.

- COURTESY LIBRARY OF CONGRESS -

INDIAN SERIES.

T. H. O'Sullivan, Phot.

No. 60—Apache Braves

Ammunition

*In a place where few people come,
and fewer still make it,
you stick together.*

We're well versed in subtlety, because only tiny nuances can distinguish flawless ammunition from its lesser ilk. So as a team we scrutinize every round we make, by hand. We may be looking for the most microscopic of mistakes. But it's unquestionably the biggest thing we do.

www.black-hills.com | 605 348 5150 | We sell dealer direct

PRESCOTT ARIZONA
 INVITES YOU TO EXPERIENCE THE OLD WEST



928-499-0699

«12th Annual»
SHOOTOUT ON WHISKEY ROW
 July 22 & 23, 2017
 WWW.PRESCOTTREGULATORS.ORG
 THE PRESCOTT REGULATORS & THEIR SHADY LADIES, INC.

Old West Reproductions, Inc.
 Frontier Gun Leather & Accessories from 1849 to 1900

Affordable Museum Quality Reproductions
 Patterned from original pieces in my collection
 Specializing in custom work

Montana made, in the tradition of the Old West since 1978

Rick M. Bachman | 406.273.2615
 446 Florence South Loop, TW
 Florence, MT 59833



#32 Cheyenne Holster
 For 7 1/2" Colt SA and
 #26 Double Row Money
 Cartridge Belt.

www.oldwestreproductions.com

FIREARMS



60 The Grizzly Giant

In 1865-66 Galen Clark, frontiersman and Yosemite Valley conservationist, posed for Carleton E. Watkins in front of "The Grizzly Giant," 33 feet in diameter, in the Mariposa Grove.

- TRUE WEST ARCHIVES -

BEST COWBOY ACTION SHOTGUN

Cimarron Firearms' 1887 Lever Action Terminator, Fredericksburg, TX

Modeled after an original in the Cimarron Firearms private collection, the five-shot smoothbore 1887 Lever Action Terminator repeating shotgun first went on sale in the spring of 1888. The shotgun quickly became a favorite of law-enforcement officers across the

West. Today's, Cimarron 1887 Lever Action Terminator is available in either a 22-, or 28-inch round blued barrel, a color case hardened receiver, in 12 gauge and capable of handling 2¾-inch shotshells.

Cimarron-Firearms.com

READERS' CHOICE:
Century Arms' 1887 Lever Action Shotgun, Delray Beach, FL

BEST SINGLE SHOT RIFLE

Shiloh Sharps' 1874 Long Range Express

The Shiloh Sharps 1874 Long Range Express is one of nine models of 1874 Shiloh Sharps rifles offered by the company. Every model can be customized individually, in numerous calibers, four grades of wood, multiple wood finishes, barrel length, weight and features—every minor detail and accessory a gun owner could want or imagine.

ShilohRifle.com

READERS' CHOICE:

**Uberti's 1885 High Wall Rifle
Accokeek, MD**



61 Sheezahnantan

In 1874, Timothy H. O'Sullivan paused from his landscape photography for the Wheeler Survey to take a series of portraits of Jicarilla Apaches, including Sheezahnantan, at the Abiquiu Agency near Tierra Amarilla, New Mexico Territory.

— COURTESY LIBRARY OF CONGRESS —

John Bianchi's
FRONTIER GUNLEATHER
STARQUEST INC.

50 Years Of Excellence In Gunleather

Free Color Catalog For True West Readers

1-760-324-6198
www.frontiergunleather.com

"The Standard by Which All Gunleather Is Judged"

HOTEL COLORADO
1893

GLENWOOD'S LEGEND

WINTER SPLASH & CRASH
FROM \$120*

*Some restrictions apply

The Hotel Colorado
Glenwood Springs, CO
(970) 945-6511
HotelColorado.com

BEST "WHO SLEPT HERE"
TRUE WEST
BEST WEST
TWO THOUSAND SIXTEEN



62 Party Photo

The Wheeler Expedition paused and resupplied at Fort Whipple near Prescott, Arizona Territory, in the fall of 1871, before following the Crook Trail to Camp Apache in the White Mountains.

— COURTESY LIBRARY OF CONGRESS —

BEST COMMEMORATIVE RIFLE

Navy Arms' 1873 Winchester Martinsburg, WV

To celebrate its first century of excellence, the Buffalo Bill Center of the West is proud to partner with Navy Arms and

Winchester Firearms to re-create the famed Winchester "Centennial Model" 1873 lever-action rifle. Working with Winchester, Navy Arms—the company that launched the replica-firearms industry—worked with original maker Winchester for the production of just 200 exhibition models and 1,000 presentation models. One hundred percent

of the profits from the sale of these two models will go to the mission of the Buffalo Bill Center of the West and the Cody Firearms Museum.

CodyGun.com/NavyArms.com

READERS' CHOICE:
Navy Arms' 1873 Winchester Martinsburg, WV

BOB BOZE BELL BOOKS BIG BOOK SALE

ILLUSTRATED LIFE & TIMES SERIES

"Factual, lively, and irreverent... History as it should be presented."

-Garry James, Guns & Ammo

~~\$39.95~~ Each

ON SALE NOW!

\$29.95 +S&H (each)

(Hard cover only)

ORDER YOURS TODAY!

Visit: Store.TrueWestMagazine.com

Call: 1-888-687-1881

TRUE WEST

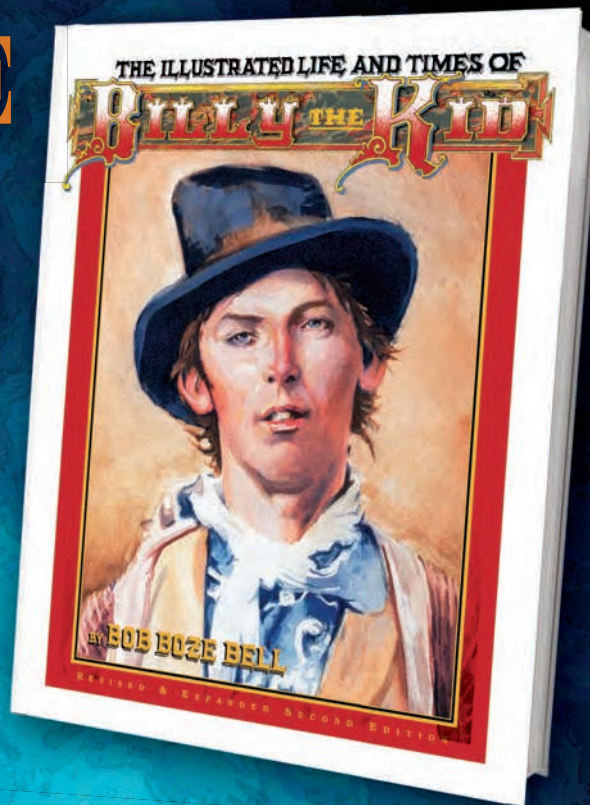
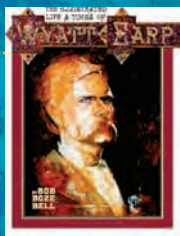

FIREARMS

63 Yellowstone

Hayden Survey photographer William Henry Jackson's landscapes of the Yellowstone country, including an encampment by a small lake between East Fork and Yellowstone Lake, helped influence President Ulysses S. Grant to create Yellowstone National Park.

— COURTESY YELLOWSTONE NATIONAL PARK —



All Aboard!

The Far-Famed Georgetown Loop Historic Mining & Railroad Park

A partnership of



and
Historic Rail
Adventures



A TRAIN FOR ALL SEASONS AND OCCASIONS

www.GeorgetownLoopRR.com

888-456-6777

WESTERN MOVIES

DVDs & TV SHOWS



BY HENRY C. PARKE



64 Feeling Small

The story of the dangers faced by John Wesley Powell and nine others while making a map of the Colorado River region during their 1869 expedition hit the big screen in 1960's *Ten Who Dared*. Shown above is Powell's assistant topographer, Frederick Samuel Dellenbaugh, on Powell's second expedition from 1871-72, seated by the Green River in Lodore Canyon.

— POWELL EXPEDITION PHOTO COURTESY U.S. NATIONAL PARK SERVICE; *TEN WHO DARED* POSTER COURTESY WALT DISNEY PRODUCTIONS —



The Pathfinder Films

For all of the pathfinders' importance in the settling of the West, the films about those great pioneers comprise a short list indeed. The best treatment of John C. "Pathfinder" Frémont is Richard Chamberlain's star portrayal in the 1986 miniseries *Dream West* (Warner Archive), which also featured Rip Torn as Fremont's frequent collaborator, Kit Carson.

Dana Andrews played Frémont as a supporting character in 1940's *Kit Carson* (United Artists), with Jon Hall in the lead. *Brady Bunch* dad Robert Reed played Frémont in Disney's 1977 *Kit Carson and the Mountain Men*, and Frémont turned up as a character once more in a 1966 episode of *Death Valley Days*, played by *Sergeant Preston of the Yukon* star Dick Simmons.

Not all of the films hit their mark. For instance, the title for *The Adventures of Frontier Fremont*, starring Dan Haggerty, suggested the 1976 movie would focus on the Pathfinder, but it played more like *Grizzly Adams 2*.

One worthy entry in the Lewis and Clark filmography is 1955's *The Far Horizons* (Warner Archive), starring Fred MacMurray as Meriwether Lewis, Charlton Heston as William Clark and Oscar winner Donna Reed as Sacagawea. The history is iffy, but the production is grand.

Otherwise, aside from a 1967 episode of *Death Valley Days*, in which Dick Simmons played Lewis to Don Matheson's Clark and Victoria Vetri's Sacagawea, Thomas Jefferson's explorers have had little screen time. In 2005, HBO and National Geographic announced



Thomas Jefferson's Corps of Discovery has been a work in progress for HBO and National Geographic since 2005. While you anticipate the release of that miniseries, in 2018, you can check out a musical adventure, called *Manifest Destiny*, that showcases the classic characters, Sacagawea, Meriwether Lewis and William Clark—and hand puppets.

— COURTESY NEW RENAISSANCE PICTURES —

remake of *The Magnificent Seven*, which, despite a strong cast that included Denzel Washington and Ethan Hawke, was deficient in every category aside from action.

While 2016 didn't end with the splash of the previous year, due to twin Christmas Day premieres for *The Hateful Eight* and *The Revenant*, it did close with an ever-growing schedule of quality Western film and TV releases that reassures us that the genre is a growing concern, not an endangered species.

■ BEST WESTERN MOVIE *Hell or High Water*

With a timeless story of the conflict between desperation-fueled criminality and the relentless forces of justice, *Hell or High Water* (CBS Films) is our pick. It deserves

an Academy Awards sweep, with four Oscar-worthy performances—by Jeff Bridges, Ben Foster, Chris Pine and Gil Birmingham—and equally fine writing, direction and cinematography.

READERS' CHOICE: *Traded* (Status Media)

■ BEST TRADITIONAL WESTERN MOVIE

Jane Got a Gun / Forsaken

A tie! That either film saw the light of day at all was a miracle resulting from stalwart filmmakers determined to get these excellent Westerns in front of audiences. *Jane Got a Gun* (The Weinstein Company), starring and produced by Natalie Portman, tells the story of a wife who must protect her husband from his former gang, with the help of her former lover. Nothing stopped this film; not the director quitting the first day of shooting, not star actors bailing along the way and, on the eve of release, not the original distributor filing for bankruptcy.

Facing its own challenges, *Forsaken* (Momentum) was shelved for two years due

a miniseries based on Stephen Ambrose's enthralling history of the expedition, *Undaunted Courage*, starring Edward Norton and Brad Pitt. Eleven years later, the project is set for a 2018 release, now starring Casey Affleck and Matthias Schoenaerts. The slow-poke filmmakers were beaten to the punch in 2016, with the release of *Manifest Destiny: The Lewis & Clark Musical Adventure*, a musical featuring Muppet-ish hand puppets as well as human performers.

Probably the best film about pathfinders is 1960's *Ten Who Dared* (Disney). James Drury, who played Walter Powell, tells *True West*, "It was the story of the first party of white men who went down through the Colorado River rapids after the Civil War. It was led by Captain [John Wesley] Powell, a surveyor and explorer who had been a major in the Union Army, and had lost an arm. They named Lake Powell after [him]. I don't think the picture made 10¢ for Disney, but it was just such a delightful show to be a part of."

The year 2016 truly was a big year for pathfinder films, although for a different path—the path to freedom (see sidebar).

The year was not so great, however, for traditional big-screen Westerns. *Diablo* (Orion/MGM), starring Clint Eastwood's son, Scott, made some waves, as did *Traded* (Status Media), starring Michael Paré; both films garnered less attention than they deserved and are worth seeing. The most notable disappointment was the Sony



The epic, true story of some of the most wanted men in Australia's bushranger history is showcased in *The Legend of Ben Hall*.

— BY KIM DICKSON —

WESTERN MOVIES

DVDs & TV SHOWS



Known as *Dominion Creek* when streaming in the U.S. on Netflix, the Irish Western television series, *An Klondike*, follows emigrant brothers who travel from Montana to the Canadian Yukon during the Klondike Gold Rush.

— COURTESY ACORN —

to financial problems. But the story of an estranged soldier son and minister father—played by real-life son and father Kiefer and Donald Sutherland—who joined forces to protect their town, gave a fresh and moving spin to some familiar themes.

READERS' CHOICE:
Diablo (Orion/MGM)

BEST FOREIGN WESTERN MOVIE

The Legend of Ben Hall

The true story of Australia's Jesse James, *The Legend of Ben Hall* (Pinnacle Films) is handsomely written and directed by Matthew Holmes and stars Hall's dead ringer, Jack Martin. With solid performances throughout, the film tells the story of an outlaw trying to end his criminal career, humanizing him and his gang without whitewashing them. It's exciting, romantic, beautiful, packed with action, yet full of



**EARLY & MODERN
FIREARMS COMPANY, INC.**



F.LLI PIETTA

Experience, Quality, and Customer Service Unsurpassed!

**"The BEST in Cowboy Guns"
since 1956!**

DELUXE "CALIFORNIAN"



AVAILABLE:
.357Mag, 45LC
4¾" Barrel Only
One Piece Checkered Walnut Grip
MSRP \$545 **Sale \$485**

*** HISTORICALLY CORRECT REPLICAS!
* NO TRANSFER BARS!**

TRADITIONAL "CALIFORNIAN"



AVAILABLE:
.357Mag, 45LC
4¾" Barrel Only
One Piece Ultra Ivory Grip
MSRP \$560 **Sale \$499**

AVAILABLE:
.357Mag, 44/40, 45LC
4¾", 5½", 7½"
One Piece Walnut Grip
MSRP \$530 **Sale \$475**

WWW.EMF-COMPANY.COM (800) 430-1310



regret, betrayal and the sense of mistakes that cannot be undone.

READERS' CHOICE:
Brimstone (Embankment)

BEST TV WESTERN

Westworld

We regretfully had to bid farewell to AMC's *Hell on Wheels*, a consistently excellent series that did so much to stimulate the revival of the Western. But at least the show finished the Transcontinental Railroad before leaving. Netflix kept *Longmire* fans happy by streaming a fifth season, a fine release. The wonderful surprise of the year, and the Best TV Western, is the HBO miniseries *Westworld*, which took an already wonderfully clever 1973 movie and re-imagined it with even more depth, soul and humor.

READERS' CHOICE:
Hell on Wheels (AMC)



Natalie Portman and father-and-son Sutherlands bring star power to two Westerns that almost did not get made, but thankfully did. Both films should please fans seeking American Westerns that adhere to traditional story tropes.

— FORSAKEN POSTER COURTESY MOMENTUM; JANE GOT A GUN POSTER COURTESY THE WEINSTEIN COMPANY —

TOMBSTONE

Art by Jerry Crandall

Celebrating the iconic western movie **TOMBSTONE**, Jerry Crandall has gathered relevant collector items significant to the movie. Jerry was a Cowboy in the film and appears in the print where he was shot off his terrific movie horse Apache, during which he broke his shoulder!

The notable Curly Bill boots are prominent with their recognizable Aces hand of cards. O.K. Corral sign, the flat brimmed hat and rumbled famed red sash are movie reminders.

Propped on a leather Wyatt Earp trunk is a small green card case against which is leaning the fabled Buntline Special which was used by Wyatt Earp in the movie.



Original oil 34" X 30"
 Canvas Giclée 24" X 21" \$225.
 Art Print 22" X 20" \$65.



www.eagle-editions.com * oldwest@eagle-editions.com * 1-800-255-1830

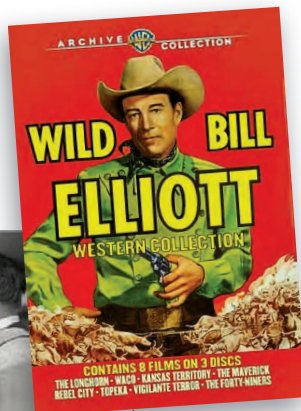

Wild Bill Elliott stars as the peaceable sheriff (above, far left) in 1953's *Vigilante Terror*, a B-Western far tougher than earlier films—the tense hanging scene makes the law of the rope appear barbaric, and one of the gang members gets shot in the face!

— COURTESY ALLIED ARTISTS / WARNER ARCHIVE —



Rod Serling first made a commentary on the “soft” Westerns appearing on TV through “Showdown with Rance McGrew,” a *Twilight Zone* episode in which a Westerns actor (played by Larry Blyden, above) encounters the ghost of Jesse James. Serling convinced CBS to air a realistic Western, *The Loner*, starring Lloyd Bridges (inset), but the creator was ahead of his time. The show lasted less than one season, yet shines today on DVD.

— COURTESY CBS / SHOUT! FACTORY —

BEST FOREIGN TV WESTERN *Dominion Creek*

Dominion Creek (Acorn) is a delightful surprise from the Broadcasting Authority of Ireland. The three Connolly brothers, sorely disappointed with Montana’s silver mines, accept the gift of a friend’s claim and head for the Yukon—and a world of danger and adventure. The series remarkably captures the sense of the Irish community within the Gold Rush by having much of the dialogue in subtitled Gaelige.

BEST WESTERN MOVIE BLU-RAY

The Ox-Bow Incident

The best of the many fine classic Western DVD releases of the year is Kino Lorber’s edition of 1943’s *The Ox-Bow Incident*, which tells the story of a lynching and its heartbreaking repercussions. One of Henry Fonda’s best Westerns, featuring an exceptional cast that includes Dana Andrews and Anthony Quinn, this edition offers wonderful narration by the son of director William Wellman.

READERS’ CHOICE: *Man in the Wilderness* (Warner Archive)

BEST WESTERN MOVIE COLLECTION

Wild Bill Elliott Western Collection

Warner Archive brings viewers the always-engaging presence of William Elliott, in the final films of his sagebrush career, in the *Wild Bill Elliott Western Collection*. The first film, 1951’s *The Longhorn*, is a traditional Monogram B-Western; by the eighth film, 1954’s *The Forty-Niners*, Monogram had reinvented itself as Allied Artists and, even with Elliott maintaining his butt-forward pistols, the story plays like *Dagnet*, including a Jack Webb-style narration.

READERS’ CHOICE: *George O’Brien Western Collection* (Warner Archive)

WESTERN MOVIES

DVDs & TV SHOWS



Although the 1943 Western failed to pay its way and may be considered a box-office flop, *The Ox-Bow Incident*, starring Henry Fonda, earned enough accolades to land at the Academy Awards. The Western lost the Oscar for Best Picture to *Casablanca*.

— COURTESY TWENTIETH CENTURY-FOX FILM / KINO LORBER —

BEST SILENT WESTERN RELEASE

3 Bad Men

John Ford directed *3 Bad Men* (Kino Lorber), a stunning variation on *The Three Godfathers* story, with the 1926 Western featuring a trio who protect an orphaned teenage girl (Olive Borden). In this moving and complex story, the 1877 Dakota Territory land rush sequence is the most enthralling scene of its kind ever filmed.

READERS' CHOICE: Another Man's Boots (Grapevine Video)

BEST FILM FESTIVAL

Lone Pine Film Festival

California's Lone Pine Film Festival takes place in the magical landscape of the High Sierras, around the fabled Alabama Hills, which have been featured in Western classics since the days of silent cinema. Last year's theme focused on *3 Bad Men* and *3 Godfathers*. It was a second- and third-generation family affair, featuring John Ford's grandson Dan, William Wellman's son William Jr., William Witney's son Jay Dee Witney, Robert Mitchum's daughter Petrine Day Mitchum, Roy Rogers' and Dale Evans' daughter Cheryl Rogers Barnett, Harry Carey Jr.'s daughter Melinda Carey and Joel McCrea's and Frances Dee's grandson Wyatt McCrea.



Henry C. Parke is a screenwriter based in Los Angeles, California, who blogs about Western movies, TV, radio and print news: HenrysWesternRoundup.Blogspot.com



Free State of Jones

— COURTESY UNIVERSAL / SHOWTIME NETWORKS —

PATH TO FREEDOM

Of all the heroic journeys that Western film and TV examined in 2016 the most frequent was the trek to escape slavery.

Alex Haley's discovery of his African ancestor's roots in slavery, told in the novel *Roots*, inspired the groundbreaking 1977 miniseries (Warner Archive). Nearly four decades later, a new *Roots* (Lionsgate) retold Kunta Kinte's abduction, sale into slavery and eventual triumph. Airing on the History Channel, A&E and Lifetime, the miniseries was grittier and stunningly photographed. Malachi Kirby was impressive as Kinte, though, at 26, compared to LeVar Burton's age of 19 in the original, he was more of a man than the boy becoming a man.

WGN America aired its original drama, Sony's *Underground*, that shared a compelling story of the Underground Railroad's anti-slave forces and slaves trying to escape bondage. *Underground*, like the *Roots* remake, featured a largely unfamiliar, but talented and convincing cast. Full of surprising turns, this wise tale has been renewed for a second season.

The status of blacks, both slave and free, was a major element in the Civil War medical drama *Mercy Street* (PBS) about two nurses from opposite sides of the war. The Ridley Scott-produced series has been renewed for a second battle.

Slavery hit the big screen too. *The Birth of a Nation* (Fox Searchlight) focused on Nat Turner's slave revolt in the antebellum South, while *Free State of Jones* (Universal), based on the true story of whites and blacks who tried to secede from the Confederate States to form a free country, should have been a hit, but the excessive speechifying undercut the powerful action and story.

BEST TV DVD

The Loner

When *Twilight Zone* ended, writer Rod Serling followed the Psychological Thriller with a Western series, *The Loner* (Shout! Factory), in which he transferred some of his own post-WWII angst into the post-Civil War era. Lloyd Bridges stars as William Colton, a former Union Army captain, who, six months after the end of the war, is a drifter colliding with people whose pain is still as raw as his own. Today, we would say he had PTSD. Just about every top TV actor of the era appeared in the series, which aired from 1965-66, including Burgess Meredith, Tony Bill, James Whitmore, Katharine Ross, Victor Jory and Bridges' sons Beau and Jeff. Many, like Lloyd Bridges, did some of their best work on this fascinating series.

READERS' CHOICE:

Daniel Boone: Season One
(Shout! Factory)

BOB BOZE BELL BOOKS

BIG BOOK SALE

CLASSIC GUNFIGHTS V. I, II & III

“Factual, lively,
and irreverent...
History as it should
be presented.”

-Garry James, Guns & Ammo

~~\$29.95~~ Each

ON SALE NOW!

\$19.95 +S&H (each)

(Soft cover only)

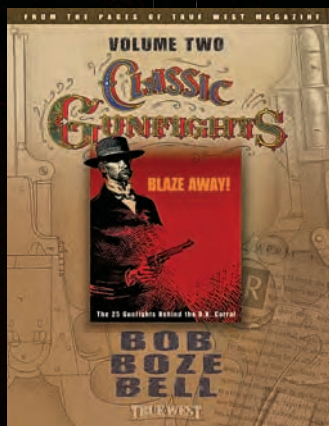
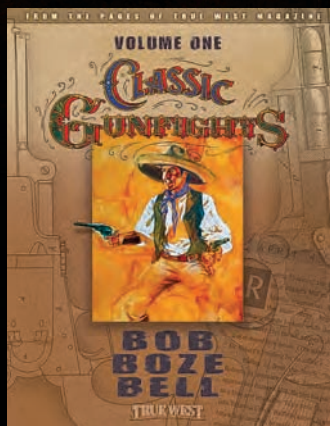
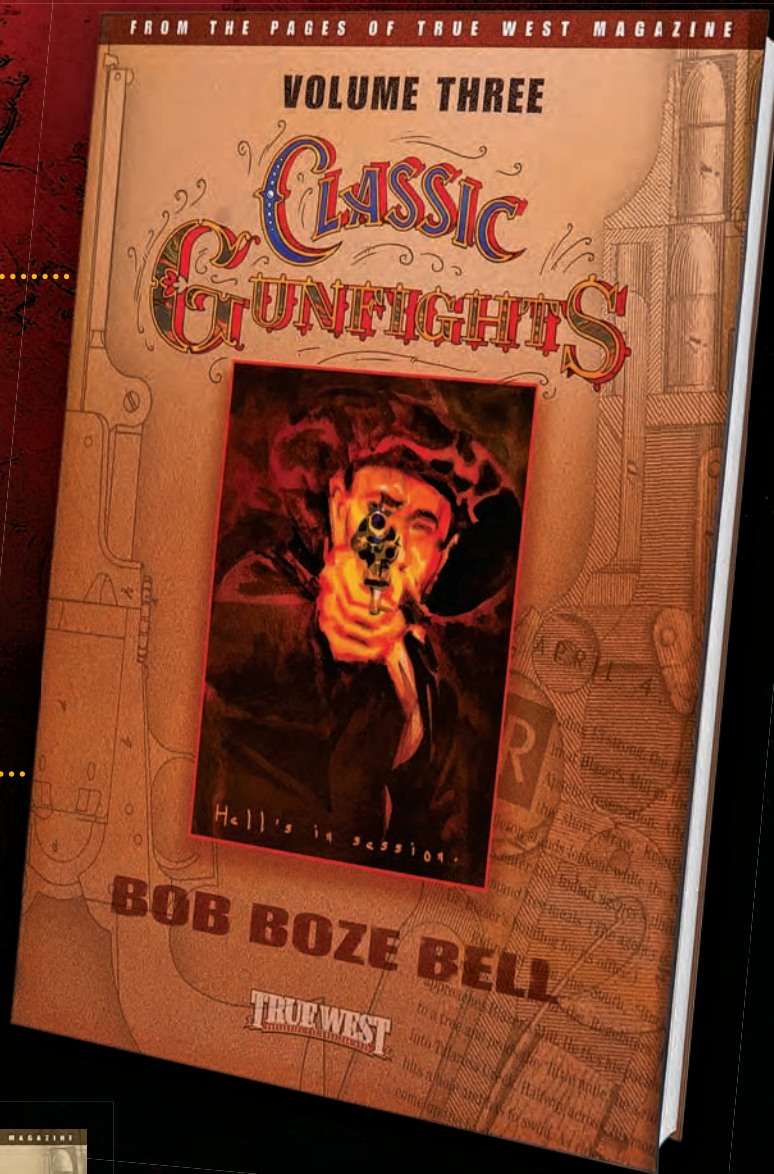

ORDER YOURS TODAY!

Visit: Store.TrueWestMagazine.com

Call: 1-888-687-1881

TRUE WEST
HISTORY OF THE AMERICAN FRONTIER

WESTERN WEAR

BY MEGHAN SAAR

Style and Science

How two budding geologists entered the field thanks to a keen eye for fashion.

Fashion was the element that brought two Yale buddies into the circle of the U.S. Geological Survey.

James Terry Gardiner and Clarence King had made their way west to California and, on September 20, 1863, they experienced a chance encounter in Sacramento that changed the course of their lives forever.

Gardiner described their good fortune in a letter to his mother: “[The steamship] was crowded with people from the mines. Many rough, sunburned men in flannel shirts, high boots, belts, and revolvers were around me, but among them one man attracted my attention.... An old felt hat, a quick eye, a sunburned face with different lines from the other mountaineers, a long weather-beaten neck protruding from a coarse gray flannel shirt and a rough coat, a heavy revolver belt, and long legs, made up the man; and yet he is an intellectual man—I know it...I went to Clare [King], told him the case, and showed him the man. He looked at him, and, without any previous knowledge to guide him in the identification, said, from instinct, ‘That man must be Professor Brewer, leader of Professor Whitney’s geological field-party.’”

King had guessed correctly. After dinner that evening, he introduced himself and his pal to the man. The next day, Brewer introduced them to Whitney’s men. Within a week, Gardiner and King were part of the team for the California Geological Survey.



65 Stylish Scientists

The California Geological Survey spurred the creation of the federal government’s U.S. Geological Survey. Josiah D. Whitney chose William H. Brewer as chief botanist to lead the California team. In the 1864 field party photograph, one member, Charles Hoffman, is absent. (From left) James T. Gardiner, Richard D. Cotter, William H. Brewer and Clarence King.

— COURTESY NATIONAL PORTRAIT GALLERY, SMITHSONIAN INSTITUTION —

WESTERN WEAR



66 Gardiner's Hair of Gold

In 1873, Anna Dickinson climbed Longs Peak in Colorado Territory with Ferdinand V. Hayden's survey. When she had tea with survey member James T. Gardiner (seated first on the right) in Denver later that year, he had cut his "long waving locks" and "tawny beard." When he appeared next to her, "... close cropped, white shirted and clad in Widenfeld's best cut," he wrote, "she bemoaned...the loss of...my beautiful golden hair."

— COURTESY USGS —

Four years later, at the age of 25, King was the leading geologist for the 40th Parallel survey. He was quite an icon of fashion, noted Henry Adams, the grandson and great-grandson of two U.S. Presidents. "In the evening, after a long, gritty day in the field, he donned silk hose, gleaming shoes, and a suit freshly pressed by his valet." When Adams saw King in his finery by the campfire, he described him as "a bird of paradise rising in the sage-brush."

If anyone dared to tease the geologist about his fancy clothing, they got a lecture: "It is all very well for you, who lead a civilized life nine

or ten months in the year, and only get into the field for a few weeks at a time, to let yourself down to the pioneer level.... But I, who have been for years constantly in the field, would have lost my good habits altogether if I had not taken every possible opportunity to practice them."

King was truly a scientist with style.

BEST WESTERN CLOTHING STORE

Texas Jack Wild West Outfitter, Fredericksburg, TX

Named for the Comanche fighter and consummate plainsman John "Texas Jack" Omohundro, the Texas Jack store pays homage to this valiant cowboy as an Old West outfitter selling 1870s cowboy gear and apparel, approved authentic by members of cowboy action and single action shooting groups. Housed in a former 1889 livery stable, Texas Jack Wild West Outfitter bleeds the frontier West in every pullover shirt, paisley vest frock coat and pair of saddle pants.

TexasJacks.com

READERS' CHOICE:
Miller Ranch, Denver, CO



67 Camp Clothes

Ferdinand V. Hayden's survey crew relaxes in their camp clothes in this 1872 photo by William Henry Jackson.

— COURTESY YELLOWSTONE NATIONAL PARK —

68 In Paiute Country

Somewhere in the Four Corners region, in 1873 or 1874, artist Thomas Moran (middle) and photographer William Henry Jackson (right) sit dressed in their field work garb next to the brightly costumed and feathered Paiute child.

— TRUE WEST ARCHIVES —

BEST WESTERN HAT MAKER

Catalena Hatters, Bryan, TX

Made the old-fashioned way, by hand, one at a time, the custom felt hats crafted by Catalena Hatters are the best in the world for a cowboy hat connoisseur. The Catalena family can even help you restore a damaged cowboy hat that just may be too sentimental for you to discard. They are true lovers of the cowboy hat, and their pride and attention to detail show through in each hat they custom shape for their customers.

CatalenaHats.com

READERS' CHOICE:
Bronco Sue Custom Hats, Ruidoso, NM



69, 70 Frontier Indians

John K. Hillers produced some of the earliest views of American Indians (top photo, from the 1873 Powell Expedition), while Edward S. Curtis photographed tribes closer to the turn of the 20th century; the above portrait shows Haschezhini, a Navajo wearing a dark leather mask and a fur ruff.

-COURTESY LIBRARY OF CONGRESS -



71 Dapper Explorer

Looking dapper, James Stevenson was the able assistant to Ferdinand V. Hayden ever since accompanying him to the Dakota Badlands in 1866.

- TRUE WEST ARCHIVES -

CATALENA HATTERS
*Fits Right.
 Looks Right.
 Feels Right*

The Gus

Telescope

800-976-7818
www.catalenahats.com

SUPERSTITION MOUNTAIN MUSEUM

Discover
HISTORY & MYSTERY

PLAN TO ATTEND
**HERITAGE DAYS
 JAN. 14 & 15, 2017**

480-983-4888
 4087 N. Apache Trail (Hwy. 88) Apache Junction, AZ 85119
www.superstitionmountainmuseum.org

MILLER RANCH
 EST. 1918
Ranch.
 BY **CINCH**

**THANK YOU
 FOR VOTING
 MILLER RANCH
 "BEST WESTERN
 CLOTHING MAKER!"**

MILLERRANCH1918.COM



PHOTOGRAPH BY THE U.S. GEOLOGICAL SURVEY, FIRE HOLE BASIN

72 Pre-Yellowstone Settlers

During the exploration survey that would inspire the creation of Yellowstone National Park, William Henry Jackson photographed these Pease Ranch cowboys, living along Yellowstone River.

- COURTESY YELLOWSTONE NATIONAL PARK -



74 Chinese Miners

These Chinese miners were among the immigrants who sought their fortunes and spread their culture in the Western frontier, shown sluicing for gold in this 1871 photograph by William Henry Jackson.

- COURTESY LIBRARY OF CONGRESS -

WESTERN WEAR

73 Flanked Near Firehole Basin

Wearing everyday field work clothing, Hayden survey members lined up for William Henry Jackson to take this 1872 photo (opposite page) near Firehole Basin in the Yellowstone environs of Wyoming Territory.

- COURTESY YELLOWSTONE NATIONAL PARK -

BEST WESTERN BOOTMAKER

Lucchese Boots, El Paso, TX

The Texas frontier troops at Fort Sam Houston must have been thrilled when the Lucchese brothers opened their boot shop in San Antonio in 1883. They made their boots affordable, yet of high quality, which holds true to this day. Their dependable boots range in style from heirloom to roper to Western, suitable for a dressy formal affair or a casual night on the town.

Lucchese.com

READERS' CHOICE:

Corral Boots, El Paso, TX

BEST PERIOD WESTERN CLOTHING MAKER

Classic Old West Styles, El Paso, TX

Folks looking for handmade Western clothing and work wear made in the good old U.S.A. need look no further. You can find classic Old West styles of coats, vests, jackets, dusters, shirts and pants to your heart's content. These vintage looks are the go-to preference for movie stars to ranch hands.

COWS.com

READERS' CHOICE:

Recollections, Hawks, MI



★ **2 Acre "Wholesale Only" Showroom** ★ **Estab. 1970** ★

STORES & DEALERS NEEDED

★ **FREE Wholesale Catalog** ★

www.ElPasoSaddleblanket.com

6935 Commerce Ave • El Paso, TX 79915 • 1.800.351.7847

Fine Imported Indian & Mexican Weavings • Rugs • Blankets • Serapes • Bedspreads • Mats

GOLDEN GATE WESTERN WEAR

Old west and contemporary hats, apparel, boots, and accessories for the whole family. Our custom hats are hand-formed by Bill Knudsen-**Reader's Choice Best Hatmaker** four years in a row! Can't wait? We have **quick-ship** stock hats too.

R. Crowe
3:10 To
Yuma

The Good,
The Bad,
& The Ugly

See our online catalog at
www.KnudsenHats.com
ORDERS: (510) 232-3644

The Best Old West Eyewear

"Reproduction 1800's spectacles to suit all sights"

Historic EyeWear Company
Keeping History in Sight®

HistoricEyeWearCompany.com
862.812.4737

HERITAGE TRAVEL

BY STUART ROSEBROOK

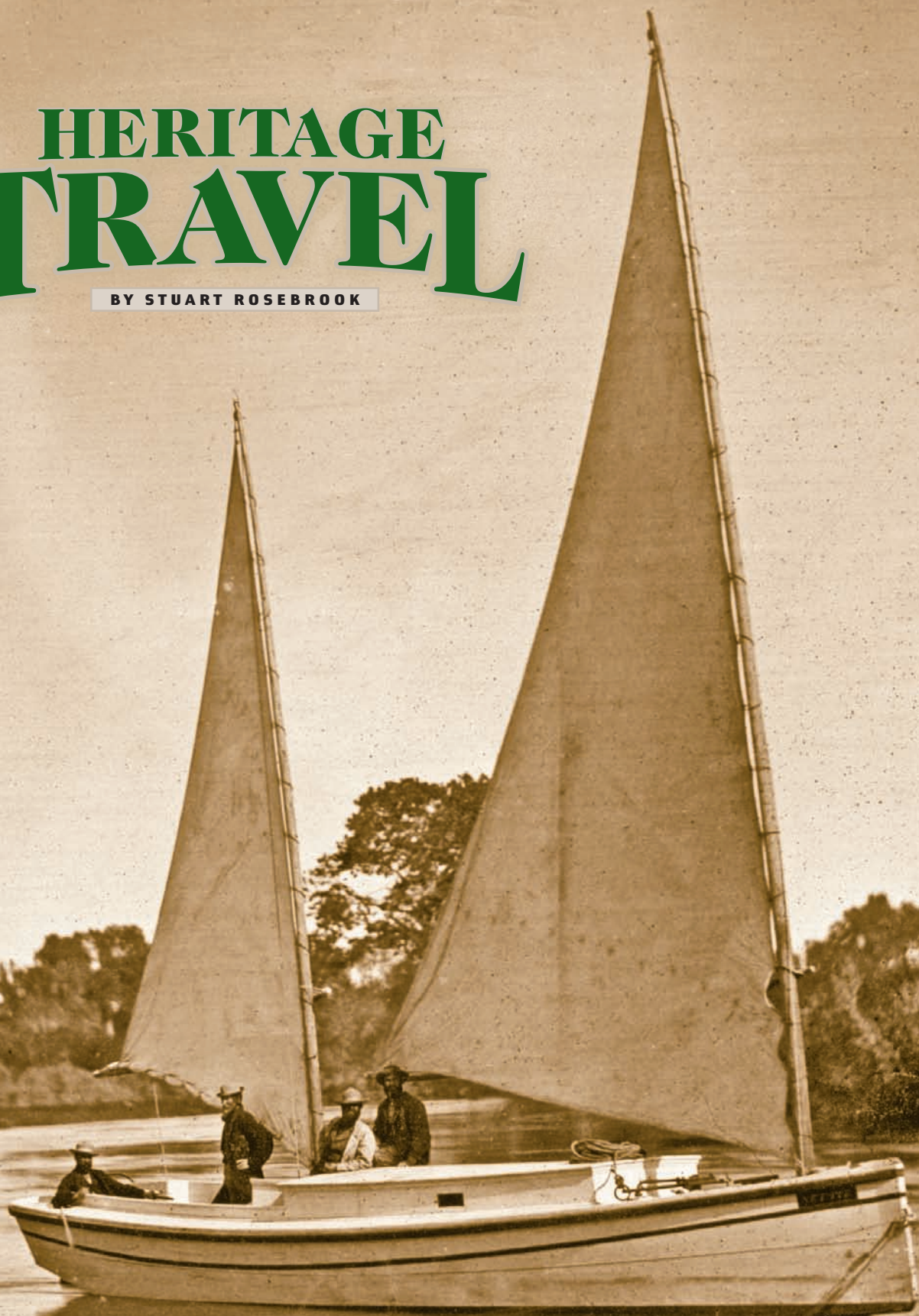



75 Timothy H. O'Sullivan on the Truckee River

In 1867, photographer Timothy H. O'Sullivan accompanied the Clarence King Survey of the 40th Parallel, which set up its base camp near the Truckee River and Reno, Nevada. Sullivan's adventuresome spirit as a photographer put him in position to capture many unique images with his large-format glass-plate camera, including the survey team sailing on the Truckee River.

COURTESY LIBRARY OF CONGRESS

Grand Adventures Await the Western Traveler

Millions of miles of interstates, highways, roads and dirt tracks crisscross the mountains, valleys, deserts and plains of the Western United States. Amtrak still delivers passengers across the West, and dozens of heritage railroads have preserved and restored historic lines for modern rail enthusiasts. On the major waterways and lakes, travelers can cruise on modern paddle-wheelers, schooners, ships, ferries and houseboats.

High adventure awaits across the West at guest ranches, where wranglers will lead you on horseback into the mountains or on a real cattle drive; on rivers, where rafting companies will take you deep into red walled river canyons or canoe- and kayak-outfitters will take you deep into the woods to experience life like a French voyageur.

After after sleeping under the stars, head into town and you will discover that historic hotels, inns and restaurants are the staple of Western towns. Equally, the traveler who loves big Western cities will discover hotels with history, and the fine meals and accommodations that make them even more enjoyable than they were when they hosted the rich and famous 150 years ago. So whether you are bedding down in a bedroll after a chuck-wagon dinner and a chorus around the campfire, or enjoying the lights of a city from a restaurant atop a turn-of-the-last-century heritage hotel, Western proprietors await your visit—ready to help you plan your adventure and make memories of a lifetime.

—*Stuart Rosebrook*

Visit Chama

New Mexico
Your Year Round
Outdoor Fun and
Adventure Destination
Gateway to The Rocky Mountain
Continental Divide Trail



Come Play



In The Snow



Winter Sports In Chama



Stay in Chama, New Mexico
Fine Food & Lodging
Chama Chile Ski Classic
XC Race In January
Martin Luther King Jr. Weekend

(800) 477-0149

(575) 756-2306

info@chamavalley.com

chamatw.com



Funding Provided by the Village of Chama Lodgers Tax

HERITAGE TRAVEL



76 Grand Cañon of the Colorado

When Timothy H. O'Sullivan was not available for Lt. George H. Wheeler's survey in 1872, he hired William H. Bell. The Philadelphia photographer had a keen eye for nature's artistry, and is well known for his vertical compositions with great depth of field.

— COURTESY LIBRARY OF CONGRESS —

BEST PLACE TO LIVE LIKE AN OLD WEST COWBOY (Winter)

Prescott, AZ

The original territorial capital of Arizona, Prescott has history and heritage honored and celebrated throughout the year at numerous local museums, hotels and restaurants. Don't miss Frontier Days and the World's Oldest Rodeo every Fourth of July.

Visit-Prescott.com

READERS' CHOICE:
Bandera, TX

BEST PLACE TO LIVE LIKE AN OLD WEST COWBOY (Summer)

Deadwood, SD

Founded in 1876 at the northern edge of South Dakota's Black Hills, Deadwood welcomes visitors all year long, but summertime in the historic town is a prime time to enjoy the heritage of one of the West's most famous destinations. The annual Days of '76 Parade and Rodeo in late July is one of the best events of the year.

Deadwood.com

READERS' CHOICE:
Sheridan, WY



TAKE A RIDE.

A fantastic line-up of events is just around the corner. Join us out Wickenburg way!

Wickenburg
LET'S RIDE

Wickenburg Chamber of Commerce
& Visitors Bureau
(928) 684-0977

VisitWickenburg.com
facebook.com/WickenburgAZ

2/10 - 2/12/17

Gold Rush Days

2/11/17

Gold Rush Days
Parade

2/11 - 2/12/17

Gold Rush Days
Senior Pro &
Open Stock Rodeo

4/22/17

Vintage
Market Place

5/6/17

Spring Dance &
Food Truck Night

9/2/17

Fiesta de Septiembre

10/8/17

Wickenburg
Fly-In & Classic
Car Show

11/10 - 11/12/17

Wickenburg
Bluegrass Festival

12/1 - 12/2/17

Cowboy Christmas
Poets Gathering

12/8/17

Christmas Parade
of Lights

77 Yosemite Valley

A student of California pioneer photographer Carleton E. Watkins, George Fiske worked with the famed artist known for his master works of Yosemite, before Fiske opened his own studio in Yosemite Valley in 1879. Like Watkins', many of Fiske's photos and negatives were lost to fire, but many regard his surviving Yosemite images as equally important, and as artistically important, as his tutor's.

— TRUE WEST ARCHIVES —



BEST OLD WEST GUNFIGHTER TOWN

Dodge City, KS

Take a trolley ride tour of Dodge City to discover the thrill of the Old West in the "Queen of the Cowtowns" at the Boot Hill Museum, Gunfighters Wax Museum, Trail of Fame, Home of Stone and Kansas Heritage Center. Every summer gunfighter re-enactors hold thrilling events along "Front Street" at the Boot Hill Museum.

VisitDodgeCity.org

READERS' CHOICE:
Tombstone, AZ

BEST PRESERVED PIONEER TOWN RE-CREATED

High Desert Museum, Bend, OR

Where can you find Old West living history events and a zoo all in the same fun place? At the High Desert Museum in Bend, Oregon, that's where, all on 135 acres, with indoor and outdoor exhibits.

HighDesertMuseum.org

READERS' CHOICE:
Dodge City, KS

BEST OLD WEST ART TOWN

Cody, WY

From galleries to museums, Cody, Wyoming, is a Western art lovers dream come true. Start at the Buffalo Bill Center of the West's Whitney Western Art Museum, then head downtown to tour and shop at the art galleries, saddle shops and Western artisan stores. Don't miss the month-long Buffalo Bill Art Show & Sale every August and September, and the Rendezvous Royale Western art celebration the fourth week of every September.

CodyChamber.org

READERS' CHOICE:
Scottsdale, AZ

BEST TOWN FOR HISTORIC ENTERTAINMENT

Deadwood, SD

Put on your boots and hat and walk on down Deadwood's Main Street and enjoy famous restaurants, museums, saloons, shops and haunted hotel tours at the Historic Bullock Hotel and the Historic Fairmont Hotel and Oyster Bay Bar. In the summer, don't miss the *Trial of Jack McCall* drama six nights a week, the Deadwood Alive's Main Street Shows and Shootouts.

Deadwood.com

READERS' CHOICE:
Tombstone, AZ

PENDLETON ROUND-UP™



and HAPPY CANYON



"LET'ER BUCK!"

SEPTEMBER
13-16
2017
PENDLETON, OR

*the Epic
Drama
of the
West*

BUY TICKETS AT
pendletonroundup.com

SHOP ONLINE: leterbuck.com

ATTENTION READERS!

To receive FREE information from our advertisers, simply make your selections from the category listing on the adjacent card. Either mail the post-paid card or fax it to 480-575-1903. We will forward your request. Valid until 01/31/17.

ADVENTURE

- Cumbres & Toltec Scenic Railroad p. 13
Durango & Silverton Narrow Gauge Railroad p. 65
Garrett Metal Detectors p. 17
Georgetown Loop Railroad p. 79
Kansas Cattle Towns p. 107
O.K. Corral p. 1

APPAREL & ACCESSORIES

- Catalena Hatters p. 89
Classic Old West Styles p. 74
Fort Brands Western Wear BC
Golden Gate Western Wear/ Knudsen Hat Co. p. 91
Historic Eyewear Company p. 91
Miller Ranch p. 89

ART & COLLECTIBLES

- Brian Lebel's Western Americana Show & Auction p. 3
Burley Auction Gallery p. 53
Cowboy Legacy Gallery p. 2
Eagle Editions p. 83
Heritage Auction Galleries p. 69
John Wayne Masterpiece Sculpture p. 15
Maze Creek Studio/AndyThomas Art IBC
Sherry Blanchard Stuart p. 55

EVENTS

- Americana, Political & Legends of the West Auction p. 69
Brian Lebel's Western Americana Show & Auction p. 3
Cochise Cowboy Poetry Gathering p. 123
Cowgirl Up! Show & Sale p. 55
Dave Stamey/Concerts & DVDs p. 61
Estate Auction, Texas Ranger Collection p. 53
Hells Canyon Mule Days p. 116
National Cowboy Symposium & Celebration p. 123
Pendleton Round-Up p. 96
Shootout On Whiskey Row p. 76
Superstition Heritage Days p. 89
The Artists of Taos Exhibition IFC
Wickenburg, AZ 2017 Events p. 95

FIREARMS & KNIVES

- Black Hills Ammunition p. 75
Buffalo Arms Co. p. 74
E.M.F. Company p. 82
Old West Reproductions p. 76
Taylor's & Company p. 70
The Hawken Shop p. 74

FOOD & BEVERAGE

- The Buckhorn Exchange p. 103

HOME

- El Paso Saddleblanket p. 91
Fort Brands Home Décor BC
True West Home p. 60

LODGING

- Buffalo Bill's Irma Hotel p. 111
Hotel Colorado p. 77
Talking Stick Resort p. 101
White Stallion Ranch p. 103

MEDIA

- Dave Stamey Entertainment p. 61
Guidon Books p. 61
The Last Wild Ride by Lee Martin p. 67

MUSEUMS

- Boot Hill Museum p. 62
Buffalo Bill Center of the West p. 73
Deming Luna Historical Society p. 98
Harold Warp Pioneer Village p. 108
John Wayne Birthplace & Museum p. 63
Knight Museum & Sandhills Center p. 117
Old Trail Town Museum p. 109
Panhandle-Plains Historical Museum p. 104
Placer County Museums p. 60
Stuhr Museum of the Prairie Pioneer p. 116
Superstition Mountain Museum p. 89
Western Spirit: Scottsdale's Museum of the West IFC

PRESERVATION

- Concordia Cemetery p. 105
Crow Canyon Archaeological Center p. 104
Kansas Cattle Towns p. 107

TOURISM

- Albany County/Laramie, WY p. 110
Bandera, TX p. 109
Big Bend National Park, TX p. 11
Buffalo, WY p. 113
Carbon County, WY p. 119
Cave Creek, AZ p. 100
Chama, NM p. 94
Cheyenne, WY p. 117
Cody, WY p. 63
Coffeyville, KS p. 107
Deadwood, SD p. 120
Dodge City, KS p. 107
Elko, NV p. 16
Florence, AZ p. 98
Kansas Cattle Towns p. 107
North Platte, NE p. 54
Ogallala, NE p. 105
Pendleton, OR p. 108
Russell, KS p. 107
Scott City, KS p. 107
ScottsBluff/Gering, NE p. 117
Sheridan, WY p. 115
Terlingua, TX p. 11
Wickenburg, AZ p. 95

OTHER

- Bob Boze Bell Books: Badmen p. 64
Big Book Sale: Classic Gunfights Series: Vol. I, II, III p. 86
The Illustrated Life & Times Series: Billy The Kid, Doc Holiday, Wyatt Earp p. 78
BobBozeBell.net: Daily Whipouts p. 54
True West Doc Holliday T-Shirts: I'm Your Huckleberry/ The Dr. Will See You Now p. 64
True West Special Subscription Offer with FREE Romaine Lowdermilk CD p.68

**Visit
Deming
Luna Mimbres
Museum!**

**301 S Silver
Deming NM
575-546-2382**

www.ExploreDeming.com

Not Just
A Place...
But A
Destination

**Deming is
NEW MEXICO True.**

VISIT FLORENCE, ARIZONA

32nd Annual
**Historic
Home Tour**

February 11, 2017
10:00 a.m. to
4:00 p.m.

*"Florence: Born of
Adobe Brick and the
Frontier Spirit"*

Tickets Available Online at
www.florenceaz.gov

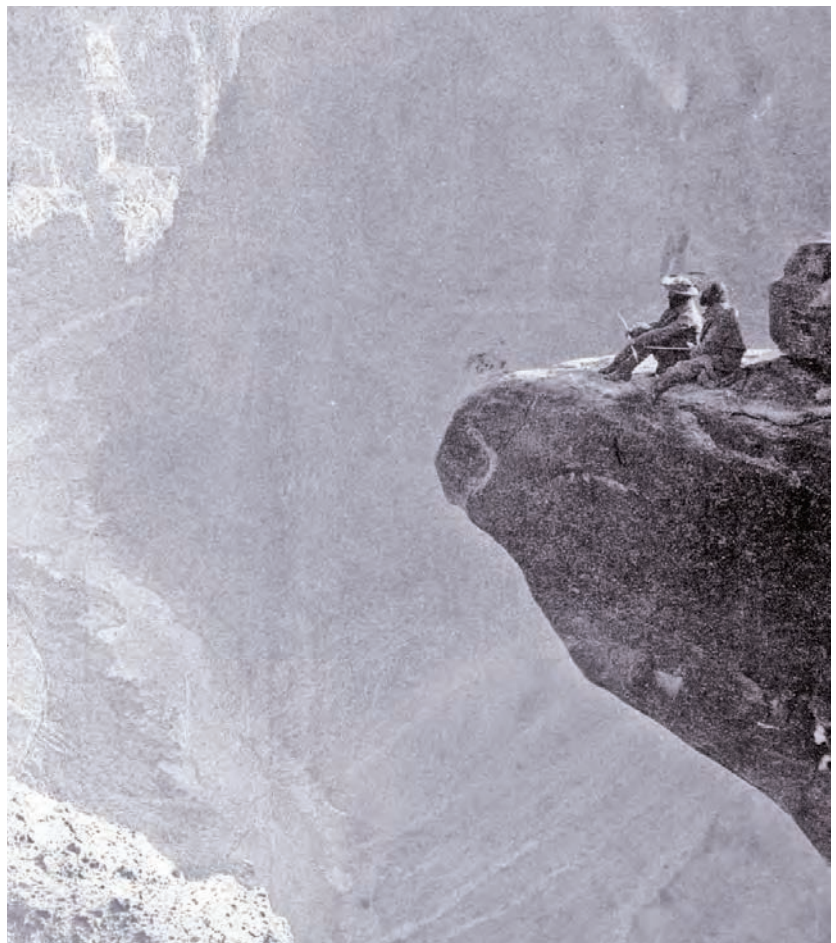

78 Devil's Anvil

In 1872, William Bell accompanied Lt. George M. Wheeler as photographer on the Corps of Engineers' Geographical Explorations and Surveys West of the 100th Meridian. One remarkable photo from the Colorado River series is of two surveyors sitting on Devil's Anvil overlooking Sheavwitz Crossing in the Grand Canyon.

- COURTESY LIBRARY OF CONGRESS -

BEST ARCHITECTURALLY PRESERVED WESTERN TOWN

Virginia City, MT

In 1863, gold was discovered along Alder Creek. The rush into the hills led to numerous claims and the founding of Virginia City, Montana. Once the territorial capital of Montana, the historic, living-history village invites visitors to stay and immerse themselves in the heritage community with its Old West entertainment, lodging, restaurants and activities, including stagecoach and train rides.

VirginiaCity.com

READERS' CHOICE:
Deadwood, SD

BEST HISTORIC TOWN TOUR

Laramie, WY

Best known today as the home of the University of Wyoming, Laramie's heritage as an Old West city begins in the 1860s along the overland route of the Union Pacific rail line. Like many railroad camps, Laramie quickly gained a wild reputation for lawlessness. Today's visitors can tour 15 historic sites from Laramie's early years on the Legends of Laramie Tour, sponsored by the Laramie Area Visitor Center. The tour includes the Wyoming Territorial Prison State Historic Site, Historic Iverson Mansion, the historic Laramie Union Pacific Train Station and the ghost town of Sherman at the Ames Monument.

VisitLaramie.org

READERS' CHOICE:
Dodge City, KS

HERITAGE TRAVEL

79 Crook's Black Hills Expedition

In 1876, Gen. George Crook led an army expedition into the Black Hills during the Great Sioux War. Yankton, Dakota Territory, photographer Stanley J. Morrow, who had apprenticed under Mathew Brady during the Civil War, photographed Crook's "horsemeat march," including an encampment near Deadwood.

- COURTESY LIBRARY OF CONGRESS -



80 Indian Sweat Bath

California landscape photographer Carleton E. Watkins had a studio in San Francisco, and many of his photographs reflect his career as a professional accompanying day-trippers as a hired photographer, including a group from the city visiting geysers, known as an Indian sweat bath, in Sonoma County.

- COURTESY LIBRARY OF CONGRESS -



81 Muir Glacier

Edward S. Curtis, known best for his comprehensive portrait series of North American Indians, also was an accomplished landscape photographer. On a trip to Alaska in 1899 to photograph Native tribes, he recorded the eastern section of Muir Glacier, which is now part of Glacier Bay National Park and Preserve.

— COURTESY LIBRARY OF CONGRESS —

Where the Wild West Lives

Ride into Cave Creek, a true western hideout where diverse and colorful cultures and characters converge. Take in spectacular scenery while enjoying Arizona's most popular honkytonks, superb restaurants, shopping, and cultural events—all with style and a little twist of outlaw.

CaveCreek.org • 480.488.1400
Cave Creek, Arizona

HERITAGE TRAVEL

BEST PROMOTION OF A HISTORIC PLACE

Sheridan, WY

The town of Sheridan, Wyoming, was founded in 1884 and named after General Philip Sheridan. The historic city is a gateway to the Big Horn Mountains and Little Bighorn Battlefield National Monument. When in Sheridan take a Koltiska Horse & Carriage Company tour of historic Main Street and spend a relaxing weekend in the recently restored and reopened Historic Sheridan Inn, with its superb Open Range Restaurant.

SheridanWyoming.org

READERS' CHOICE:
Dodge City, KS



82 Canyon de Chelly

Timothy H. O'Sullivan, like Dakota Territory photographer Stanley J. Morrow, apprenticed with Mathew Brady. O'Sullivan found solace in the West thousands of miles from the battlefield carnage he had photographed during the Civil War. A testament to his love of the Western lands can be seen in his images of magnificent canyonlands of the Southwest, including the towering walls of the Grand Canyon of Canyon de Chelly.

— COURTESY LIBRARY OF CONGRESS —

ALWAYS ON



NO DAILY RESORT FEE - FREE WIFI

TALKING STICK RESORT.

SCOTTSDALE | 866.877.9897 | TALKINGSTICKRESORT.COM

Locally owned and caringly operated by the Salt River Pima-Maricopa Indian Community.



- Award of Excellence (Talking Stick Resort) by Travelocity
- Best Casino (Talking Stick Resort) by Phoenix New Times
- Best Restaurant View at Dusk (Orange Sky) by AZCentral
- AAA Four Diamond Award (Talking Stick Resort) by AAA



83 Yellowstone Lake

The surveyors of the West went to great lengths to accomplish their enormous tasks, using whatever transportation was needed. In 1871, William Henry Jackson photographed members of the Hayden Survey on *Anna*, the first boat on Yellowstone Lake.

— COURTESY YELLOWSTONE NATIONAL PARK —

BEST OLD WEST TOWN TO LIVE IN

Prescott, AZ

Prescott's Courthouse Square and historic downtown welcomes visitors to enjoy the mile-high city with its heritage hotels, Whiskey Row shops and saloons, and numerous art galleries, restaurants, museums and antique shops. The city, adjacent to Prescott National Forest, is also home to Yavapai College, Embry-Riddle University and an extension of Northern Arizona University.

Visit-Prescott.com

READERS' CHOICE:
Tombstone, AZ

BEST HISTORIC CEMETERY OF THE WEST

Concordia Cemetery, TX

El Paso's historic Concordia Cemetery is home to 60,000 beloved—and not so beloved—souls, including the notorious gunslinger John Wesley Hardin. Walk the grounds and remember the heroes, heroines and common folk who rest eternally in Concordia—Buffalo Soldiers, Texas Rangers, Civil War veterans, early Mormon pioneers and numerous local legends.

ConcordiaCemetery.org

READERS' CHOICE:
Boot Hill Cemetery, Dodge City, KS

BEST PRESERVED HISTORIC FORT OF THE WEST

Fort Davis National Historic Site, TX

Deep in the heart of Trans-Pecos Texas, Fort Davis National Historic Site is one of the finest examples of Texas frontier forts built in the 1850s to protect travelers between San Antonio and El Paso. In active service to 1891, Fort Davis has been restored and is managed by the National Park Service as a frontier military living history center.

NPS.gov

READERS' CHOICE:
*Fort Laramie National Historic Site
Fort Laramie, WY*

HERITAGE TRAVEL

BEST HISTORIC RAILROAD OF THE WEST

Cumbres & Toltec Scenic Railroad
Chama, NM/Antonito, CO

Built originally as part of the San Juan Extension of the Denver & Rio Grande Western Railroad in 1880, the Cumbres & Toltec Scenic Railroad is one of the most celebrated historic rail lines in the West, and the only one between two states. The Cumbres & Toltec operates from late May to late October, and includes numerous special trains and excursions on the 64-mile line between Chama, New Mexico, and Antonito, Colorado. The National Historic Landmark steam-driven train is a thrill ride of spectacular views across the San Juan Mountains and Conejos Valley.

CumbresToltec.com

READERS' CHOICE:

Georgetown Loop Railroad
Georgetown, CO and
Durango & Silverton Narrow Gauge Railroad, Durango, CO



84 Yellowstone

William Henry Jackson courageously packed his equipment as high as his horses and mules would take him to record the geology of the region high above Yellowstone Valley for the Hayden Survey.

- COURTESY LIBRARY OF CONGRESS -

Tucson's Best* Best Kept Secret...

No worries about what to do, where to eat, or what to wear. It's all friends and family, and the attire is casual. Enjoy horseback riding, hiking and rock climbing, delicious food, and delightful camaraderie. The perfect fix for your busy lifestyle.

★ Voted #1 of 130 Hotels in Tucson on TripAdvisor for 5 Consecutive Years.

White Stallion Ranch
WhiteStallion.com
520.297.0252

Only Five Minutes from Downtown and Convention Center on Light Rail!

BUCKHORN



DENVER'S OLDEST RESTAURANT

Serving up Steaks, Buffalo, Ribs & The Old West

Lunch -- Mon-Fri from 11 am
Supper -- Daily from 5:30 p.m.

Reservations are advised

303-534-9505

www.buckhorn.com

10th Avenue & Osage, 5 blocks West of Santa Fe Dr.

FREE LIGHTED PARKING



85 Custer's Black Hills Expedition

England-born, Minnesota-raised photographer William H. Illingworth had earned a strong reputation as a photographer on army expeditions on the Northern Plains when he was hired in 1874 to accompany the famous Custer Expedition into the Black Hills.

— TRUE WEST ARCHIVES —

The Chisholm Trail was established in 1867 with the first cattle drive to Abilene, Kansas. During the next 18 years, 5 million head of cattle were driven along it from Texas to Kansas. The trail had a great economic impact on the country, and served as backdrop to many Old West legends. In 2017, communities along the route from Southern Texas to Abilene, Kansas, will celebrate the sesquicentennial of the cattle trail that changed the West. Abilene, Kansas, is planning a major event Labor Day Weekend in September 2017.

ChisholmTrail150.org

READERS' CHOICE:
Santa Fe Trail

BEST PRESERVATION OF A HISTORIC WESTERN BUILDING

Strater Hotel, Durango, CO

The Strater Hotel in the historic district of Durango, Colorado, is the perfect place to stay when vacationing in the Animas River Valley city made internationally famous by the Durango & Silverton Narrow Gauge Railroad. Opened in 1887, the Strater is a landmark hotel, luxuriously maintained and

preserved with antiques throughout the historic inn and its well-appointed rooms. Don't miss an evening in the Diamond Belle Saloon and dinner in the Mahogany Grill.

Strater.com

READERS' CHOICE:
Sheridan Inn, Sheridan, WY

BEST PRESERVED HISTORIC TRAIL

**Chisholm Trail in Texas
Oklahoma and Kansas**

Dinosaurs
to the
The Great War

PPHM
PANHANDLE-PLAINS HISTORICAL MUSEUM
2503 Fourth Avenue • Canyon, Texas 79015 panhandleplains.org

CROW CANYON
ARCHAEOLOGICAL CENTER

**The past
just got closer**

archaeology tours
and digs

for adults and teens

crowcanyon.org
800.422.8975 | Cortez, CO

86 Oreana, Nevada

Clarence King's 40th Parallel Survey team's trail across the Great Basin of Nevada included recording the communities and mining camps along their route. Photographer Timothy H. O'Sullivan's photo of Oreana, taken in 1867, captures the town's mills in action, when they were some of the busiest in the state.

— COURTESY LIBRARY OF CONGRESS —



BEST PRESERVATION EFFORT OF THE WEST

Dodge City, KS

Known as the "Queen of the Cowtowns," Dodge City is dedicated to celebrating and preserving its 19th-century history. Start at Dodge City's Visitor Center and take the historic walking tour of the city. While in Dodge City, don't miss visiting the Santa Fe Trail Rut Site National Park, the Mueller-Schmidt House and Fort Dodge (Kansas Soldiers Home).

VisitDodgeCity.org

READERS' CHOICE:

National Ranching Heritage Center, Lubbock, TX

BEST "WHO SLEPT HERE" HOTEL

Hotel Colorado, Glenwood Springs, CO

Since 1893, the luxurious Hotel Colorado, a "Grande Dame of the Rockies," has hosted presidents, celebrities and the rich and famous. Today, the Glenwood Springs landmark welcomes guests from around the world to enjoy its famous hospitality, fine dining and relaxing Rocky Mountain

atmosphere. A favorite of Presidents Theodore Roosevelt and William Howard Taft, the hotel was also frequented by numerous famous and infamous people, including "The Unsinkable" Molly Brown. Visitors wanting a special treat should request a stay in the Molly Brown Suite.

HotelColorado.com

READERS' CHOICE:

The Occidental, Buffalo, WY

Let THE Trail Take You TO THE OGALLALA, NEBRASKA



Petrified Wood & Art Gallery

Boot Hill Cowboy Cemetery
(Self-Guided Walking Tour)

Mansion on the Hill Museum
(circa 1887)

Lake McConaughy

Call 800-658-4390
for a free Visitors Packet.

OgallalaTrails.com

Sponsored by the Keith County
Visitors Committee

Concordia Cemetery

History To Die For...

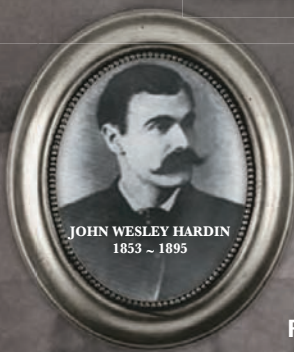

Visit one of Texas' most historic cemeteries. John Wesley Hardin, John Selman, Buffalo Soldiers, and the only dedicated Chinese Cemetery in the state.

Learn about the movers and shakers that forged the Old West.

Veterans from the War of 1812 through recent conflicts, as well as "The World's Tallest Man," reside in permanency.

Learn about former leaders of the Mexican Revolutions who were buried at Concordia.

Join the Secret Society of John Wesley Hardin - August 19, 2017 at 6 p.m., to commemorate John Wesley Hardin's demise—and on October 21, 2017, from 11:00 a.m. - 3:00 p.m., for the annual "Walk Through History."

Monthly Ghost Tours, 1st and 2nd Saturday of each month. 9 p.m. - 11 p.m.
Reservations Required: 915-274-9531.

Don't miss Dia De Los Muertos; Day of the Dead, October 28, 2017, from 2 p.m. to 8 p.m. Tours, shrines, exhibits and more.

915-842-8200 • ConcordiaCemetery.org
3700 East Yandell • El Paso, Texas



87 Zuni Pueblo

In 1873, Timothy H. O'Sullivan accompanied Lt. George H. Wheeler on his survey across the Four Corners of Arizona, Utah, Colorado and New Mexico. His talent as a photographer is equaled by his talent to recognize the significance of his subject matter, including the ancient Zuni Pueblo in New Mexico Territory.

— COURTESY LIBRARY OF CONGRESS —

BEST HERITAGE HOTEL

The Irma Hotel, WY

Built by Buffalo Bill Cody in 1902 and named after his daughter, the Irma Hotel is still “a gem” just outside the east entrance of Yellowstone National Park. Relax in modern accommodations or choose to stay in historic rooms enjoyed by Frederic Remington, Annie Oakley, Calamity Jane or Bill Cody, himself. Don't miss the restaurant and historic saloon with the cherrywood bar, a gift to Cody from Britain's Queen Victoria.

IrmaHotel.com

READERS' CHOICE:
The Strater Hotel, Durango, CO

BEST HERITAGE BED & BREAKFAST

Boot Hill Bed & Breakfast, Dodge City, KS

Built in 1927, the Boot Hill Bed & Breakfast is located in the Burr House, a Dutch Colonial Revival brick home on the National Register of Historic Buildings. Located at the top of Boot Hill, it is a wonderful and relaxing place to call home for a few days within easy walking and driving distance of Dodge City's historic sites and museums.

BootHillDodgeCity.com

READERS' CHOICE:
Gandy Dancer Inn, Chama, NM

BEST HISTORIC SALOON OF THE WEST

Big Nose Kates, Tombstone, AZ

Big Nose Kate's Saloon stands in the same location as the Grand Hotel built in 1880. The night before the “Gunfight Behind the OK Corral,” on October 26, 1881, Ike Clanton and the two McLaury brothers were guests in the Grand. While the original hotel burned in the great fire of May 25, 1882, the saloon has restored the building, moving from the basement to the main floor the only bar to survive the fire. So don't miss a chance to enjoy a cold beverage and meal on the same long bar that hosted the infamous lawmen and outlaws that made Tombstone “the town too tough to die.”

BigNoseKate.com

READERS' CHOICE:
Saloon #10, Deadwood, SD

HERITAGE
TRAVEL



Where History & Progress Meet

SCOTT CITY

EST. 1885

- El Quartejejo Museum
- Jerry Thomas Gallery & Collection
- Battle Canyon
- Lake Scott State Park
- Buffalo Ranch Tours
- Monument Rocks
- Keystone Gallery



www.scottcityks.org
620.872.5612
Scott City, KS

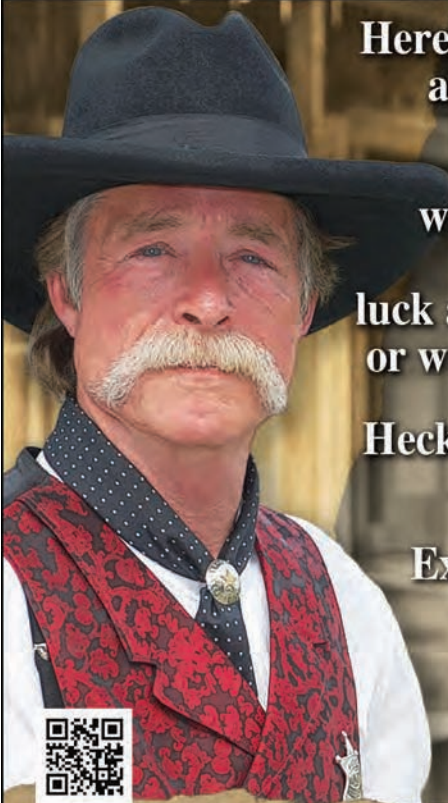

Here in Dodge City, we look at life a little differently.

Out here, you can still witness a gunfight, enjoy a great steak, try your luck at the Boot Hill Casino, or watch a beautiful sunset.

Heck, we even enjoy a great rodeo every summer.

Experience the history of Dodge City, where the Marshal still roams the streets.



800-OLD-WEST www.VisitDodgeCity.org
Dodge City Convention and Visitors Bureau

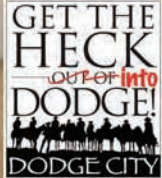

Museums, History, & Culture

Russell County Kansas

- Oil Patch Museum
- Fossil Station Museum
- Deines Cultural Center
- Garden of Eden
- History
- Wilson Lake
- Historical Water Tower

Quality Hotels & RV Parks • Unique Shopping/Eating • Epic Trails • Lake Wilson • Scenic Byway

Russell County Eco Devo & CVB
877-830-3737
www.russellcoks.org

[@RussCoKs](https://twitter.com/RussCoKs) [f Russell Kansas](https://www.facebook.com/Russell-Kansas)

KANSAS CATTLE TOWNS

Relive the days of the Drover as he celebrated the end of a long dusty cattle drive up from Texas. Visit the real cattle towns and experience the Cowboy legends of Abilene, Ellsworth, Newton, Wichita, Caldwell and Dodge City, Kansas.



For the real experience...

- Abilene - abilenekansas.org
- Ellsworth - goellsworth.com
- Caldwell - caldwellkansas.com
- Newton - thenewtonchamber.org
- Wichita - visitwichita.com
- Dodge City - boothill.org



KANSAS CATTLE TOWNS COALITION
114 1/2 N. Douglas
Ellsworth, KS 67439
KansasCattleTowns.org

COFFEYVILLE KANSAS

Come explore Dalton Raid history & re-trace the foot steps they took that fateful day in 1892!



Call for a FREE visitors guide
620.251.2550

Pendleton

OREGON



PHOTO BY TRINI HANK

*Legendary
hospitality for
generations*

501 S. Main St. • Pendleton, OR 97801
541-276-7411 • 800-547-8911

travelpendleton.com



BEST HISTORIC RESTAURANT

Buckhorn Exchange, Denver, CO

Opened in 1893, the Buckhorn Exchange holds Colorado's first liquor license. Back then, Denver railroad workers scrambled every Friday to exchange their paychecks for gold and a token for a free lunch and a beer, which filled the restaurant's register. Today, the National Historic Landmark welcomes guests to dine at lunch or dinner and enjoy the menu known for its gourmet wild game, buffalo prime rib and classic desserts.

Buckhorn.com

READERS' CHOICE:
The Palace Saloon, Prescott, AZ

BEST CHUCKWAGON COOK-OFF

Cheyenne Frontier Days, Cheyenne, WY

An annual highlight of the world-famous annual Cheyenne Frontier Days in Cheyenne, Wyoming, the Chuckwagon Cook-Off celebrates the heritage of chuckwagon cooking on the open range and cattle drives that brought cattle from Texas to Wyoming. The chuckwagon cooks

hold demonstrations and tastings for four days leading up to the championship event as part of Cheyenne Frontier Days, two weeks of events held every July.

CFRodeo.com

READERS' CHOICE:
Big Horn Heritage Days, Sheridan, WY

BEST CHUCKWAGON SHOW & SUPPER

Lincoln County Cowboy Symposium, Ruidoso, NM

Founded by legendary New Mexico cowboy singer Ray Reed in 1990, the Lincoln County Cowboy Symposium has grown from its humble roots in Glencoe, New Mexico, to one of the biggest annual festivals celebrating the cowboy way of life. Held at the Ruidoso Downs Race Track & Casino every October, the three days offer visitors world-class cowboy music, a championship chuckwagon cook-off, numerous events for the whole family and a Western Expo with over 110 vendors.

CowboySymposium.com

READERS' CHOICE:
National Cowboy Symposium & Celebration, Lubbock, TX

88 Bullion Mine

Best known as a California landscape photographer, Carleton E. Watkins made his living from selling photographs, but he was not a capable businessman, and lost it in 1875. He then ventured out in the mid-1870s to create a "New Series" of images he could sell, revisiting many of his prior subjects and locations, including mining camps such as the Bullion Mine, near Virginia City, Nevada.

- COURTESY THE J. PAUL GETTY MUSEUM AT THE GETTY CENTER -

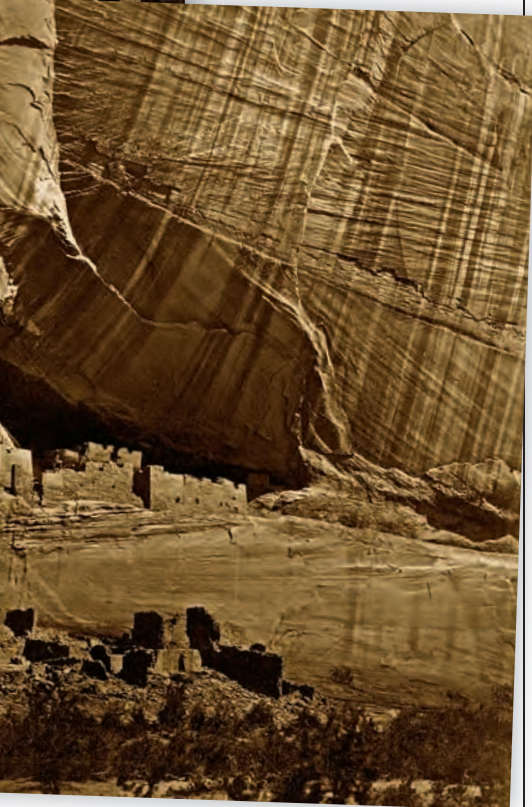

89 The White House

In 1873, Timothy H. O'Sullivan's photographic work for the Wheeler Survey brought him to the Navajo Reservation where he found inspiration in Canyon de Chelly. His image of the White House Ruin is one of the most iconic of his career.

- COURTESY LIBRARY OF CONGRESS -

BANDERA, TEXAS

Cowboy Capital of the World.®



Mark your calendars now and hit the trail for a bit of the true west in Bandera.

Western Entertainment and Nightly Music

Summer Rodeos on weekends

Cowboy Mardi Gras – February 16th - 18th

Wild Hog Explosion – March 18th

Bandera ProRodeo Association PRCA Rodeo – May 26th - 28th

RiverFest – June 24th

National Day of the American Cowboy – July 22nd

Celebrate Bandera – September 1st - 3rd

Ranch Heritage Day – October 21st



830-796-3045

BanderaCowboyCapital.com



SEE HOW AMERICA GREW

Over 50,000 historic items displayed in the order of their development in 26 buildings!

HIGHLIGHTS INCLUDE

- Buggies
- Wagons
- Harness
- Guns
- Sod House
- Indian Stockade
- Pioneer Depot
- Livery Barn
- Over 350 Autos
- 100 Tractors
- 7 Generations of Kitchens
- Buffalo Bill's Saddle
- 20 Historic Airplanes



Rated by True West 3 years running as:
Best Pioneer History Collection.

Adjoining
MOTEL & CAMPGROUND
(800) 445-4447

138 E Hwy 6, Minden NE 68959

www.pioneervillage.org



Opening May 15th, 2017

Step Back in time to the 1890's in Old Trail Town. Cody is one of Wyoming's most popular sites and is conveniently located on the road to Yellowstone National Park. This is not Hollywood, this is the real West!

307-587-5302

oldtrailtown.org

Old Trail Town • Cody, WY. 82414

90 Red Buttes

On August 24, 1870, Ferdinand V. Hayden's camp of the U.S. Geological Survey enjoyed a noon meal (note the stove, right) near Red Buttes, Wyoming Territory. Hayden, wearing a dark jacket, sits at far end of table in the William Henry Jackson photograph.

— COURTESY LIBRARY OF CONGRESS —



BEST HERITAGE GUEST RANCH

White Stallion Ranch, Tucson, AZ

Tucson's famous White Stallion Guest Ranch welcomes guests with Old West hospitality, hearty Western food, individual casitas and an old-style lodge. Western trail riding still is the best way to enjoy the saguaro-studded desert that surrounds the ranch headquarters, where several Western movies were filmed.

WhiteStallion.com

READERS' CHOICE:
Tanque Verde Ranch, Wickenburg, AZ

BEST COWBOY POETRY GATHERING

National Cowboy Symposium & Celebration, Lubbock, TX

The National Cowboy Symposium & Celebration is held every September in Lubbock, Texas, and is one of the biggest annual events in the West Texas city. The Cowboy Poetry Gathering, with dozens of performers, is one of the centerpieces of

the three-day festival, which includes a chuckwagon cook-off, numerous Western, equestrian, cowboy and Native heritage demonstrations, family events, and the ever-popular famous Parade of the Horse.

Cowboy.org

READERS' CHOICE:
National Cowboy Poetry Gathering, Elko, NV



LARAMIE

Welcomes

ROBERT FULLER

STAR OF THE WESTERN TV SHOW LARAMIE (1959-1963)



DOWNLOAD THE LARAMIE APP:

Come to the "Old West" for the 2017 Laramie Jubilee Days. Our Grand Marshall will be Mr. Robert Fuller from the western TV show *Laramie*. He will talk about his memories of the show and sign autographs at the nightly rodeo and other special events, July 14-15. Make plans to have a dinner with Robert at the Hilton Inn on the evening of July 15th.

(For dinner tickets and full schedule go to www.visitlaramie.org and click on Robert Fuller)

Robert Fuller
PLAYED JESS HARPER



LARAMIE, WYOMING - BOOK ONLINE
ALBANY • CENTENNIAL • ROCK RIVER • WOODS LANDING
WWW.VISITLARAMIE.ORG 1-800-445-5303

BEST COWBOY MUSIC GATHERING

Heber Valley Western Music & Cowboy Gathering, Heber City, UT

In 2017, the Heber Valley Western Music & Cowboy Gathering will be celebrating its 23rd year at the annual festival in Heber Valley, Utah, in late October. From regional favorite to international stars of Western music and cowboy poetry, the Heber Valley festival has entertainment for all ages, including the Mountain Man Traders Camp, Buckaroo Fair and mounted Shooters events.

HeberValleyCowboyPoetry.com

READERS' CHOICE:

Red Steagall Cowboy Gathering & Western Swing Festival Fort Worth, TX

BEST OLD WEST MOUNTED RE-ENACTMENT

Defeat of Jesse James Days Northfield, MN

Held the first weekend after Labor Day every September in Northfield, Minnesota, the Defeat of Jesse James Days offer a thrill-a-minute mounted re-enactment of the failed James-Younger Gang robbery of Northfield's First National Bank on September 7, 1876. The three-day event includes programming for all ages, but the highlight every day is the Raid Re-enactment—two on Friday, four on Saturday and two on Sunday—with enough action in every 30-minute show to ensure you leave believing you were there on that fateful day in 1876.

DJJD.org

READERS' CHOICE:

Buffalo Soldier Society of New Mexico, Albuquerque, NM

HERITAGE TRAVEL

BEST OLD WEST RE-ENACTMENT GROUP

Six Guns & Shady Ladies, El Paso, TX

The El Paso-based troupe Six Guns & Shady Ladies has entertained audiences all across the country since Bernie and Melissa Sargent founded it in 1998. With nearly 50 skits, the Wild West re-enactment group brings humor and history to every show, with thrilling gunfights, including the famous "Four Dead in Five Seconds."

SixGunsAndShadyLadies.Homestead.com

READERS' CHOICE:

Prescott Regulators & Their Shady Ladies, Prescott, AZ

RESTAURANT & SALOON
BUFFALO BILL'S
IRMA HOTEL
EST. 1902

STEP BACK IN TIME...into the old west of today, at the Irma Hotel – the heart and spirit of Cody, Wyoming! Enjoy cozy accommodations, fine dining (and the best prime rib in town), entertainment, the Silver Saddle Saloon, our Western Gift Shop and more.

THE INFAMOUS CODY GUNFIGHTERS perform for FREE nightly in front of the Irma Hotel. Join in the fun on the Irma porch at 6 p.m. Monday through Saturday from June through September!

1192 Sheridan Avenue
 Cody, WY 82414

Phone: 307.587.4221
 1.800.745.4762

www.irmahotel.com

Buffalo Bill's ANTLERS INN
www.codymotorlodge.net

Buffalo Bill's Cody Motor Lodge
 AAA Approved
www.antlersinn Cody.com

Cody Gunfighters
www.codygunfighters.com



HERITAGE TRAVEL

91 John K. Hillers

John K. Hillers quickly learned photography on the 1872 Powell Expedition, working his way up from oarsman to primary cameraman for Powell's Geological Survey. He was photographed working with negatives in the Survey's camp on the Aquarius Plateau of the Utah Territory.

- COURTESY LIBRARY OF CONGRESS -

92 William Henry Jackson

In 1871, William Henry Jackson (right, with pipe) was the official photographer on the Hayden Survey of Yellowstone. He used a large format camera and made photographs using the "wet plate process." Jackson had five to seven men with mules to carry his 300 pounds of gear.

- COURTESY YELLOWSTONE NATIONAL PARK -



WANTED

THOSE BRAVE ENOUGH TO EXPLORE
THE BEST OF THE WEST

IN BUFFALO
& KAYCEE,
WYOMING



EXPERIENCE
THE OLD WEST...



BUFFALOWYO.COM
KAYCEEWYOMING.ORG
800-227-5122

EXPLORE
THE NEW WEST



93 Shoshone Cañon and Falls

In 1868, Timothy H. O'Sullivan accompanied the Clarence King Survey of the 40th Parallel across the Great Basin. O'Sullivan's images of the Snake River, Shoshone Canyon and Falls remain some of his finest images, many of which captured the geology and fellow members of the survey party, providing scale to the immensity of the scene.

— COURTESY LIBRARY OF CONGRESS —

■ BEST WILD WEST SHOW

Buffalo Bill Wild West Show, Cody, WY

The Rocky Mountain Dance Theatre's Buffalo Bill Wild West Show premiered in 2016 in the theatre and has already scheduled its second exciting year for June 21-July 29, 2017, Wednesday to Saturday evenings with a matinee every Saturday. Held in the Historic Cody Theatre in downtown Cody, the musical celebrates Buffalo Bill Cody's dream of becoming the

world's most famous entertainer, and includes cast members portraying many of the showman's famous friends, including Annie Oakley, Sitting Bull and Wild Bill Hickok.

CodyWildWestShow.com

READERS' CHOICE:
Whiskey Row Shootout, Prescott, AZ

■ BEST HISTORIC WESTERN RODEO

Pendleton Round-Up, Pendleton, OR

Since 1910, the Pendleton Round-Up has been held in the same location with no in-arena advertising. The Oregon Heritage Culture Event continues as the "epic drama of the West" with its wooden chutes and unique, timed run-down alley.

PendletonRoundUp.com

READERS' CHOICE:
The World's Oldest Rodeo, Prescott, AZ

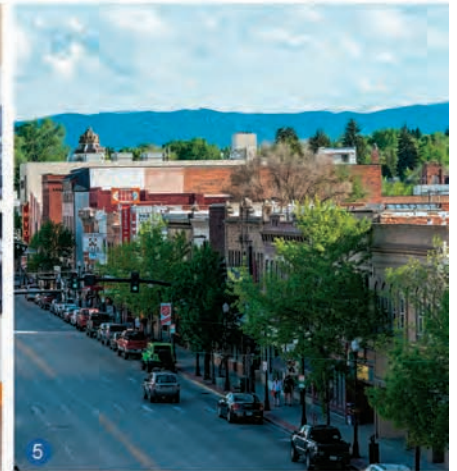

A WEEKEND AWAY IN SHERIDAN, WYOMING

EXPERIENCE SHERIDAN'S HISTORIC ATTRACTIONS IN 48 WHIRLWIND HOURS

Day 1. Rise and shine in either the “Sitting Bull Room” or “Wild Bill Hickok” suite at the **Sheridan Inn (1)** (sheridaninn.com), Buffalo Bill Cody’s former stomping grounds. Each room at the Inn is unique and named for important figures in Buffalo Bill’s life. After breakfast, take a drive to the **Little Bighorn National Monument**, the site of the crucial 1876 battle between George Armstrong Custer and the Sioux. After, return to town and enjoy the old west marvels at the **Don King Museum (2)** (kingssaddlery.com). Housing everything from horse-drawn hearses, an incredible

old west photo archive, a remarkable collection of saddles, and Indian artifacts, the Don King Museum offers a glimpse at life in the West through the years. Before dinner, take a tour of the **Trail End State Historic Site (3)** (trailend.co). Built in Flemish Revival style, the Trail End mansion examines an elegantly different aspect of Wyoming’s rich and colorful history, and shouldn’t be missed.

Day 2. Rise to beat the crowds of history buffs and tour Indian battle sites and former military posts, including the **Rosebud and Connor Battlefields**, the site of the **Wagon Box Fight**, and finally picturesque

Ft Phil Kearny (fortphilkearny.com), located on the historic **Bozeman Trail**. After lunch, plan to spend a few hours exploring **The Brinton Museum (4)** (brintonmuseum.org) in Big Horn for a look at one of the most robust collections of Indian and western artifacts in the West, then shop for a new pair of cowboy boots in **Historic Downtown Sheridan (5)**. **The Sheridan County Museum** boasts a robust archive of historical images, artifacts and letters, and serves as an excellent exclamation point on your tour. After dinner, kick up your boots on the porch of the Historic Sheridan Inn the way Buffalo Bill once did, and watch the sun set on your time in Sheridan.

For more on these, and other adventures in Sheridan, please find us on Facebook, Twitter and Instagram, and visit us online at www.sheridanwyoming.org.

WYOMING’S EMERALD GEM, SHERIDAN BLENDS QUINTESSENTIAL COWBOY CULTURE, MODERN WEST ALLURE, AND COUNTRY CHARM.

BUFFALO BILL CODY IN SHERIDAN – 122 YEARS AGO

Constructed in 1892 as part of a railway extension program, the Sheridan Inn was the first building in the area furnished with electrical power and bathtubs, giving adventurous travelers a taste of Eastern luxury in the West and was considered the finest hotel between Chicago and San Francisco. Buffalo Bill Cody frequented the Sheridan Inn as part owner and held auditions for his Wild West Show from the iconic front porch of the Inn.





PLAN TO ATTEND
37th ANNUAL
**HELLS
CANYON
MULE
DAYS**

ENTERPRISE, OREGON **Rated "E" for Everyone!**

The Weekend After Labor Day
SEPTEMBER 8-9-10, 2017
Enterprise, Oregon

MULE SHOW & P. T. SALE
COWBOY POETRY GATHERING
MULE CLINICS
NON-MOTORIZED PARADE
PIT B-B-Q DINNER
COWBOY CHURCH – D.O. COOK-OFF
VENDORS/EXHIBITS & WESTERN GEAR
MULE ARTIST – BONNIE SHIELDS
SAT. NIGHT CONCERT



SHOW INFO: SONDRA LOZIER
541-426-3271 or 541-263-0104
visit: www.hellscanyonmuledays.com

EXPERIENCE A GREAT TIME IN N.E. OREGON

Western History
For All Generations



**Stuhr
Museum**

Grand Island, NE (308 385-5316)
www.stuhrmuseum.org
[Facebook.com/StuhrMuseum](https://www.facebook.com/StuhrMuseum)



94 First Photo of Yosemite

Charles Leander Weed was an early Sacramento, California, photographer. Entrepreneur James Hutching brought Weed to Yosemite to be the first photographer to take images of the spectacular valley in June 1859, including Yosemite Falls from the south bank of the Merced River.

– COURTESY UC BERKELEY, BANCROFT LIBRARY –

95 Mariposa Trail

In 1864, Charles Leander Weed returned to photograph Yosemite Valley with his large-format camera that used 22 x 28-inch glass plates. His 30 albumen prints, published by Lawrence & Houseworth, earned him the 1867 Paris International Exhibition's first-place bronze medal.

– TRUE WEST ARCHIVES –



HERITAGE TRAVEL



96 Two Whistles

For his survey of North American Indians in 1908, ethnologist and photographer Edward Curtis photographed an Absaroke (Crow) man wearing traditional face paint, medicine hawk headdress, buckskin shirt and shell necklaces.

- COURTESY LIBRARY OF CONGRESS -



CHEYENNE

W Y O M I N G

Live the Legend™

CHEYENNE FRONTIER DAYS™

OLD WEST MUSEUM AND STORE

HISTORIC CHEYENNE DEPOT

WYOMING STATE CAPITOL AND STATE MUSEUM

NELSON MUSEUM OF THE WEST

TERRY BISON RANCH

CHEYENNE STREET RAILWAY TROLLEY

BIT-O-WYO HORSE BARN DINNER SHOW

Plus There's So Much More!

CHEYENNE, WYOMING!

AT THE CROSSROADS OF I-80 & I-25

WWW.CHEYENNE.ORG ~ 800-426-5009

Knights Museum and Sandhills Center

On the edge of the Nebraska Sandhills.

A Railroad town.

A Cow-town.

An Ag town.

Where history runs deep.

Largest Genealogy Center in Western Nebraska

Building the Best Hometown in America

KnightsMuseum.com

SPUR YOUR SOUL

IN SCOTTS BLUFF COUNTY

VisitScottsBluff.com 800-788-9475

NEBRASKA'S LANDMARK COUNTRY
Scottsbluff - Gering

HERITAGE TRAVEL



97 Powell's Boat

Oarsman-turned-Second Powell Expedition photographer John K. Hillers took this photo of John Wesley Powell's famous boat with its mounted chair on the banks of the Colorado River in the Grand Canyon. The image perfectly reflects the simplicity and the immensity of the journey.

- COURTESY LIBRARY OF CONGRESS -

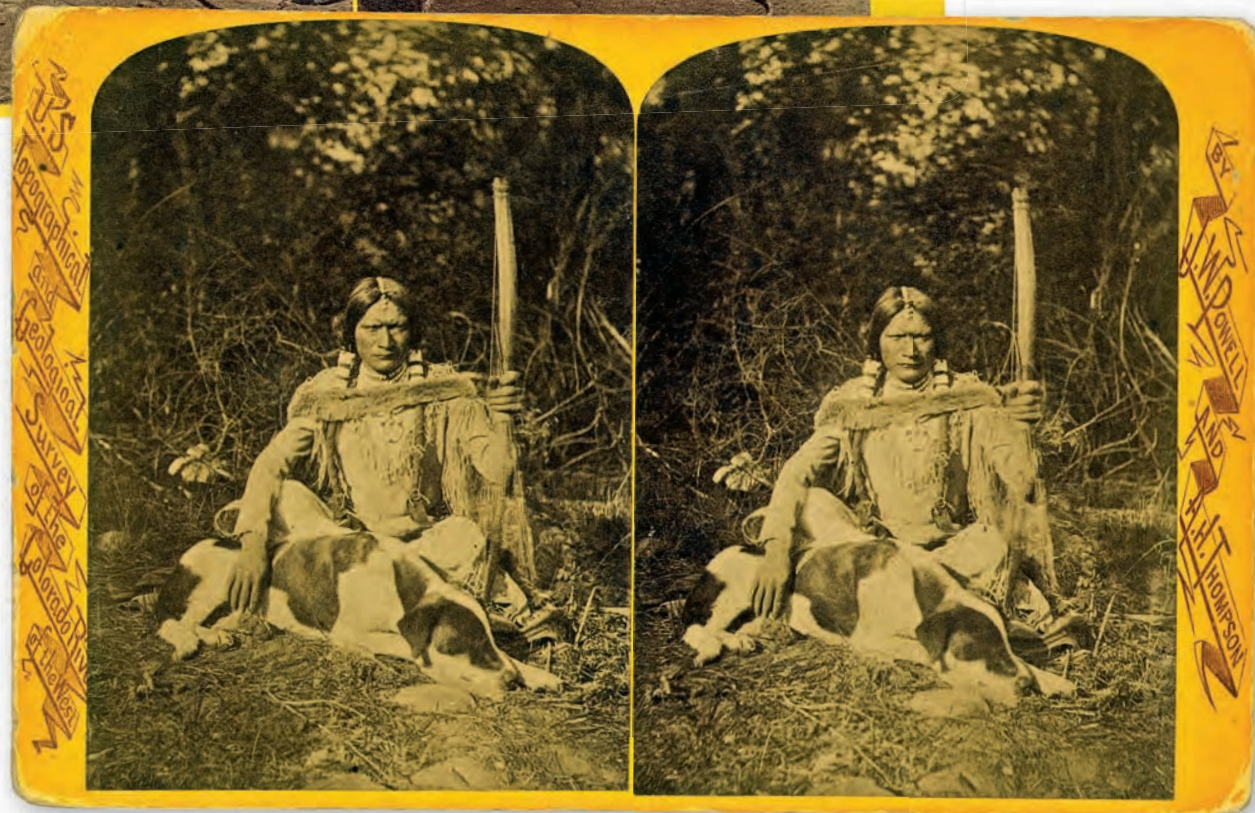

98 The Messenger

As John Wesley Powell's photographer on the Powell Survey in 1874, John K. Hillers photographed many of the American Indians they met during the survey's geologic work, including "The Messenger" in full dress.

- COURTESY LIBRARY OF CONGRESS -

99 Malakoff Diggins

In 1871, Carleton E. Watkins photographed the expansive environmental affects of hydraulic mining at the Malakoff Diggins in North Bloomfield, California. The San Francisco photographer's images of mining provide an insightful view of the industrialization of the West—and the largest hydraulic operation in California history. Today, Malakoff Diggins State Park provides visitors an insightful view on mining history in the West.

— COURTESY THE J. PAUL GETTY MUSEUM AT THE GETTY CENTER —



Get Your West on

facebook.com/carboncountyyw

CARBON COUNTY WYOMING

GET YOUR WEST ON

Visit our web site for museum information & a free visitors guide.

www.wyomingcarboncounty.com

Sponsored by the Carbon County Visitors' Council



MY GREAT PLACE IS DEADWOOD, SD



See the graves of western legends Wild Bill Hickok, Calamity Jane and Seth Bullock, visit world-class museums, take a historic walking tour and see how the West was really won in our gaming halls and casinos. Located in the Black Hills, Historic Deadwood has been entertaining guests since 1876. Make it your Great Place in South Dakota.



WESTERN ROUNDUP

FOR JANUARY 2017



THE ARTISTS OF TAOS

Scottsdale, AZ, January 10- April 20: This exhibition features many of the finest artworks by members of the Taos Society of Artists—one of the most influential and highly acclaimed artist groups in the nation's history.
480-686-9539 • ScottsdaleMuseumWest.org

ART SHOW

CAREFREE FINE ART & WINE FESTIVAL

Carefree, AZ, January 20-22: High Sonoran Desert town closes its streets for Southwestern and American Indian art show and wine tastings.
480-837-5637 • ThunderbirdArtists.com

HERITAGE FESTIVALS

POLAR BEAR STOMP

Eagle Nest, NM, January 1: Kick off the new year with an hour-long snow hike around Eagle Nest Lake State Park; end with a cup of hot chocolate.
575-377-3010 • AngelFireChamber.org

LITCHFIELD PARK NATIVE AMERICAN ARTS FESTIVAL

Litchfield Park, AZ, January 13-15: The 25th annual gathering of American Indian artists who display jewelry, pottery, katsinas and beadwork.
623-935-9040 • Litchfield-Park.org

RODEO

COWBOYS OF COLOR RODEO

Fort Worth, TX, January 13: Held since 1995, this rodeo brings together cowboys from diverse cultures to celebrate their Western heritage.
817-922-9999 • CowboysOfColor.org

FORT WORTH STOCK SHOW & RODEO

Fort Worth, TX, Opens January 13-February 4: Held since 1896, Fort Worth's exposition livestock show and rodeo attract cowboys to its auctions, livestock and horse shows, rodeos and concerts.
817-877-2400 • FWSSR.com

PBR BUILT TOUGH

Oklahoma City, OK, January 21-22: Witness the "toughest sport on dirt" in this family-friendly experience of top professional bull riding.
800-745-3000 • VisitOKC.com

BY JOHN LANGELLIER

JIM YOUNG: FORGOTTEN ARIZONA PIONEER FINALLY GETS HIS DUE



This snapshot taken of Jim Young (left) in Tombstone, Arizona, in July 1927, reveals how, even in old age, he remained an imposing figure. In his younger days, Young acted as a bodyguard for John Slaughter (below) during his weekly poker games in Bisbee. With a shotgun-wielding Young stationed outside, no one ever attempted to hijack the pot.

— YOUNG PHOTO COURTESY ARIZONA STATE ARCHIVES / YOUNG ILLUSTRATION BY BOB BOZE BELL —

McLeod, who had considerably more experience in the ring, and bested his opponent, despite a weight disadvantage of 10 pounds. Tradition has it that, the next year, Young faced the formidable John L. Sullivan, who was making a swing through the West to take on local champions.

Young remained in southern Arizona past the age of 90. The 1930 U.S. census carried him on the rolls at age 86 and listed his religion as “Hindu!”

Regrettably, unlike Tombstone’s famous and sometimes

infamous denizens, such as the Earps and Clantons, little of Young’s final days are known, although he did work as a caretaker at Holy Hope Cemetery, which is where, after his death on January 19, 1935, this destitute, weary player in the drama of Arizona’s halcyon days was laid to rest.

For all these years, Young’s grave has had no headstone. When I was researching the Apache Kid, the unsung Arizona pioneer’s name surfaced. I unearthed tantalizing glimpses into Young’s life, including an obituary that led me to his unmarked grave.

If you would like to join *True West’s* ceremony, find out more details by visiting *TWMag.com* and searching for “Cemetery Marker Ceremony for Tombstone’s Unsung Hero.”



On January 16, Martin Luther King Day, Bob Boze Bell and John Langellier will recognize a long overlooked character linked to the “Town Too Tough to Die” by placing a marker on Jim Young’s grave in Tucson, Arizona.

Standing more than six feet tall, Young, like many other antebellum blacks, did not know the date of his birth nor even the names of his parents.

After the Civil War, the slave-turned-freedman headed west, where he eventually hooked up with “Texas” John Slaughter, in the Lone Star State, who was on the move to New Mexico and Arizona Territories.

When Young reached Arizona in the 1870s, he worked for Slaughter as a bodyguard and cowhand. Young also worked in the mines and staked a claim for himself. While defending his claim, he backed down “Buckskin Frank” Leslie not once, but twice!

He even turned to boxing. In 1883, he went four rounds with pugilist Neil



NEW YEAR'S DAY BRUNCH TRAIN

Durango, CO, January 1: Start the New Year aboard the Durango & Silverton Narrow Gauge Railroad's steam-powered train on this trip reminiscent of 19th-century travel. 888-827-4607 • DurangoTrain.com



COLORADO INDIAN MARKET AND SOUTHWEST SHOWCASE

Denver, CO, January 20-22: Held since 1981, this Southwest market showcases American Indian art and tribal performances for a full experience. 972-398-0052 • IndianMarket.net



NATIONAL WESTERN STOCK SHOW

Denver, CO, January 7-22: Since 1906, this show hosts livestock and horse sales and seminars, plus rodeo events, at National Western Complex. 303-296-6977 • NationalWestern.com

GET 'EM

Order yours before they are gone!

True West is one of the most collectible history magazines in the world. (Back issues have sold for as high as \$300!) Collect your favorites now, as the love for history will never go out of date!

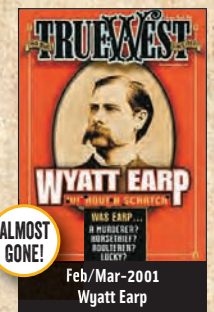

WHILE THEY LAST!

Complete Your Collection

2000

- Jan: Buffalo Bill
- Mar: Richard Farnsworth
- May: Samuel Walker
- Jun: Frontier Half-Bloods
- Jul: Billy & the Kids
- Aug: John Wayne
- Sep: Border Breed
- Oct: Halloween Issue
- Nov: Apache Scout
- Dec: Mountain Men

2001

- Jan: Topless Gunfighter
- May/Jun: Custer
- Jul: Cowboys & Cowtowns

2002

- Aug/Sep: Jesse James
- Oct: Billy On The Brain
- Nov/Dec: Butch & Sundance

2003

- Jan: 50 Historical Photos
- Feb/Mar: 50 Guns
- Apr: John Wayne
- Spring: Jackalope Creator Dies
- May/Jun: Custer Killer
- Jul: Doc & Wyatt
- Aug/Sep: A General Named Dorothy
- Oct: Vera McGinnis
- Nov/Dec: Worst Westerns Ever

2004

- Jan/Feb: Six Guns
- Mar: Fakes/Fake Doc
- April/Travel: Visit the Old West
- May: Iron Horse/Sacred Dogs
- Jun: HBO's Deadwood
- Jul: 17 Legends
- Aug: JW Hardin
- Sep: Wild Bunch
- Oct: Bill Pickett
- Nov/Dec: Dale Evans

2005

- Jan/Feb: Rare Photos
- Mar: Deadwood/McShane
- Apr: 77 Sunset Trips
- May: Trains/Collector's Edition
- Jun: Jesus Out West
- Jul: All Things Cowboy
- Aug: History of Western Wear
- Sep: Gambling
- Oct: Blaze Away/Wyatt
- Nov/Dec: Gay Western? Killer DVDs

2006

- Jan/Feb: Mexican Insurgents
- Mar: Kit Carson
- Apr: I've Been Everywhere, Man
- May: The Racial Frontier
- Jun: Playing Sports in the OW
- Jul/Aug: Dude! Where's My Ranch?
- Sep: Indian Yell
- Oct: Tombstone/125th Ok Corral
- Nov: Gambling
- Dec: Buffalo Gals & Guys

2007

- Jan/Feb: Cowboys Are Indians
- Mar: Trains/Jim Clark
- Apr: Western Travel
- May: Dreamscape Desperado/Billy
- Jun: Collecting the West/Photos
- Jul: Man Who Saved The West
- Aug: Western Media/Best Reads
- Sep: Endurance Of The Horse
- Oct: 3:10 To Yuma
- Nov/Dec: Brad Pitt & Jesse James

2008

- Jan/Feb: Pat Garrett/No Country
- Mar: Who Killed the Train?
- Apr: Travel/Geronimo
- May: Who Stole Buffalo Bill's Home?
- Jun: The Last Cowboy President?
- Jul: Secrets of Our Nat'l Parks/Teddy
- Aug: Kendricks Northern CBS/Photos
- Sep: Saloons & Stagecoaches

- Oct: Charlie Russell
- Nov/Dec: Mickey Free

2009

- Jan/Feb: Border Riders
- Mar: Poncho Villa
- Apr: Stagecoach
- May: Battle For The Alamo
- Jun: Custer's Ride To Glory
- Jul: Am West, Then & Now
- Aug: Wild West Shows
- Sep: Vaquero/500 Yrs Before CBS
- Oct: Capturing Billy
- Nov/Dec: Chaco Canyon

2010

- Jan/Feb: Top 10 Western Towns
- Mar: Trains/Pony Express
- Apr: OW Destinations/Clint Eastwood
- May: Legendary Sonny Jim
- Jun: Extreme Western Adventures
- Jul: Starvation Trail/AZ Rough Riders
- Aug: Digging Up Billy the Kid
- Sep: Classic Rodeo!
- Oct: Extraordinary Western Art
- Nov/Dec: Black Warriors of the West

2011

- Jan/Feb: Sweethearts of the Rodeo
- Mar: 175th Anniv Battle of the Alamo
- Apr: Three True Grits
- May: Historic Ranches
- Jun: Tin Type Billy
- Jul: Viva, Outlaw Women!
- Aug: Was Geronimo A Terrorist?
- Sep: Western Museums/CBS & Aliens
- Oct: Hard Targets
- Nov/Dec: Butch Cassidy is Back

2012

- Feb: Az Crazy Road to Statehood
- Mar: Special Entertainment Issue
- Apr: Riding Shotgun with History
- May: The Outlaw Cowboys of NM
- Jun: Wyatt On The Set!
- July: Deadly Trackers
- Aug: How Did Butch & Sundance Die?

- Sep: The Heros of Northfield
- Oct: Bravest Lawman You Never
- Nov: Armed & Courageous
- Dec: Legend of Climax Jim

2013

- Jan: Best of the West/John Wayne
- Feb: Rocky Mountain Rangers
- Apr: US Marshals
- May: Texas Rangers
- Jun: Doc's Last Gunfight
- Jul: Comanche Killers!
- Aug: Tombstone 20th Annv
- Sep: Ambushed on the Pecos
- Oct: Outlaws, Lawmen & Gunfighters
- Nov: Soiled Doves
- Dec: Cowboy Ground Zero

2014

- Jan: Best 100 Historical Photos
- Feb: Assn. of Pat Garrett
- Mar: Stand-up Gunfights
- Apr: Wyatt Earp Alaska
- May: Tom Horn
- Jun: Custer Captured
- Jul: 50 Historical Gunfighter Photos
- Aug: Bigfoot Wallace/Train Robberies
- Sep: New Billy Photo/Top Museums
- Oct: Charlie Russell/Movie Hats
- Nov: Wild Bills's Last Gunfight
- Dec: Olive Oatman-Branded

2015

- Jan: 100 Historical Am. Indian Photos
- Feb: Mountain Man-First Survivalists
- Mar: Mickey Free/Severed Heads
- Apr: Jack Stilwell-Forgotten Scout
- May: Armed to Survive
- Jun: Billy the Kid-Special Report
- Jul: 50 Historical Photos-Pancho Villa
- Aug: Luke Short-Dodge City War
- Sep: Crossing America-Lewis & Clark
- Oct: Wyatt Earp in Hollywood
- Nov: 22 Guns that Won the West
- Dec: The First Mountain Man

See the complete collection of available back issues
online at the True West Store!

Store.TrueWestMagazine.com

1-888-687-1881



Indian Captives Freed

When were the last captives of the Indian freed?

Robert Matters
Hilliard, Ohio

That's hard to say as so many different tribes took captives, but the last captives were probably freed in the 1890s.

Adult men were rarely, if ever, taken alive, but boys often grew up in the tribe and chose to remain. Same with girls and young women. While history offers dozens of accounts of rape, beatings, abuse, enslavement and brutality, we also see instances of captive women marrying Indian men—Cynthia Ann Parker being a well-known example.

Books sharing accounts written by captives include Gregory and Susan Michno's *A Fate Worse than Death* and L.R. Bailey's *Indian Slave Trade in the Southwest*. Wild West History Association First Vice President Roy Young recommends Clinton L. Smith's *The Boy Captives* and Scott Zesch's *The Captured: A True Story of Abduction by Indians on the Texas Frontier*.

Where was Frank Patterson's ranch in Cochise County?

Randi O'Neal
Whetstone, Arizona

Paul Lee Johnson's 2012 book, *The McLaurys in Tombstone, Arizona*, notes that the McLaury family's first ranch was near the Babocomari River in Arizona Territory, just north of the 1866 military post Camp Wallen. Frank Patterson's nearby ranch was reportedly

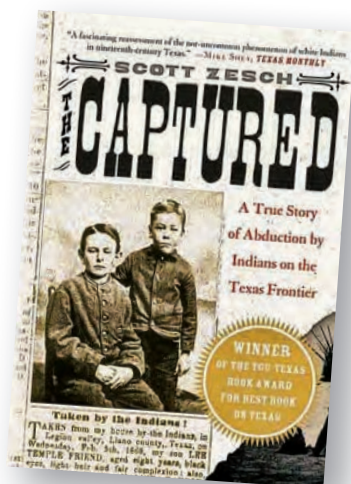

Scott Zesch's tale of Indian abductions on the Texas frontier was named the "Best Book on Texas" by the TCU Library in Fort Worth.

— COURTESY ST. MARTIN'S PRESS —

where "Curly Bill" Brocius was buried after lawman Wyatt Earp killed him at Iron Springs (now Mescal Springs) in 1882.

What happened in the feud between John Slaughter and Barney Gallagher?

Edward Dingle
Mesa, Arizona

Trouble between the two started sometime in 1876, when John Slaughter caught Barney Gallagher cheating during a poker game at a Commerce Street establishment in San Antonio, Texas.

Gallagher and a cowboy named Boyd followed Slaughter to John Chisum's ranch near Roswell, New Mexico, where Slaughter's herd was grazing. Gallagher had either pilfered some of Slaughter's cows or planned to do so.

Gallagher had been drinking, and, in several accounts, had threatened to kill Slaughter. It's unclear who fired first, but Slaughter didn't miss.

Was Clay Allison convicted of spying for the Confederacy and sentenced to be shot around May 1865, only to escape after killing his guard?

Jonathan Smith
Rodenberg, Lower Saxony, Germany

"To tell you the truth, this seems to be a 1950s myth, created during a time when hacks were 'punching up' Old West stories to meet the movie demand," outlaw-lawman researcher Dennis McCown says. "So much in the 1950s is colored by a hope



Ask The Marshall

BY MARSHALL TRIMBLE

Marshall Trimble is Arizona's official historian and vice president of the Wild West History Association. His latest book is *Arizona's Outlaws and Lawmen*; History Press, 2015.

If you have a question, write: Ask the Marshall, P.O. Box 8008, Cave Creek, AZ 85327 or e-mail him at marshall.trimble@scottsdalecc.edu

to sell screen rights. It was the 'Golden Age' of TV shows and Western-themed movies. There was money to be made—and history be damned. I've never found a historical reference to support this claim."

Al Sieber was famous as a scout and Indian fighter, but why didn't he get the Medal of Honor?

Allen Fossenkemper
Fountain Hills, Arizona

As chief of scouts for the U.S. Army, Sieber was a civilian. Only six civilians (including William F. "Buffalo Bill" Cody) were awarded the Medal of Honor. All of those were retracted in 1917, when the medal became exclusively a military



Chief of Scouts Al Sieber

— TRUE WEST ARCHIVES —



100 Apache Scouts

Apache scouts worked for the U.S. Army during the Apache Wars up to 1886, although the last scout retired in the 1940s. Timothy H. O'Sullivan took this photo of the scouts at Apache Lake in Sierra Blanca Range in Arizona Territory in 1873.

— COURTESY LIBRARY OF CONGRESS —

honor, although the Army reinstated them in 1977 and 1989. Personally, I think Sieber deserved one.

How important were the U.S. Army's Apache scouts?

*Duff Hale
Midlothian, Texas*

One of the smartest strategic moves by the frontier army during the Indian Wars was to enlist American Indians as scouts.

Apaches were formidable foes in New Mexico, Arizona and in the Mexican cities of Chihuahua and Sonora. The wild, untamed land worked to their advantage, making them almost impossible to find. The U.S. Army successfully enlisted Apache scouts to locate and hunt down other Apaches who refused to live on the reservations.

Officers from Gen. George Crook to Capt. John Bourke to Lt. Britton Davis all wrote glowing accounts of the bravery and persistence of these Apache scouts,

saying they were invaluable on the campaign trail.

Bourke wrote, "The longer we knew the Apache scouts, the better we liked them." Apache Wars historian Dan Thrapp added: "It grew increasingly apparent that the success of the troops depended on the scouts. Without scouts, the troops couldn't find the enemy; with scouts they rarely missed. It was as simple as that."

Unfortunately, the country didn't appreciate their service. After the Apache Wars finished, the federal government exiled the scouts to Florida with all the other Chiricahua Apaches.

Just how prevalent was profanity in the Old West?

*Mary Lynn Wirick
Irving, Texas*

Profanity has been around for thousands of years and just about every culture uses it.

Until around the 1870s, profanity was considered much more offensive than it is today. Especially bad: terms with a religious bent (like "Jesus," "God damn" and even "Hell"). And saying such things in front of ladies was considered uncouth.

During the Mexican-American War in the Southwest, settlers along New Mexico's Rio Grande Valley referred to the rough and tumble Missouri volunteers as the "los goddammys" because of their frequent use of the word.

Did frontier trappers work in the Southwest region?

*Hub Whitt
Thermopolis, Wyoming*

Absolutely. Trappers found plenty of pelts in modern-day Arizona, New Mexico and Colorado—areas that were part of Mexico during the first half of the 19th century.

Such fluid country borders presented a major problem when trapping in the Southwest. A party could lose an entire season's trapping if some unscrupulous government official decided to confiscate their furs.

Beavers were plentiful in the Gila River and its tributaries, especially in the 1820s. Ewing Young, Joe Walker, Kit Carson, George Yount, Ceran St. Vrain and Antoine Robidoux all trapped in the Gila country. They also used Bent's Fort, on the American side of the Arkansas River, to launch expeditions into the Southwest.

For more, I recommend you read Robert Glass Cleland's excellent book on the Southwest fur trade, *This Reckless Breed of Men*. 

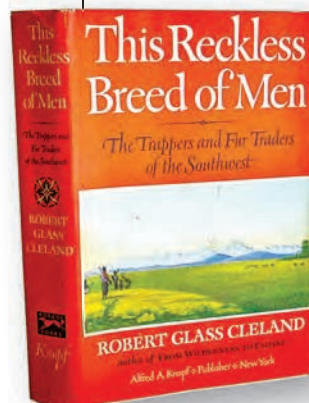

Princeton graduate Robert Glass Cleland, born in 1885, saw his superb general history of the Southwest fur trade published just seven years before the historian died at the age of 72.

— COURTESY ALFRED A. KNOPF —

What HISTORY HAS TAUGHT ME

I got interested in the Old West when, as a six year old, I was watching *The Life and Legend of Wyatt Earp*, starring Hugh O'Brian. My Dad walked through the room and asked, "You know he was a real guy, right?" I was dumbfounded.

The problem with so many Billy the Kid buffs is that they all want to be the most knowledgeable person in the room.

The crisis in Lincoln in 1878 could have been solved with a partnership.

A tourist once asked me, "Where was Billy the Kid hanged?" Heavy sigh. People on my tours always ask me, "Were Pat Garrett and Billy the Kid really best friends?"

If I could recommend just one book on Billy the Kid, it would be Frederick Nolan's *The West of Billy the Kid*.

The problem with Westerns today is most of them are made cheaply and use 1950s B-Westerns as their model. When *Tombstone* came out, we all thought the 1993 film would herald a change to more historically accurate productions. But they couldn't go back to the old formats quickly enough—*way* too many Australian dusters! The best Western, for my money, is Clint Eastwood's *Unforgiven*.

My Daddy always told me: "Don't mix alcohol and gunpowder—it tastes *awful*."

The biggest risk I have ever taken was joining the military in 1968. Enough said.

A history novice should read everything you can get your hands on. You will find that, despite all of the differences in all of the books, a common thread of information runs through all of them, and *that* is what happened. Usually.

One Old West character I never tire of is Cole Younger. He was a loyal friend, which counts for a lot in my book. I also love how, in his "autobiography" (actually a series of lectures he did), he points out how he has found the Lord. Almost immediately thereafter, he claims the Younger brothers and James brothers had nothing to do with the Northfield raid.

My favorite place in the entire West is Lincoln, New Mexico—despite what the state of New Mexico is currently trying to do to it.



For a decade of his life, Drew Gomber once had an unusual roommate—a 160-pound gray wolf, Lazarus (shown with Drew here), that stood 33 inches tall at the shoulder.

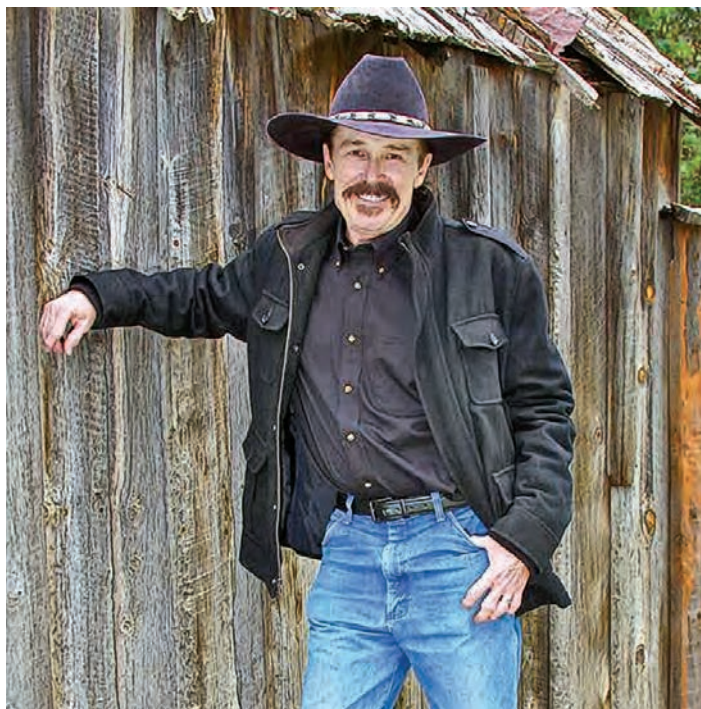

DREW GOMBER, HISTORY BUFF

For 15 years, Drew Gomber led tourists on tours of historic Lincoln and Lincoln County in New Mexico, helping them walk in the footsteps of Billy the Kid, follow the paths of people who fought in the Lincoln County War and explore the sites of legendary gunfights. He retired from tours last year to focus on his writing career. He is a frequent contributor to the *Ruidoso News* and *The Tombstone Epitaph* and has discussed Old West history on shows for the History Channel, Biography and Discovery.

On a road trip, I am the one who always seems to get the wrong seat in the vehicle. Some years back, a bunch of historian friends and I were in northern New Mexico, searching for a particular gunfight site. We traversed roads that would barely pass as trails, and were snow covered to boot. At one point, the driver, a boy scout, lost control of our vehicle, which careened to a stop on a small berm, looking down at about a 500-foot drop. The driver turned to me, as I was seated in shotgun (or, in this case, the "death seat") and asked, "Sir, are you a religious man?" And at that moment, I was.

To be a perfect guest at my house, you will be nice to my wife and dogs. Even if they are biting you.

Humor is something that makes us laugh, no matter how dumb, but does not hurt anyone, either. The problem with most humor writers today is only they think they are funny.

History has taught me that we need to learn from our mistakes. But who does that?



ANDY THOMAS



Wild Bill vs Dave Tutt



Wild Bill's Last Deal

Order your paper or canvas reproductions at: www.andythomas.com

studio: 417.359.8787

email: studio@andythomas.com



Men's Vest \$36⁹⁸_{&UP}



4X Felts \$119⁹⁸_{&UP}

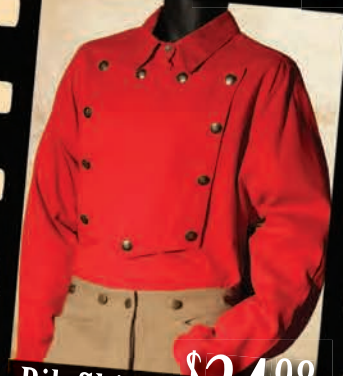

Bib Shirts \$34⁹⁸_{&UP}



Ladies Apparel Sale



Cowboy
Turtlenecks
\$16⁹⁸_{&UP}

Over 60 Styles!



WWW.FORTBRANDS.COM