

DODGE CITY'S BOOT HILL MUSEUM #1 IN THE WEST!

OUR 63RD YEAR

SEPTEMBER 2016

TRUE WEST

HISTORY OF THE AMERICAN FRONTIER

THE WALK DOWN



HISTORIANS WEIGH IN ON THE MOST FAMOUS STROLL IN FRONTIER HISTORY

Plus!

**A SMOKING GUN:
NEW EVIDENCE OF
WYATT EARP FIXING A FIGHT**

**HOW JOHNNY BEHAN
CHANGED HISTORY**

**PAGE 34: ANOTHER PHOTO
OF DOC HOLLIDAY?**

\$5.99 • TrueWestMagazine.com



Adoption Opportunities

August 19-20

Swanzey, NH

August 20-21

Grass Valley, CA

August 27 *Trained Yearlings*

Tyler, TX

August 28

Boise, ID

August 28-September 13

Internet Adoption

September 5

Blackfoot, ID

September 9

Canon City, CO

September 10

Riverton, WY

September 14

Salt Lake City, UT

September 23-24

Clemson, SC

October 7-8

Murray, KY

Standard adoption fee for untrained horses is \$125.

Gentled horses are available across the United States through TIP. Adopt a halter-trained mustang or burro for \$125.

Approved TIP trainers can earn \$500-\$800 for gentling a mustang or burro and finding an adopter. Contact the Mustang Heritage Foundation at 512.869.3225 or visit mustangheritagefoundation.org

UNTOUCHED OR GENTLED

There is a wild horse or burro for you

Image by Becky Papa



If you don't see a location near you listed above, please visit **BLM.gov** or call **866.468.7826**

THE BUFFALO SOLDIERS NATIONAL MUSEUM



Exhibit Hours:

M-F: 10:00 a.m. – 5:00 p.m.

Sat: 10:00 a.m. – 4:00 p.m.



What to See:

Step into America's only Museum that solely chronicles the African American Military experiences from the Revolutionary War to the present times. Observe artifacts from the Civil War, WWI and WWII.

Did You Know?

The men in blue were Black: The Buffalo Soldiers were the peacekeepers of the Western Frontier. They encountered warring Indians, bandits, cattle thieves, murderous gunmen, bootleggers, trespassers, and Mexican revolutionaries.

Your Involvement:

Participate in interactive tours, watch a video narrated by Channel 13 Anchor Woman, Ms. Gina Gaston, sit back and enjoy a live, powerful and vivid reenactment of "A Soldier's Story," the life of "Sgt. Tyrrell D. Biggs" in our Henry O. Flipper Theater.

For more information please visit:

www.buffalosoldiermuseum.com or call (713) 942-8920

READY AND FORWARD • WE CAN WE WILL

The Buffalo Soldiers National Museum

3816 Caroline Street / Houston, Texas 77004



MILE HIGH PRESCOTT, ARIZONA

ARIZONA'S ORIGINAL TERRITORIAL CAPITOL

Celebrating

OUR UNIQUE HISTORY & WESTERN HERITAGE

Prescott
ARIZONA VISIT-PRESCOTT.COM



AN ARIZONA HISTORY

Adventure

SOAK IN THE HISTORY OF THE ARIZONA WEST

415 W. GURLEY STREET, PRESCOTT, ARIZONA

928-445-3122

SHARLOT.ORG

CELEBRATING
30 YEARS ART & HERITAGE
OF THE

American West



ART & HERITAGE OF THE AMERICAN WEST
PHIPPEN MUSEUM

4701 N. HIGHWAY 89, PRESCOTT, ARIZONA

928-778-1385

PHIPPENARTMUSEUM.ORG

The
Smoki
MUSEUM



American

INDIAN ART
& CULTURE

147 N. ARIZONA AVE.
PRESCOTT, ARIZONA

928-445-1230

SMOKIMUSEUM.ORG



ROCK ISLAND AUCTION COMPANY.

PRESENTS A *Premiere* FIREARMS *Auction*

THE COLLECTION OF
ROBERT M. LEE PART I

SEPTEMBER 9TH, 10TH & 11TH

FEATURING ICONIC COLLECTIONS:

- The Thor Edgeberg Collection
- The Elven Hamilton Collection
- The Putnam Green/Sycamore Collection
- Arms from Noted Author and Collector Ray Saigo
- Part II of the John H. Bill Collection of Rare European Semi-Automatic Pistols
- The Piedmont Collection of World Class Kentucky Flintlocks and High End European Arms Part III

THE SECOND
INSTALLMENT
OF THE
**ROBERT
BRETHERTON**
COLLECTION

3 DAY LIVE
PUBLIC AUCTION

OVER
2700 LOTS

BUFFALO BILL (WILLIAM F. CODY)



Important and Well Documented Factory Engraved Deluxe Winchester Model 1873 Rifle with Factory Exhibition Special Order Finish and Features Presented by Buffalo Bill (William F. Cody) to Robbie Campbell Adams Twelve Year Old Son of Wild West Show Pamphlets Publisher for the Wild West Shows Performance at Madison Square Garden 1883

Documented Historic Factory Engraved Remington Model 12-B Gallery Special Model Slide Action Rifle Sold to Frank Butler Husband of Famed Exhibition Shooter Annie Oakley



FRANK BUTLER & ANNIE OAKLEY

Exciting Colt Single Action Revolver Documented to Buck Taylor "King of the Cowboys" of Buffalo Bill's Wild West Show

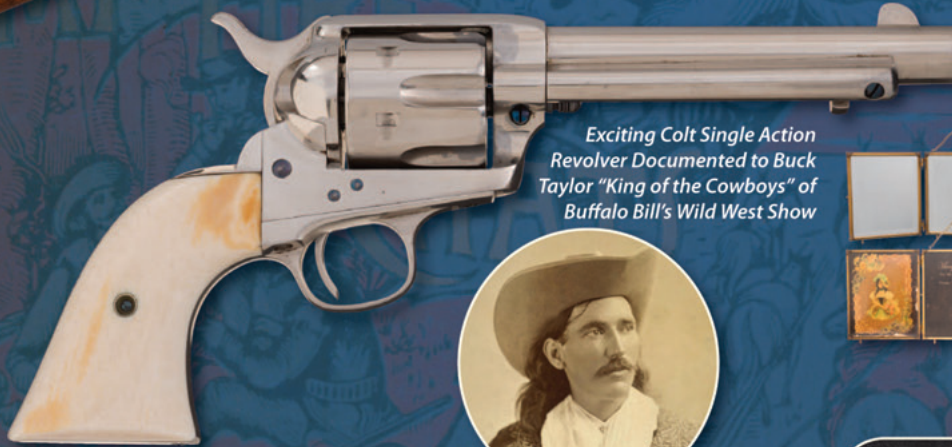

BUCK TAYLOR "KING OF THE COWBOYS"

SEE OUR BACK COVER AD IN THIS ISSUE OF TRUE WEST FOR MORE DETAILS



Merry Christmas
To: My Darling Wife
Louisa
From: "Wm." F. Cody

A tri-fold mirror

A leather briefcase



"Wm." F. Cody
Buffalo Bill - Wild West

Memorabilia Lot Pertaining to Famed Wild West Showman Buffalo Bill



The World Leader for Quality Collectable and Antique Firearms

Full-Color Catalog Online NOW!

To Order Your Full-Color 3-Volume Set
Catalog Call (800) 238-8022 (\$60 Inc. S&H)



WEBSITE: www.rockislandauction.com ADDRESS: 7819 42nd Street West, Rock Island, IL 61201

PHONE: 309-797-1500 or 800-238-8022 FAX: 309-797-1655 EMAIL: info@rockislandauction.com

Fully Licensed Class III Auctioneer CONSIGNMENT CONTACT: Acquisitions Department 800-238-8022 or

Email: guns@rockislandauction.com RIAC is always accepting quality consignments - one gun or an entire collection!

OPENING SHOT

WE TAKE YOU THERE

SA

GENER



SANTA YSABEL,
STORE
GENERAL MERCHANDISE



A Community Gathers

On the road between Ramona and Julian, Santa Ysabel boomed when gold was discovered in 1870 in an area already populated by American Indians and Mexican ranchers. John Curlee built the Santa Ysabel Store in 1884, and soon after, druggist and rancher David Leonard Hoover bought it. The store, preserved by Save Our Heritage Organisation, is the only 19th-century, false-front adobe building in San Diego County, California. Learn more about the group's efforts in *Old West Saviors*.

— COURTESY SAVE OUR HERITAGE ORGANISATION —



True West captures the spirit of the West with authenticity, personality and humor by providing a necessary link from our history to our present.

EDITORIAL

EXECUTIVE EDITOR: Bob Boze Bell

EDITOR: Meghan Saar

EDITORIAL TEAM

Senior Editor: Stuart Rosebrook

Features Editor: Mark Boardman

Copy Editor: Beth Deveny

Firearms Editor: Phil Spangenberg

Westerns Film Editor: Henry C. Parke

Military History Editor: Col. Alan C. Huffines, U.S. Army

Preservation Editor: Jana Bommersbach

Social Media Editor: Rhiannon Deremo

Content Curator: Cameron Douglas

PRODUCTION MANAGER: Robert Ray

ART DIRECTOR: Daniel Harshberger

GRAPHIC DESIGNER: Rebecca Edwards

MAPINATOR EMERITUS: Gus Walker

HISTORICAL CONSULTANT: Paul Hutton

CONTRIBUTING EDITORS

Tom Augherton, Allen Barra, Leo W. Banks, John Beckett,

Terry A. Del Bene, John Boessenecker, Johnny D. Boggs,

Richard H. Dillon, Drew Gomber, Kevin Kibsey,

Dr. Jim Kornberg, Leon Metz, Sherry Monahan,

Candy Moulton, Frederick Nolan, Gary Roberts,

Andy Thomas, Marshall Trimble, Linda Wommack

ARCHIVIST/PROOFREADER: Ron Frieling

PUBLISHER EMERITUS: Robert G. McCubbin

TRUE WEST FOUNDER: Joe Austell Small (1914-1994)

ADVERTISING/BUSINESS

PRESIDENT & CEO: Bob Boze Bell

PUBLISHER & CRO: Ken Amoroso

GENERAL MANAGER: Carole Compton Glenn

ASSOCIATE PUBLISHER: Dave Daiss

SALES & MARKETING DIRECTOR: Ken Amoroso

REGIONAL SALES MANAGERS

Greg Carroll (greg@twmag.com)

Arizona, California, Idaho, Iowa, Kansas,

Nevada & Washington

Cynthia Burke (cynthia@twmag.com)

Montana, New Mexico, North Dakota, Oklahoma,

South Dakota, Utah & Wyoming

Sheri Riley (sheri@twmag.com)

Colorado, Minnesota, Missouri, Nebraska, Oregon,

Tennessee & Texas

ADMINISTRATIVE ASSISTANT: Susan Kulenkamp

September 2016, Vol. 63, #10, Whole #560. True West (ISSN 0041-3615) is published twelve times a year (January, February, March, April, May, June, July, August, September, October, November, December) by True West Publishing, Inc., 6702 E. Cave Creek Rd, Suite #5 Cave Creek, AZ 85331. 480-575-1881. Periodical postage paid at Cave Creek, AZ 85327, and at additional mailing offices. Canadian GST Registration Number R132182866.

Single copies: \$5.99. U.S. subscription rate is \$29.95 per year (12 issues); \$49.95 for two years (24 issues).

POSTMASTER: Please send address change to: True West, P.O. Box 8008, Cave Creek, AZ 85327. Printed in the United States of America. Copyright 2016 by True West Publishing, Inc.

Information provided is for educational or entertainment purposes only. True West Publishing, Inc. assumes no liability or responsibility for any inaccurate, delayed or incomplete information, nor for any actions taken in reliance thereon.

SUBSCRIPTIONS, RENEWALS
AND ADDRESS CHANGES

888-687-1881

FAX: 480-575-1903

Follow us on:



True West Online >

TrueWestMagazine.com

September 2016 Online and Social Media Content



Join the Conversation

"Even into the 1800s, barbers were also dentists. Some also did minor surgeries. I heard the red-and-white swirled barber poles came from when they used to put out their laundry to dry. Some bloody, some clean. Not sure that would lure me in!"

-Ted Hawkins of Oklahoma City, Oklahoma



Go behind the scenes of True West with Bob Boze Bell to see this sketch, *The Wary Walk Down*, and more of the executive editor's Daily Whipouts (Search for "July 05, 2016").

Blog.TrueWestMagazine.com



Edward Curtis took this photograph of Chief Joseph in Seattle, Washington, in 1903, just a year before the Nez Perce leader's death. Find this and more historical photography on our "American Indians" board.

Pinterest.com/TrueWestMag



- COURTESY LIBRARY OF CONGRESS -

- | | | | |
|-----------|------------------------------|------------|-----------------------------------|
| 4 | OPENING SHOT | 52 | SURVIVAL OUT WEST |
| 8 | SHOOTING BACK | 54 | RENEGADE ROADS |
| 9 | TO THE POINT | 60 | FRONTIER FARE |
| 10 | TRUTH BE KNOWN | 62 | WESTERN MOVIES |
| 12 | INVESTIGATING HISTORY | 66 | WESTERN BOOKS |
| 14 | OLD WEST SAVIORS | 74 | TRUE WESTERN TOWNS |
| 16 | COLLECTING THE WEST | 105 | WESTERN ROUNDUP |
| 19 | SHOOTING FROM THE HIP | 110 | ASK THE MARSHALL |
| 44 | CLASSIC GUNFIGHTS | 112 | WHAT HISTORY HAS TAUGHT ME |
| 50 | UNSUNG | | |

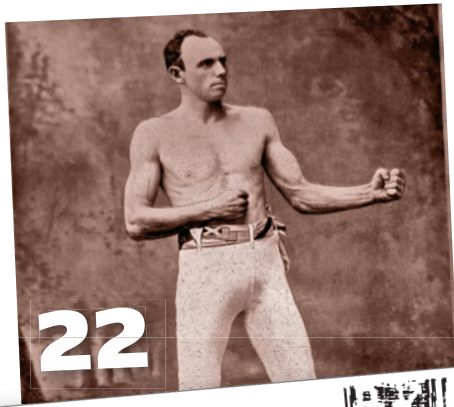

22 THE FIX

A bombshell historical discovery may answer an age-old question that has been a blemish on Wyatt Earp's career.

—By Garner A. Palenske



26 WYATT EARP MYTHBUSTERS

The truth about three enduring Earp legends (including whether or not he and Josie had a relationship in Tombstone).

—By Allen Barra



32 GETTING TO KNOW DOC AND WYATT

Novelist Mary Doria Russell reveals her inspiration for writing about Doc Holliday, Wyatt Earp and the Gunfight Behind the O.K. Corral.

—By Allen Barra



34 NEW DOC PHOTO DISCOVERY?

A museum in Silver City believes Doc Holliday can be seen in a local historical photograph.

—By Leo W. Banks

36 THE WALK DOWN

A fresh and illustrative look at the most famous stroll in American history.

—By Casey Tefertiller

46 BEHAN'S LIES

When Johnny Behan changed his story, he transformed the historical view of the Gunfight Behind the O.K. Corral.

—By Casey Tefertiller

48 THE REEL WALK DOWNS

Our eight favorite film and TV representations of the famous walk down to the lot behind the O.K. Corral.

—By Allen Barra

78 TOP 10 MUSEUMS OF THE WEST 2016

Western history and art at these top museums showcase stories of Western heritage to engage visitors.

—The Editors/Written by Candy Moulton



Cover design by Dan Harshberger/
Courtesy Buena Vista Pictures

THAT'S CRAZY

The first episode of AMC's miniseries *The American West*, a series featured in the August 2016 issue, repeats the common view that Crazy Horse led the decoy party that trapped and killed Capt. William J. Fetterman's entire command near Fort Phil Kearny on December 21, 1866. No known primary source, however, documents the future Lakota war leader's presence at the fight. The producers apparently did not do their homework thoroughly.

Lee & Michele Noyes

Past editors of the CBHMA Battlefield Dispatch



Will Strongheart portrays Crazy Horse in AMC's *The American West* miniseries produced by Robert Redford.

— BY KRIS CONNOR / GETTY IMAGES FOR AMC —

Self-Made Lawman

How refreshing to see New Mexico's most famous "self-made" lawman, Elfego Baca, recognized in your July 2016 *Renegade Roads*. By the turn of the 20th century, Baca was so widely respected in New Mexico that Territorial Gov. Miguel J. Ortega Jr. chose both he and Pat Garrett to escort him onto the floor of the 1900 Republican National Convention. It's to *True West's* credit that you chose to highlight this oft neglected but arguably most important Hispanic lawman of America's frontier period.

Dr. Jeff Schwehn

Las Cruces, New Mexico

I enjoyed Johnny D. Boggs's article on Elfego Baca. I am reminded of a story about him that I once heard, but cannot vouch for its accuracy. One of Baca's more wealthy clients, arrested in El Paso, Texas, telegraphed Baca stating, "Come quickly—I am accused of murder." Lawyer Baca wired back, "I am leaving at once—and bringing three eye witnesses."

Robert Rybolt

Hanover, Kansas

Doc's Everywhere

I've got a tintype photo I believe is of John Henry "Doc" Holliday. From my research, I believe it could be part of oilman Frank Phillips' lost collection, bought from a Checotah antique store. Take a look.

Dale Virden

Bartlesville, Oklahoma

Another Doc

Great new issue [July 2016]; loved the Buffalo Soldiers article and, of course, Jim Kornberg's article on William "Doc" Rowan, the first ER of the Ouray Elks Lodge in Colorado. I'll congratulate him the next time I see him. Great to see the Ouray Elks Lodge on p. 47. I'm a two-time Past Exalter Ruler at this lodge, and (coincidence) my wife is also one. She is originally from Bisbee, Arizona, the site of the bear photo on p. 46—small world!

Also, George Marlow (of the famous Marlow Brothers, one of my research specialties) was a member of the Ouray lodge; he joined in 1903. He and brother Charlie moved to the Ridgway area after the vigilante shoot-out in Texas.

Jim Pettengill

Ridgway, Colorado



Lydia Schofield and her brother pose as Ben "Tall Texan" Kilpatrick and Harvey "Kid Curry" Logan, respectively, in the famous Butch Cassidy & Sundance Kid photo cutout at the Wyoming Territorial Prison in Laramie. Writing under the pen name JoJo Thoreau, 11-year-old Lydia became the youngest recipient awarded the Spur, for her children's book *Buckaroo Bobbie Sue*, by Western Writers of America at the annual conference, held this June in Cheyenne.

— BY TIFFANY SCHOFIELD —

BUFFALO SOLDIERS ON TOUR

Just wanted you to know how much I'm enjoying paging through my latest *True West* and reading about the Buffalo Soldiers [July 2016]. While much more should have been said much earlier regarding the service these Army units rendered, you certainly have done your part in bringing that oversight to an end. I take my hat off to all those troopers for their sacrifice to their country. Congratulations for so many well-written articles and never-before-seen photos that bring history into our view.

Bill Dunn

High River Town, Alberta, Canada

Executive Editor Bob Boze Bell writes: *Thanks. We worked hard on that one. And big thanks to author John P. Langellier. If he gets up to your neck of the woods on his Border-to-Border Tour, check him out. You won't regret it.*

Oops!

In August's "Rail Barons, Train Palaces, and Great Locomotives," the following image of the Cumbres & Toltec Scenic Railroad was supposed to appear on p. 84. Our apologies for the inadvertent use of an image from another branch of the historic D&RGW Railroad. Also, in the caption, Chalma should be Chama.

The Cumbres & Toltec Scenic Railroad train and depot in Antonito, Colorado.

— COURTESY DENISE CHAMBERS/MILES COLORADO TOURISM —



Wyatt Earp Captures Renegades

Seeking the truth about that legendary stroll while taking my own stroll on the boardwalks of Tombstone.

On the evening of May 26, 1995, I got into it with a notorious bounty hunter in the Crystal Palace Saloon in Tombstone, Arizona. No blood flowed, but words were exchanged out on the boardwalk in front of Campbell & Hatch's Saloon on Allen Street. The next day, me and my pards—The Renegades—posed for a photo on the exact spot where the semi-altercation happened.

Believe it or not, the photographer is Wyatt Earp. No, really. He's a descendant of the real Wyatt Earp whose real name is also Wyatt Earp. He was doing a show in Tombstone and happened to be walking by, and when I asked him to take the photo, he did.

Nearly every person in this photo contributed to the magazine you are holding in your hands. A couple of the dudes practically wrote the whole dang issue.

Allen Barra is a prolific writer who has written for *The New York Times* and *Newsday*, and he's the author of *Inventing Wyatt Earp*. Allen interviewed the brilliant writer Mary Doria Russell, p. 32, and he wrote the Mythbusters piece on Wyatt Earp, p. 26, and "The Reel Walk Downs" article, p. 48. Meanwhile, not to be outdone, Casey Tefertiller, the author of what many consider the definitive bio, *Wyatt Earp: The Life Behind the Legend*, let loose with "The Walk Down" cover story, p. 36, and "Behan's Lies," p. 46.

In 2006, I met Joaquin Jackson and later, someone asked me what it was like meeting the legendary Texas Ranger. I said, "I felt like I had just met Wyatt Earp." A tribute to Joaquin, by his friend Mike Cox, appears on p. 72. We'll miss you, pard.

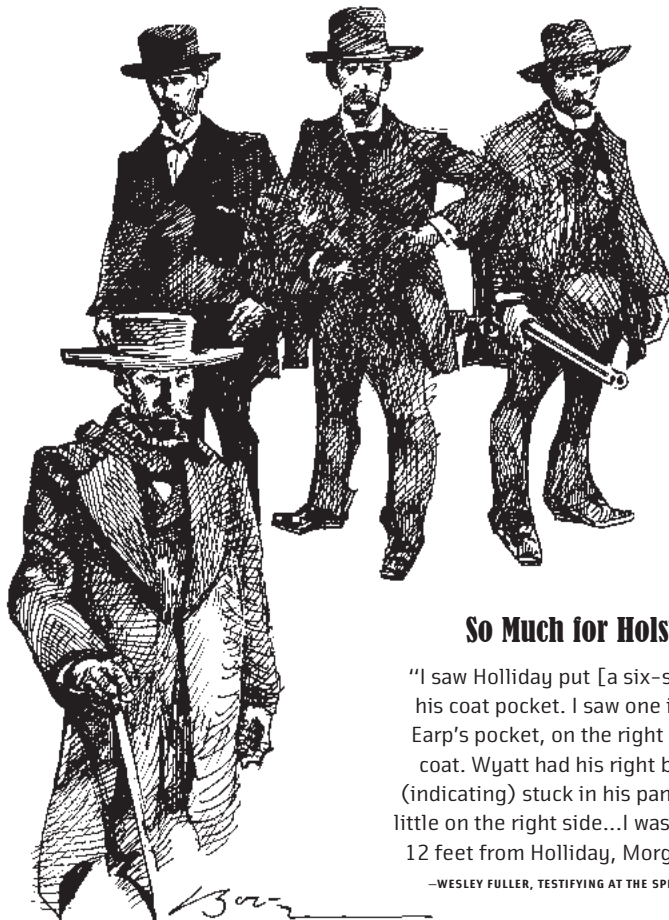

So Much for Holsters

"I saw Holliday put [a six-shooter] in his coat pocket. I saw one in Morgan Earp's pocket, on the right side of his coat. Wyatt had his right back here, (indicating) stuck in his pants. I think a little on the right side...I was about 10 or 12 feet from Holliday, Morg and Virg."

—WESLEY FULLER, TESTIFYING AT THE SPICER HEARING



The Renegades: (Back row, from left) Robert G. McCubbin, James Dunham, Robert Palmquist and Jeff Morey. (Kneeling, from left) Allen Barra, Paul Northrop, Casey Tefertiller and me.

—TRUE WEST ARCHIVES—



For a behind-the-scenes look at running this magazine, check out BBB's daily blog at TWMag.com

Quotes

"It has never been my object to record my dreams, just the determination to realize them."

– Man Ray, American artist

"As a child my family's menu consisted of two choices: take it or leave it."

– Buddy Hackett, American actor

"...I learned the lesson that great men cultivate love, and that only little men cherish a spirit of hatred."

– Booker T. Washington, American educator

"No, wilderness is not a luxury but a necessity of the human spirit, and as vital to our lives as water and good bread."

– Edward Abbey, American author

"If you are playing bad you are going to lose here, on clay, on ice or on the beach."

– Rafael Nadal, Spanish tennis player, before the 2006 U.S. Open

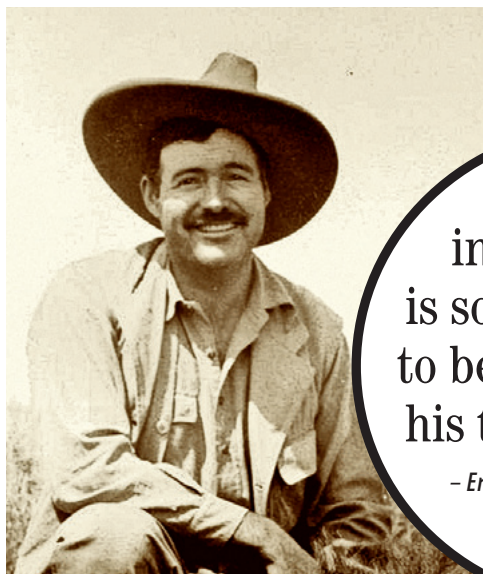

– TRUE WEST ARCHIVES –

"...an intelligent man is sometimes forced to be drunk to spend his time with fools."

– Ernest Hemingway, Nobel Prize-winning American author

Bizarro BY DAN PIRARO



"If I had heard that score, I think I would have ridden my horse differently."

– Eli Wallach, actor in 1960's *The Magnificent Seven*, talking about Elmer Bernstein's musical score



Old Vaquero Saying



"Dancing is a perpendicular expression of a horizontal desire."

NORTHERN ARAPAHO EXPERIENCE™

CULTURAL ROOM

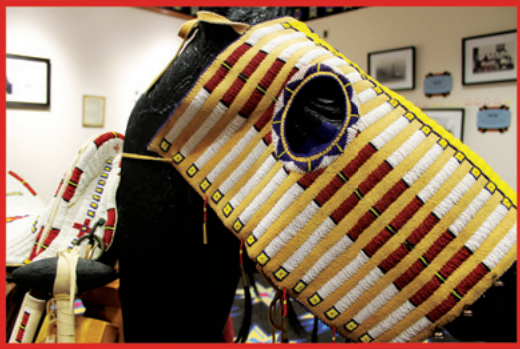

STEP INTO THE WORLD OF THE NORTHERN ARAPAHO PEOPLE!

Located in the hotel lobby of the Wind River Hotel and Casino, the Northern Arapaho Experience Cultural Room tells the story of the Arapaho Tribe through storytelling, paintings, artifacts and photographs. With an Arapaho elder as your guide, visitors can explore and learn in an intimate and serene setting. Visit the Northern Arapaho Experience Cultural Room today and see an up-close and personal view of one of the largest tribes in Wyoming.



PLATINUM RATED HOTEL • CONVENTION SPACE

ADVENTURE PACKAGES Whitewater Rafting • Golf • Dino Dig & More

JOIN THE FUN Blackjack • Poker • Roulette • Over 800 Slot Machines • 3 Restaurants • 2 Gift Shops

hotel reservations [1.866.657.1604](tel:18666571604)

go WindRiverHotelCasino.com

visit 10269 HWY 789 • Riverton, WY

BY MARK BOARDMAN

Jesse James Tastes Blood

A teenager notched his first victims at the Centralia Massacre.

Jesse James had just turned 17 when the opportunity for violence first arose—up close and personal.

He and his older brother, Frank, were riding through Missouri with Confederate guerrilla leader William “Bloody Bill” Anderson, and they were in a foul mood. They had lost 13 men in battle on September 24, 1864. That same day, Union troops executed and scalped six of Anderson’s troops captured the day before. Anderson wanted revenge. He got it on September 27.

That morning, some 80 rebels attacked the tiny village of Centralia, about midway between St. Louis and Kansas City. They ransacked the town, threatened civilians and got drunk. After robbing a stage, the men stopped a train approaching Centralia.

The raiders were surprised to find 24 unarmed Union soldiers on board, veterans of Gen. William Tecumseh Sherman’s Atlanta campaign, headed for home. When two refused to leave the train, Anderson shot them dead. Except for Sgt. Thomas Goodman, who the rebels held as a hostage, the others stripped naked as ordered—and were gunned down. Those not killed during the volley had their throats cut or heads bashed in by rifle butts. The angry men mutilated or scalped several bodies.

The raiders went back to robbing the passengers, including Confederate sympathizers, and killed two more who weren’t quick enough to hand over the loot.

History does not record if the James boys participated in the raid. But in what followed, they almost certainly got their hands bloody.



That same afternoon, Union Maj. A.V.E. Johnston led nearly 160 men of the 39th Missouri, mainly recruits with little or no

Jesse and Frank learned lessons they would practice for the next 18 years.

battle experience, after the 80 tough, seasoned veterans, who were joined by dozens more from the Centralia area. When Johnston ordered his men to dismount, the Confederates charged them on horseback. A Union volley took down some of Anderson’s men, but the rest overran their

foes. Frank claimed Jesse fired the pistol shot that killed Johnston.

The James boys joined the rebels in killing anyone they caught, including soldiers trying to surrender. Of the force, 123 died.

The victory celebration, featuring whiskey, trophy scalps and loot from the



Jesse James (left) got his hands bloody at the tender age of 17 in 1864. He learned how to be public menace from his mentor, William “Bloody Bill” Anderson (above), who did not survive their trail of vengeance.

— JAMES PHOTO COURTESY ROBERT G. MCCUBBIN COLLECTION; ANDERSON PHOTO TRUE WEST ARCHIVES —

bodies, lasted about three hours. Then Anderson ordered his men to march, knowing that Union troops would be on the way, to exact their own revenge.

In the aftermath, Sgt. Goodman—the lone survivor of the troops taken from the train—escaped about 10 days later. For Anderson, Centralia was his swan song; less than a month later, on October 26, he was killed in a battle near Richmond, and his troops splintered. Jesse and Frank learned lessons about killing, robbing and looting that they would practice for the next 18 years.

After Centralia, a neighbor asked Jesse and Frank’s mother, Zerelda Samuel, if she was ashamed by their actions. She said she was not—and that she prayed to God to protect them in their work. ✦



Native American



Fine Art



Prehistoric



Civil War

ANCIENT OZARKS NATURAL HISTORY MUSEUM

FEATURING THE MOST SIGNIFICANT COLLECTION OF NATIVE AMERICAN ARTIFACTS EVER ASSEMBLED

— AT BIG CEDAR LODGE —

Located in the heart of the Missouri Ozark Mountains, the Ancient Ozarks Natural History Museum at Big Cedar Lodge was created to celebrate the fascinating history and stunning natural beauty of the region. Created by Johnny Morris, founder of Bass Pro Shops, and driven by his commitment to conservation and preservation, this subterranean adventure walks you through the chronological development of the Ozarks. Featuring prehistoric skeletal remains, extensive Civil War displays, and the foremost collection of Native American artifacts, you can learn about the important role that Missouri and the Ozarks played in shaping the American west. Explore the natural beauty of the region by booking a private, lakeside cabin or room in a grand lodge at Big Cedar Lodge. Call today to discover all of the Ozark adventures that await!

BIGCEDAR.COM



800.225.6343

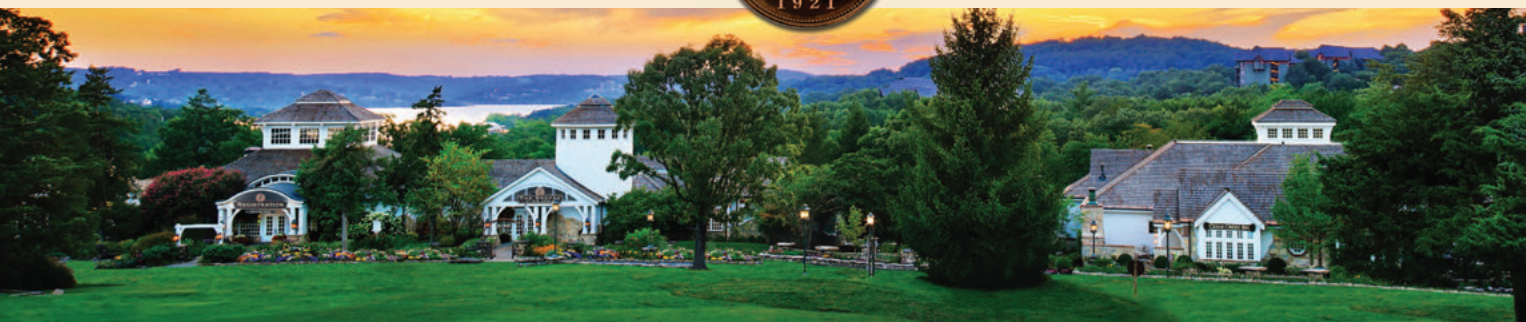

BY JANA BOMMERSBACH

A Barn Worth Saving

A group of San Diegans preserve another forgotten piece of California history.



Bob McDaniel had the good fortune of knowing he helped saved a historic barn before he died, at the age of 86, this February. David Leonard Hoover's barn, shown circa 1890s, will house the Save Our Heritage Organisation's historic vehicles, such as the Concord stage, shown in inset, with (from left) Bruce Coons, his wife, Alana, and stagecoach builder Jim Jensen. Next to the barn, you can see the 1884 Santa Ysabel Store in the background. Turn to *Opening Shot* for a closer look.

— COURTESY SAVE OUR HERITAGE ORGANISATION —

“So, you're the people who save things.”

Bob McDaniel was looking for exactly those kind of people because this lifelong resident of Santa Ysabel, California, was on a mission to save a barn.

Not just any barn, but the Dutch-style redwood Hoover Barn that had been a fixture in San Diego County's backcountry since 1890.

Yes, Bruce Coons said, he was one of those people, and he was “shocked” at the letter McDaniel pulled out of his pocket.

Coons is executive director of California's oldest continuous preservation group—Save Our Heritage Organisation, which began in 1969—and at that moment in 2011, he was still celebrating the group's latest purchase. They had closed the deal to buy and restore the Santa Ysabel Store, originally owned by David Leonard Hoover and once the end-all-and-be-all for the agricultural area that had begun as a Mexican land grant in 1844.

Coons had big ideas for the 1884 store. “This store had been cut up like swiss cheese over the years,” he says. The first job was to return it to its 1800s splendor. It would then resume its old life, this time with heirloom and artisanal food and gifts and books for naturalists and cultural tourists.

But here, just a few days after they sealed that deal, was a town neighbor showing Coons a letter from the county declaring that the Hoover Barn next door was about to be burned to the ground.

“The barn had been used by the agricultural department, with pesticides mixed and used out of here, and the county decided it was a nuisance,” Coons says. He called the county to stop the burn.

Coons found out that the county did not realize the barn was historic, and officials agreed to fund a study to see if the barn was worth preserving. The answer was yes; the Hoover barn was eligible to

be listed on the National Register of Historic Places.

“This is one of the few very large 19th-century barns left,” Coons says. “We've lost the rest to development and backcountry fires.”

The one-and-a-half-story, wooden H-frame barn has four bays that were divided into horse stalls and storage space for carriages and harvesting machinery.

“It's a landmark for this beautiful, oak-studded valley,” Coons says. “You come over the hill, and you can't miss the barn.”

The county agreed to clean up any pesticide residue and sell the barn for \$30,000. The deal was finalized in October 2015. By the end of this year, Coons expects the barn to be restored—to the tune of \$100,000—and ready to join the store in revitalizing Santa Ysabel.

The barn will house historic vehicles, like the heritage group's Concord stage, which is used for public stagecoach rides and special events such as festivals, antique shows and weddings. And its 126 years of service to the community will continue. ✦

Arizona's Journalist of the Year, **Jana Bombersbach** has won an Emmy and two Lifetime Achievement Awards. She also cowrote and appeared on the Emmy-winning *Outrageous Arizona* and has written two true crime books, a children's book and the historical novel *Cattle Kate*.

FOR A NEW LOOK AT THE OLD WEST

In 1881 *The Tombstone Epitaph* reported the Gunfight at the O.K. Corral. Today, Wyatt Earp and Doc Holliday live on in *The Tombstone Epitaph*, now an historical monthly journal of the Old West still published in Tombstone, AZ.

Twenty pages of newly researched articles on the winning of the Old West every month:

- HISTORIC EVENTS
- FRONTIERSMAN & GUNSLINGERS
- THE FAMOUS & THE INFAMOUS
- COWBOYS & INDIANS
- PIONEER WOMEN & FAMILIES
- RARE PHOTOGRAPHS



Send this coupon with your subscription to get a FREE reprint of the 1881 Epitaph reporting the Gunfight at the O.K. Corral®. Or subscribe online at www.tombstoneepitaph.com

ONLY \$25 PER YEAR

The Tombstone Epitaph.

Name _____

Address _____

City _____ State _____ Zip _____

Send check or money order to: The Tombstone Epitaph
P.O. Box 1880, Tombstone, AZ 85638.

Rates U.S.: 1-Year \$25 2-Year \$45 3-Year \$60



FAMOUS GUNFIGHT SITE

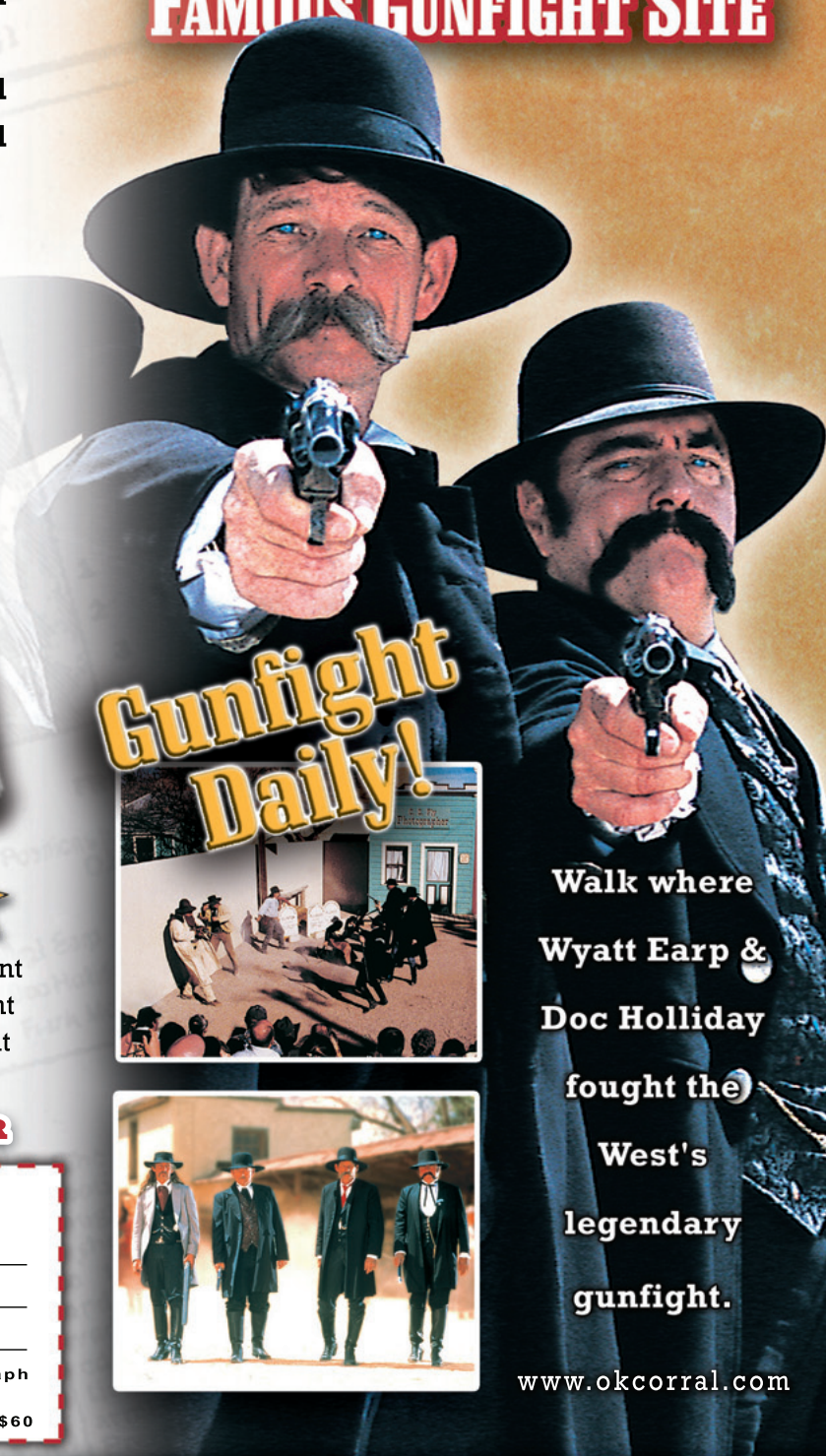

Gunfight Daily!



Walk where
Wyatt Earp &
Doc Holliday
fought the
West's
legendary
gunfight.

www.okcorral.com

TOMBSTONE, ARIZONA

Sixty-five Miles S.E. of Tucson

BY MEGHAN SAAR

Tombstone Jackpot

Collectors took home historic ephemera tied to the Wild West's most famous gunfight.

The most famous gunfight of the Wild West era took place on the streets of Tombstone, Arizona Territory, on October 26, 1881. Over the past 135 years, written or printed materials with links to the famous shoot-out have miraculously survived the dust bins where such relics are usually relegated after their short-term usefulness.

Collectors cashed in on the opportunity to purchase some of this ephemera at Heritage Auctions' "Legends of the West" sale in Dallas, Texas, on June 11. Featured here are the top-selling gunfight-related pieces of paper amazingly preserved for gunfight aficionados to relish and save for generations to come.



UPCOMING AUCTIONS

September 3, 2016

Western Art

Heart of the West (Coeur d'Alene, ID)
HeartofTheWestArt.com • 406-781-0550

September 15, 2016

Rare Books

Heritage Auctions (Dallas, TX)
HA.com • 877-437-4824

Please note: The top lot for this auction was a gun belt reportedly worn by "Buckskin Frank" Leslie. This artifact will be shared in a future issue.

Earp signatures are rare, which explains why this city license was the auction's top-selling lot that had ties to the famous Tombstone gunfight. Virgil Earp (right) signed the back of the brothel license for Madam Emma Parker, issued about a month before the O.K. Corral gunfight, on September 14, 1881, and denied for lack of payment six days later; \$9,500.

After Newton "Old Man" Clanton (right) was killed at Guadalupe Canyon on August 13, 1881, a survivor of that ambush, Billy Byers, was given this photo from sons Phin and Ike (far right). Byers may have inscribed the "Clanton" on this photograph, as the signatures do not appear to match Ike's or Phin's.

— NEWMAN PHOTO COURTESY ROBERT G. MCCUBBIN COLLECTION; HISTORICAL PHOTOS TRUE WEST ARCHIVES —

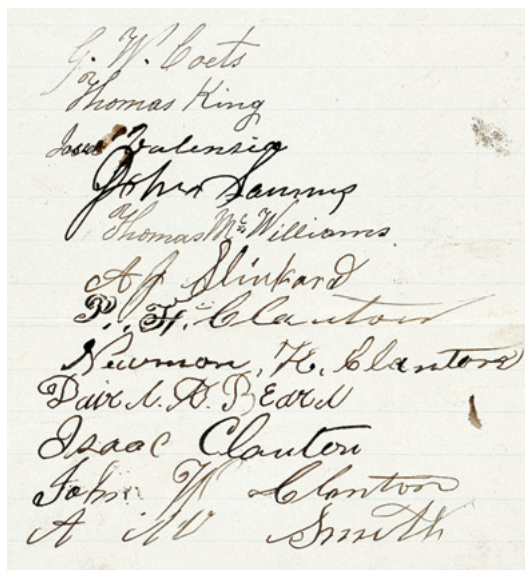

The Clanton clan established Clantonville on the Gila River and successfully petitioned, on June 12, 1874, for the precinct to be approved, with Newman Haynes "Old Man" Clanton as justice of the peace. Signatures on the petition include the patriarch's as well as those of his sons, Isaac, John and Phin (P.H.). When the town did not bring a desired fortune, the cowboys moved on to earn fame as rustlers who attracted the wrath of the law; \$6,500.

— ALL AUCTION IMAGES COURTESY HERITAGE AUCTIONS —

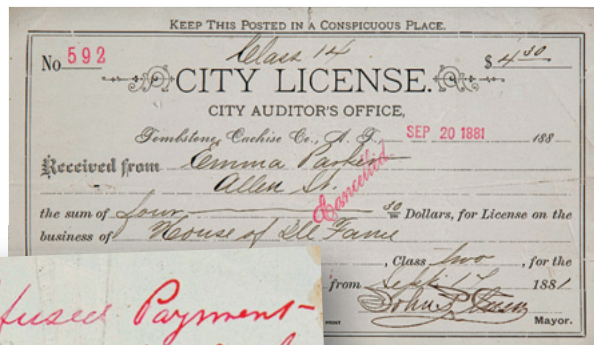
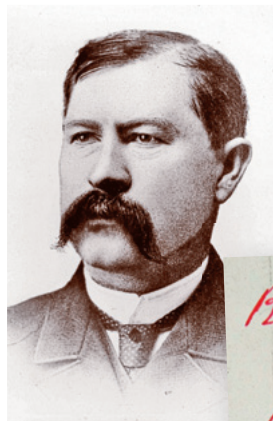

*Refused Payment -
Virgil Earp
City Tax Collector*

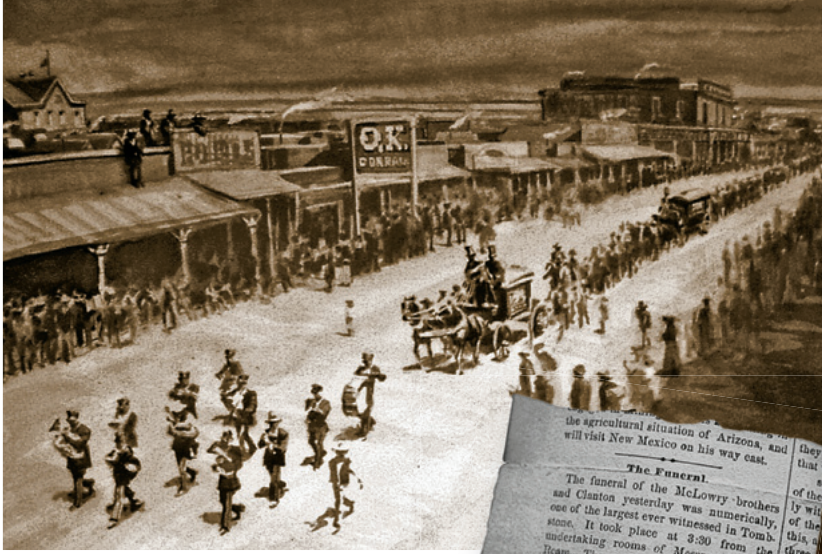

Sandy Bob's stage earned some extra special notoriety when the passenger departures were listed beneath the funeral notice for the McLauri brothers and Billy Clanton. The funeral was "one of the largest ever witnessed in Tombstone" and a "most impressive and saddening sight...to be hoped may never occur again in this community."

- FUNERAL ILLUSTRATION BY BOB BOZE BELL -

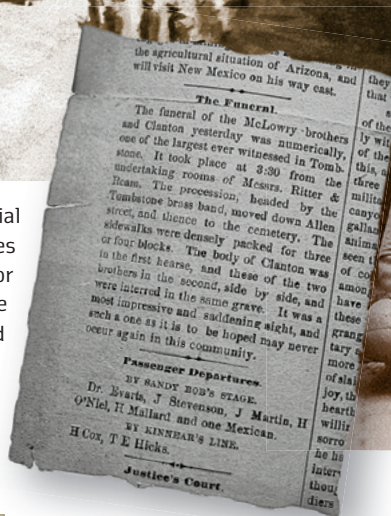

Robert "Sandy Bob" Crouch made his first stagecoach run in Arizona Territory on June 21, 1880, the day the railroad auctioned off town lots for Benson. Crouch ran his stage line out of Tombstone until 1887, when he sold his company. This "Sandy Bob" ticket to Contention City dates between those years; \$2,400. He's shown here as one of the baseball nines for the Tombstone Tigers.

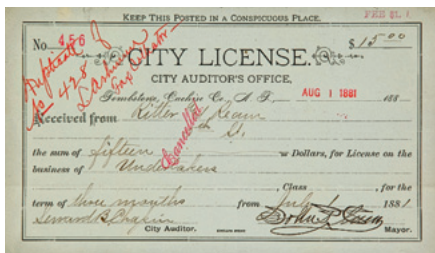

The afternoon of the gunfight on October 26, 1881, the McLaurys and Clantons purchased their ammunition at George Spangenberg's gun shop. The Tombstone gun dealer signed this receipt two months prior, on August 30; \$1,000.

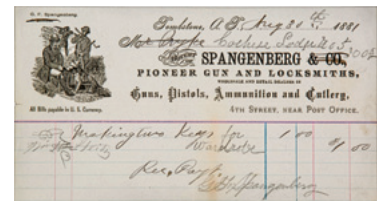

The summer before the famous gunfight, on August 1, this business license was issued to Andrew Jackson Ritter and W.H. Ream. Ritter prepared the bodies of the cowboys (inset, from left), Tom and Frank McLauri and Billy Clanton, after they were killed behind the O.K. Corral; \$1,700.



The same day of the O.K. Corral shoot-out, a teller stamped this bank draft payable to Hawkins, Boorman & Company, wholesale dealers in wines, liquors, oils and cigars; \$1,700.

George E. Goodfellow requests the city of Tombstone appoint him health officer in this letter written on February 7, 1881. That winter, the doc's testimony at the Spicer Hearing aided the Earp brothers in gaining a murder acquittal for their roles in the O.K. Corral gunfight. The doctor is shown riding El Rosillo, a gift he received after he aided survivors of an 1887 earthquake that struck Sonora, Mexico; \$1,200.

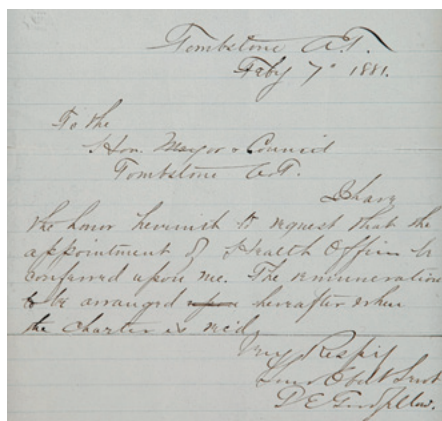

The Smoke Wagon™

Short-Stroke Option



Calibers



*You gonna skin that Smoke Wagon™
or just sit there and read?*

Grips



Standard

Birdsheep

Gunfighter

Barrel Lengths

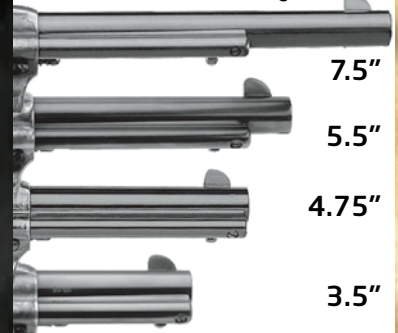

7.5"

5.5"

4.75"

3.5"

Finishes



Blue / Case
Hardened



Antique



Nickel



Stainless



Engraved

* Not all features available on all models. Please visit TaylorsFirearms.com for available configurations.

info@taylorsfirearms.com taylorsfirearms.com
304 Lenoir Drive Winchester, VA 22603
P:540-722-2017



TAYLOR'S & COMPANY
Keeping the Legend Alive

The Shoots Far Gun

Some modern firearms "experts" argue that the Sharps Big Fifty rifle couldn't have made Billy Dixon's famous nearly-mile-long shot. Wanna bet?

American Indians called the Sharps buffalo rifle the "Shoots Far Gun," or the gun that "shoots today and kills tomorrow," and for good reason. In the hide-hunting years of the 1870s, the heavy Sharps rifle was the "buffalo gun" of choice with many hide men. While they made most of their shots at around 200 yards or less, the savvy buffalo hunters realized that when hunting in Indian country, they should keep about 10 cartridges set aside for self-defense. With these few rounds, they were able to keep hostile tribesmen at a safe distance from their bows and arrows and many of their firearms, until they made it back to camp.

A well-recorded example of the Sharps' great range was during the June 1874 Battle of Adobe Walls in the Texas Panhandle, when a group of Indians rode out on a bluff nearly a mile distant from the hunters to survey the

Billy Dixon's famous 1,538-yard shot, taken with a borrowed "Big Fifty" Sharps at the 1874 Battle of Adobe Walls in the Texas Panhandle, has often been disputed, despite being carefully measured by the U.S. Army shortly after the battle. Many modern shooters still can't believe a black powder Sharps rifle could reach out that far. Modern electronic equipment has proved it could do that and much more.

— PORTRAIT BY JOHN ELLIOT JENKINS,
COURTESY PANHANDLE
PLAINS MUSEUM —

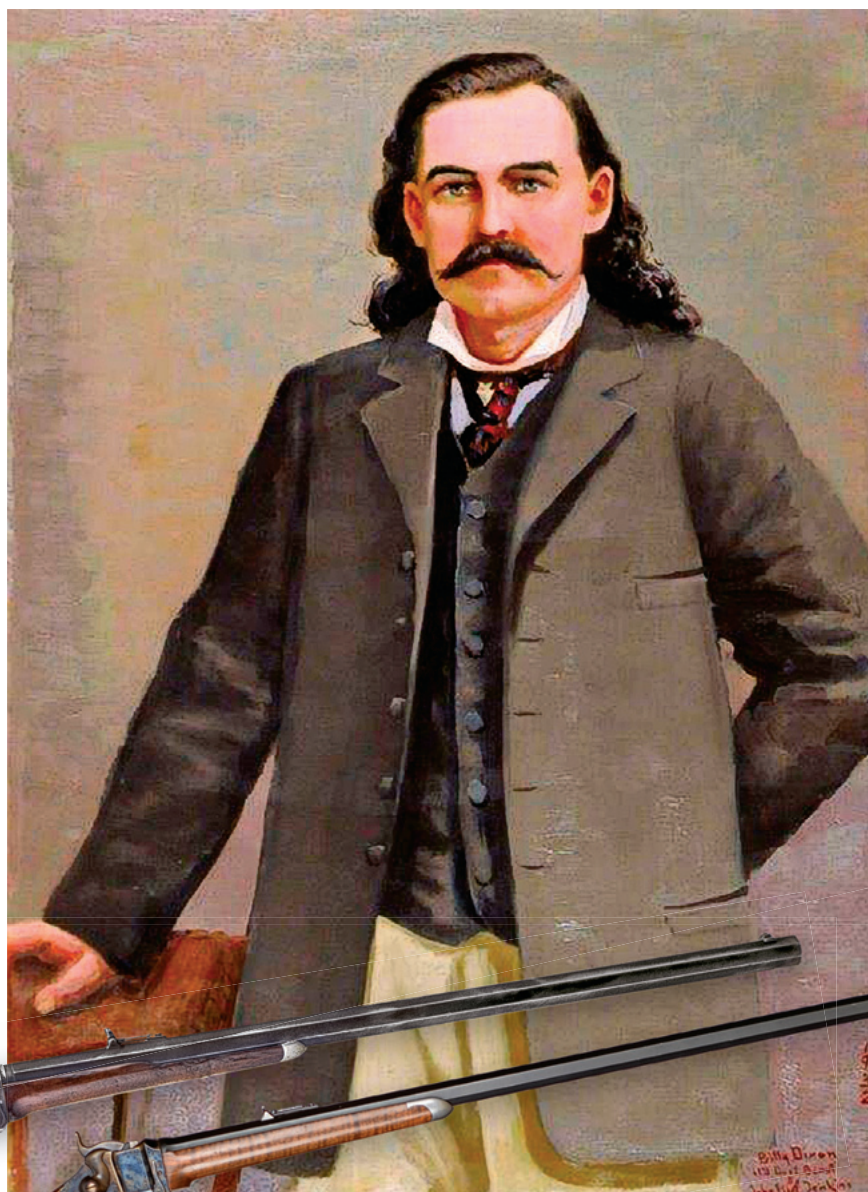

Buffalo hunter Billy Dixon made his famous 9/10ths of a mile shot using an 1874 Sharps rifle in .50-90 caliber, much like this (top) 1872-manufactured, Hartford-made Sharps .44-77 Sporting Model. Later interviews with American Indian survivors of the Adobe Walls fight revealed that although Dixon's shot did not kill the Indian, he was badly wounded, demoralizing the warriors so that they retreated. The author used this (above) .50-90 Shiloh Sharps rifle successfully on many hunts and experimented on his own, making shots at distances similar to Dixon's.

— COURTESY PHIL SPANGENBERGER COLLECTION —

Western Trappings on The Llano



**International Juried
Exhibition & Sale**
Finest in Custom Gear &
Original Western Art

**October 7, 2016
thru
November 19, 2016**



Meet the Artist

Reception & Preview Sale
October 7, 2016
Ticketed Event

Cowboy Breakfast

October 8, 2016
8:00a.m.-10:00a.m.



Exhibit Opening

October 8, 2016
9:00a.m.

No Admission Charge

Museum Benefit Auction

of Western Art and Custom Gear
October 8, 2016
6:00p.m.



www.WesternTrappings.com



This John Eliot Jenkins 1934 painting, *Adobe Walls, 1874*, shows what Adobe Walls, with its adobe and picket-pole buildings, looked like before the attack on June 27, 1874. The defenders, 28 men and one woman, took shelter in two stores and a saloon when an estimated 700-plus Comanche, Kiowa, Cheyenne and Arapaho painted and mounted warriors besieged them.

— COURTESY PANHANDLE PLAINS MUSEUM —

situation. Billy Dixon, who was already well known as a crack shot, was persuaded to try firing at them. He took aim at one with a “Big Fifty” Sharps, borrowed from one of the other hunters, and cleanly dropped a warrior from atop his horse, thus ending the fight. It measured at 1,538 yards!

Although Dixon himself claimed it was a “scratch shot,” many modern shooters try to debunk his shot. Among modern-day nonbelievers was a forensic scientist who claimed a .50-90 Sharps could not throw a bullet out that far. In response to this technician’s curiosity and disbelief, in the fall of 1992, fellow gun writer and long-time amigo Mike Venturino was invited, along with the folks from Shiloh Sharps Rifle Manufacturing Company, to travel to the Yuma Proving Grounds in Arizona, to use some then-newly declassified radar devices to test the performance of several types of ammunition.

Using a machine rest modified from a gun carrier from a Russian T-72 tank, they started firing away. For the first Sharps shot, with the gun carriage elevated to 35 degrees, a 675-grain bullet, pushed by 90 grains of FFg black powder, and with a muzzle velocity (mv) of only 1,216 feet per second (fps) launched the bullet over 3,600 yards distant. That’s 10,800 feet—over two miles! The scientists couldn’t believe it, so a second round was touched off. This time the lead projectile weighed 650 grains with a mv of 1,301

fps. Using the same 35-degree elevation, the bullet landed 3,245 yards away. When one of the mathematicians calculated some data he suggested they reduce the elevation to about 4½ to 5 degrees to duplicate Billy Dixon’s shot. When this was done using the same load, the lead slug landed 1,517 yards downrange—almost the exact range of Dixon’s controversial shot. A five-degree muzzle elevation can easily be achieved with only the rear barrel sight on a Shiloh Sharps. This writer has made similar long-range shots with his own .50-90 Shiloh Sharps, using 90 grains of FFg black powder and a 515-grain bullet, while testing firearms for *Guns & Ammo* magazine.



This lineup of frontier-era cartridges offers an idea of the size of a .50-90 Sharps round, also known as the “Big Fifty,” shown at far right, compared to (left to right) a .22 Long Rifle, .44-40, and a .45-70 cartridge.

— PHIL SPANGENBERGER —

According to Venturino, with 35 degrees elevation, the bullet gained a maximum height just short of 4,000 feet and was airborne a full 30 seconds. In my own experimentation with my Big Fifty Shiloh Sharps at similar distances, I found that with the slight muzzle elevation of around five degrees, I counted three full seconds between firing the shot and seeing the bullet kick up dirt in the target area. So the next time some modern gun “expert” wagers that you can’t put a bullet a mile out with a Sharps buffalo gun—take the bet! ❖

Phil Spangenberg has written for *Guns & Ammo*, appears on the History Channel and other documentary networks, produces Wild West shows, is a Hollywood gun coach and character actor, and is *True West*'s Firearms Editor.



PHIL SPANGENBERG

SPORTLOCK™ GUN CASES

If you're looking for a protective gun case for your long guns, like a Sharps buffalo rifle, shotgun, scoped rifle, or any longarm, Birchwood Casey's new line of SportLock Soft Gun Cases (52-inch shotgun case shown) offers solid protection when a bulky hard case isn't needed. These handsome Cordura cases are heavily padded for maximum protection with a quilted microfleece liner, and an external zippered pocket for ammo or small accessories, and come in a variety of colors including A-TACS camo. They even have a floating model for waterfowlers. Cases are available in a variety of styles and sizes, including pistol cases.

BirchwoodCasey.com



A. Uberti
HISTORY REPEATS ITSELF



1873 CATTLEMAN II BRASS
Case-hardened, walnut grip
.45 Long Colt, .44-40 or .357 Mag.
3 barrel lengths available



Uberti's Exclusive Retractable Firing Pin

Hammer at rest: firing pin floats free within the hammer, exerts no pressure toward primer.

Hammer cocked: trigger sear ready to engage the firing pin through the internal connector rod.

Trigger pulled: sear pushes the connector rod upward, locks the firing pin forward for firing.

AUTHENTIC INNOVATION

SINCE 1959

How does a single-action revolver meet today's safety standards without compromising its historical looks? It took Uberti's unmatched experience to solve this 150-year-old dilemma. New Uberti Cattleman II: authentic innovation.

Find us on  Facebook

Uberti.com

BY GARNER A. PALENSKE

A BOMBSHELL HISTORICAL DISCOVERY MAY ANSWER AN AGE-OLD QUESTION THAT HAS BEEN A BLEMISH ON WYATT EARP'S CAREER.

The Fix

For more than a century, the Thomas Sharkey versus Robert Fitzsimmons fight of 1896 has been an ugly blemish on the complexion of Wyatt Earp. Dozens of historians have argued both sides of the story: Earp threw the fight, or the foul was a correct call. Finally, in a recently discovered newspaper article, Earp himself explains what happened.

In April 1897, Earp befriended Tom Sharkey and, according to newspaper accounts, would serve as his corner man at the upcoming Sharkey versus Peter Maher fight. Yet Earp was not in Sharkey's corner during the fight as the newspapers had projected. Prior to the fight, Earp sensed the contest was going to be anything but fair. Earp returned to San Francisco, California, on June 4, five days before the fight. Upon arrival, he told *The Los Angeles Times* that the

event was fixed, and "that the fight had been arranged for Sharkey to win on the same principal as Sharkey's fight with Fitzsimmons." What a bombshell! So how does his statement fit into both fights?

THE SAILOR FOUGHT FOUL

On December 2, 1896, Earp refereed the Tom "Sailor" Sharkey versus Robert "Ruby" Fitzsimmons world heavyweight championship fight at Mechanics' Arena in San Francisco. The fight turned out to be the most humiliating event of Earp's life. He was caught wearing a handgun while entering the ring and was

EARP SAYS IT'S FIXED.

SAN FRANCISCO, June 4—[Special Dispatch.] Wyatt Earp, who arrived tonight from the East, is given as authority for the statement that the fight has been arranged for Sharkey to win, on the same principle as Sharkey's fight with Fitzsimmons. The sports, however, who know Maher, put no faith in this story, as Maher is very ambitious to meet Fitzsimmons, and were he beaten by Sharkey he would have no show of meeting the champion.

Have we finally solved the historical debate over Wyatt Earp's referee fiasco? In this newly discovered interview, published in *The Los Angeles Times* on June 5, 1897, the famous frontier lawman admitted the fix was in for Sharkey-Maher just like it had been for Sharkey-Fitzsimmons.

— PUBLISHED IN THE LOS ANGELES TIMES, JUNE 5, 1897 —

The swindlers are on the run, reported *The San Francisco Call* on December 10, 1896. Cops wielding their sticks of "honesty" and "decency" chase after "Foul Earp" and Andy "Long Green" Lawrence, managing editor of the paper's *Examiner* rival, after Billy Smith, one of Thomas Sharkey's trainers, testified about the conspiracy to rob Robert Fitzsimmons of his prize fight win.

— PUBLISHED IN THE SAN FRANCISCO CALL, DECEMBER 10, 1896 —

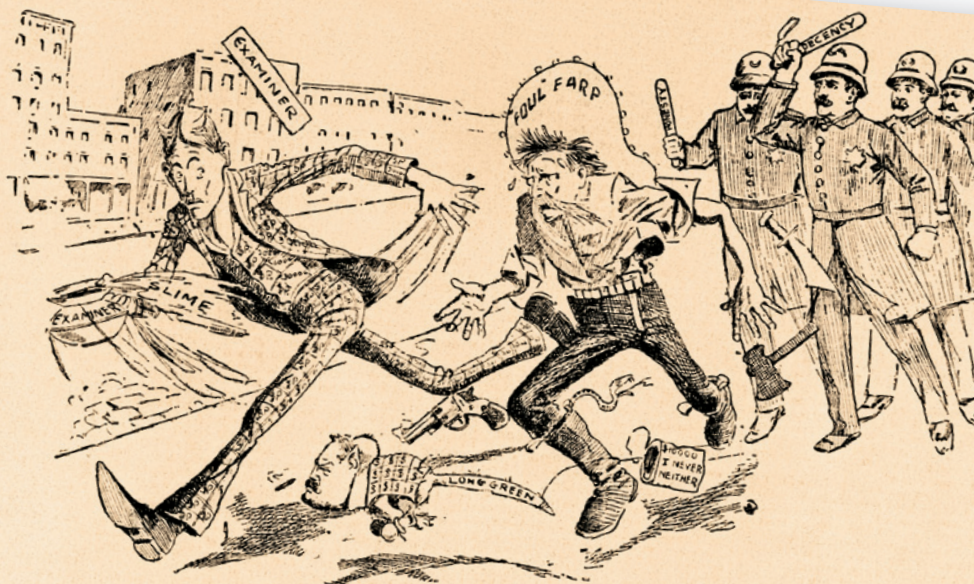

THE ENEMIES THEY HAVE MADE.

forced to disarm before the fight could proceed. Earp was later accused of fixing the fight when he called a foul against Fitzsimmons for a low punch and awarded the fight to Sharkey.

During the post-fight litigation, Earp denied all wrongdoing and repeated that he had called a square fight. Some believe the publicity Earp received from this notorious affair exceeded that of the Fremont Street gun battle in 1881, also known as the Gunfight Behind the O.K. Corral.

After the fight, Fitzsimmons and his manager, Martin Julian, filed a formal complaint against Sharkey, the National Athletic Club and others. Earp was not included. The complaint alleged that the fight was fixed. A restraining order was granted that blocked Sharkey from receiving the \$10,000 purse. After testimony from many involved in the fight, Superior Court Judge Austin A. Sanderson ruled the fight was technically illegal and therefore the court would not recognize the injunction.

THE REMARKABLE REFEREE

Earp felt betrayed by the sporting crowd and vowed to quit and return to a simpler life. His contemplation of this matter was short-lived; on March 16, 1897, he was seen in Carson City, Nevada, at the pre-fight festivities for yet another fight. While at the James "Gentleman Jim" Corbett versus Fitzsimmons fight, Earp accompanied Sharkey and manager Dan Lynch. *The Los Angeles Times* reported, "Earp looked as modest and unassuming as ever, with the same old suspicious bulge in his coat tails and the smile of self-satisfaction on his countenance."

In April 1897, the press announced that Earp had assumed the role of Sharkey's advisor and manager. Sharkey was desperately in need of a fight to prove

that he was qualified to fight reigning world champion James Corbett. The Sharkey camp contacted Peter "Irish Giant" Maher to arrange a match. Earp would not only assist Sharkey in preparation, but also would be his principal second in the ring.

Later that month, Earp and Sharkey headed east on the train to New York.

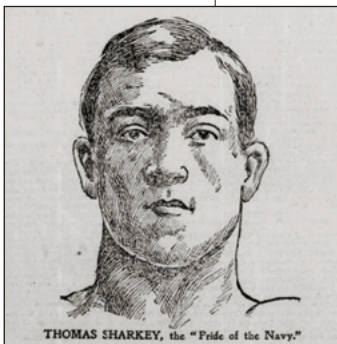
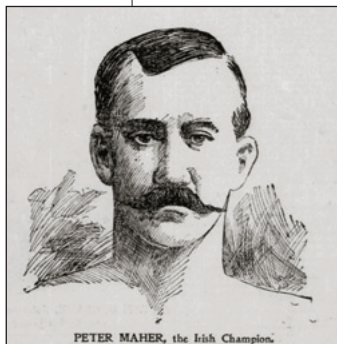

- PUBLISHED IN THE SAN FRANCISCO CALL, JUNE 10, 1897 -

Along the way, the men stopped in Yuma, Arizona, to visit with Earp's many Yuma friends. *The San Francisco Call*, while reporting Earp's whereabouts, sarcastically referred to him as a "remarkable referee and all around sport." Even *The Oasis* newspaper in Arizona took a shot at Earp when it proclaimed he was an "all-around tough citizen and Arizona is well rid of him."

The Sharkey-Maher fight was arranged to occur on June 9, 1897, at the Palace Athletic Club in New York City. The contest had serious consequences for Maher also. A win meant financial backing he could use to pursue a match with Fitzsimmons.

On the evening of June 9, a crowd of 7,500 people filled the Palace Athletic Club. A purse of \$12,000 was offered to the winner. A worldly cosmopolitan crowd showed up for the fight. Hundreds of Wall Street types, famous actors and others of the upper strata of society were in attendance. New York City's *The Sun* stated that the group "sat quietly and orderly as they would in their pews at church."

Unfortunately for fight fans, the event was to be run under the Horton Law, New

York's newly enacted ordinance, which expressly prohibited roughness or brutality. Contestants were only allowed to spar for points. Chief of Police Peter Conlin promised that at the first sign of brutality, the fight would be stopped and the men arrested.

Conlin's threat lacked credibility since the police enforced the Horton Law selectively. For example, in the Peter Maher versus Joe "California Terror" Choynski fight held the previous December, Maher brutally "put the Californian to sleep." The New York Police Commissioner watched the match from his front row seat and later remarked he had seen nothing brutal about the fight. The commissioner happened to be a then little-known man by the name of Theodore Roosevelt, the future 26th president of the United States and a boxing fan.

The night of June 9 began in a similar manner. During the first fight of the evening, Charlie Roden of Jersey City versus local boy Bobby Quaide, Roden knocked Quaide down twice with powerful punches to the jaw. By the second round, both men were staggering around the ring, much to the delight of the fans. After a particular harsh volley of punches to the jaw by Quaide, Referee Charley White stopped the fight in favor of Quaide. The police never got involved.

POLICE RUSHED THE RING

Sharkey and Maher entered the ring to the applause of the huge crowd. Both men were polite, smiling openly, and greeted each other in a friendly manner. The first rounds of the fight were likewise friendly. The men sparred like game chickens, throwing probing blows at each other. The crowd noted Sharkey was not aggressive as he had been during the Fitzsimmons fight.

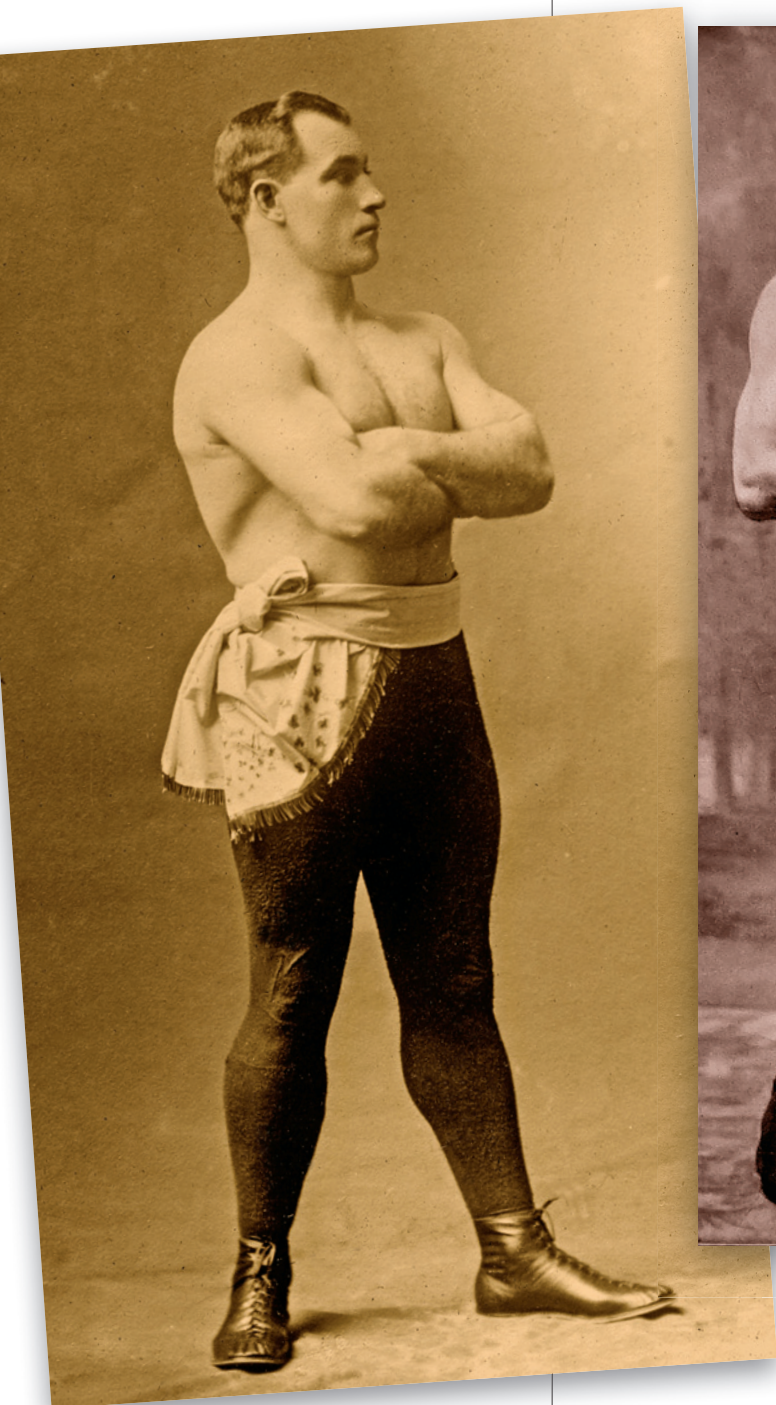

Wyatt Earp's friendship with Thomas Sharkey (above) suggests he may have indeed called a foul on Robert Fitzsimmons (above right) to give the win to Sharkey.

- TRUE WEST ARCHIVES -

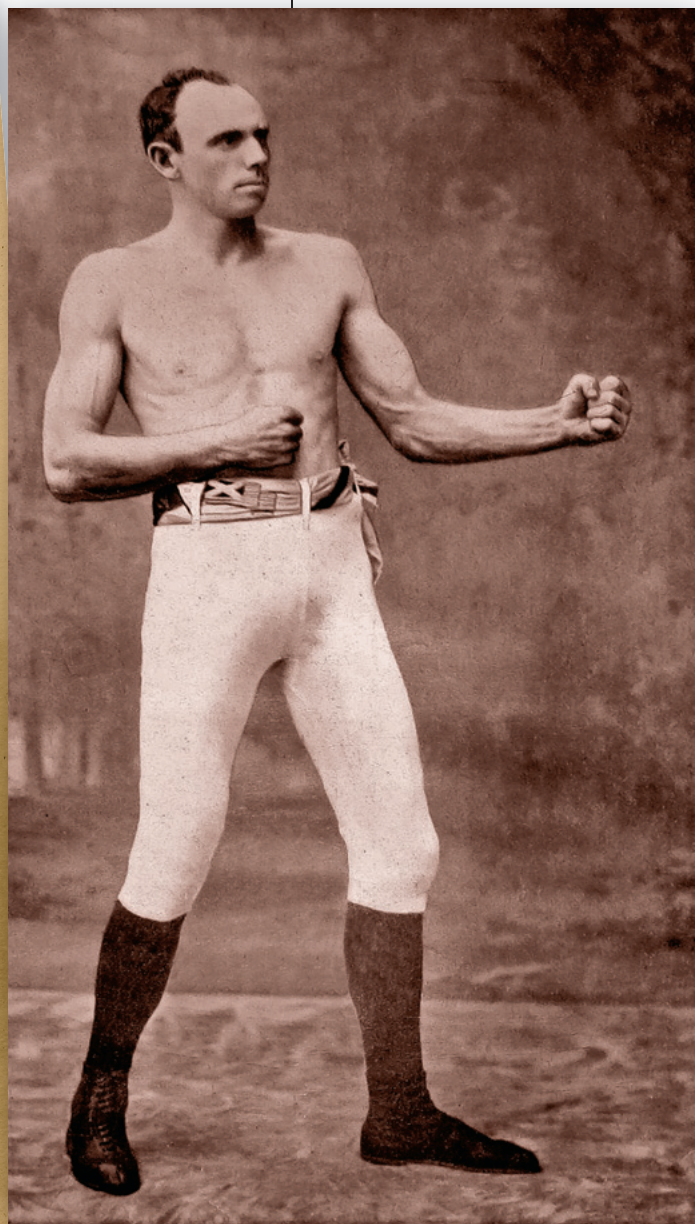

Fireworks started in the sixth round. Sharkey hit

Maher in the mouth, and as Maher was reeling, Sharkey nailed him hard on the neck with a right. Maher tumbled headlong and almost fell through the ropes. He was down five seconds, and when he got up, his lip was bleeding. Sharkey's corner man, Choynski, gave him advice, and Sharkey did not rush in. The crowd was in uproar, and the police edged toward the ring.

In the seventh round, Maher spoke to the "Sailor" in a low tone. What he said

could not be heard, and Sharkey did not respond. Maher then started forcing tactics for the first time. It was apparent Maher had been playing with Sharkey. Sharkey was now using both hands to slow the advancing Irishman.

Maher shot a terrific right-hander square on Sharkey's chin. Sharkey was near the ropes and left the floor, landing flush on his posterior with a jolt that shook the ring. He sat dazed for a moment and then drew himself up on the ropes. Maher was on him like a tiger, and they were fighting furiously when the bell rang. Neither man stopped at the bell.

The police rushed the ring and arrested everyone in the roped enclosure. The fighters and their seconds were furious when they realized what had happened. Authorities took the combatants to their dressing rooms.

Sharkey's seconds brought out Referee James Colville to render a decision. A draw was called. Announcer Charles Harvey conveyed the decision to the crowd. Everyone left in an ugly mood.

The principals, seconds, timekeepers and the referee were all arrested and locked up, but were bailed out an hour later. Steve Brodie posted the \$500 bail for Referee Colville, Sharkey and his manager, Lynch. This fueled the rumor circulated by *The San Francisco Call* that all, including Earp, were in cahoots together. The *Call* stated that everybody knew that if Sharkey should fail at any point to lead, and his chances of defeating Maher were unlikely, the police would interfere and stop the fight. The paper described the fight as a "very unsatisfactory contest."

The next morning, the fighters were arraigned before the Magistrate Robert Cornell. Cornell voiced his opinion that the fighters had acted disorderly, but within the law. When Mayor William Lafayette Strong was interviewed, he said he was against the Horton Law, because distinguishing between scientific sparring and prizefighting was hard to do, but that he believed the police had acted in good judgment.

FOOL ME TWICE, SHAME ON ME

The arbitrary enforcement of the Horton Law allowed the police to control any prizefight, for any reason they desired, including the improvement of their financial situation. Earp admitting the

"It was the most bald-faced steal that has ever been seen in the San Francisco prize ring and will do much to hurt boxing on this coast if, indeed, it does not kill it entirely," *The San Francisco Call* reported, on December 3, 1896, about Earp's "raw decision" that robbed Robert Fitzsimmons of his "well-earned victory."

— PUBLISHED IN THE SAN FRANCISCO CALL, DECEMBER, 3, 1896 —

FITZSIMMONS WAS ROBBED,
Knocked Out Tom Sharkey
but Lost on an Al-
leged Foul.
REFEREE EARP GAVE A
RAW DECISION.
The Cornishman Was Warned
Against Accepting the Ex Faro
Dealing Sharp.

fight was fixed pre-fight further confirms he knew of and could have been involved with the arrangement. His public airing of this fact indicates he learned from the Sharkey-Fitzsimmons fight and didn't want to be in the middle of that hornet's nest again.

How does this all relate to the Sharkey-Fitzsimmons fight? Likely possibilities of what happened during that fight include: the fight was fixed, and Earp was in on the affair; Fitzsimmons did foul Sharkey, and Earp made the correct call; or Sharkey pretended to have been hit below the belt and convinced Earp of the foul.

Little-known information regarding Earp's involvement was published by Charles Fernald in the 1951 edition of

the Chicago Posse of the Westerners *Brand Book*. In his article, "Wyatt Earp in Alaska," Fernald wrote of traveling on a ship to Alaska with Earp. Fernald claimed Earp told him that iodine had been injected into Sharkey's groin to simulate the injury. Furthermore, Earp added he didn't know about the iodine trick until sometime later. This statement

is consistent with an opinion rendered by Dr. David Lustig, who, post-fight, examined the injury. Lustig testified the swelling of the area was not indicative of the alleged cause of the injury.

The Los Angeles Times article published on June 4, 1897, is an important piece of information, which, in conjunction with Fernald's article and other details of the Sharkey-Fitzsimmons fight, certainly suggests the fight was fixed. Furthermore, Earp's newly developed friendship with Sharkey post-fight adds fuel to the theory that Earp was in on the fix. Why else would he befriend the central person in a scandal

that had caused him so much embarrassment and humiliation?

Earp never refereed another prizefight. In July 1897, he and paramour Josie returned to Yuma, Arizona, searching for the good life away from the public eye. A new chapter had begun in the life of the "Lion of Tombstone." ❖

Garner A. Palenske is a historian and author. Previously unpublished information regarding Wyatt Earp's time refereeing prizefights in San Diego and along the Mexican border can be found in his book, *Wyatt Earp in San Diego: Life After Tombstone*. Palenske thanks author Casey Tefertiller for his assistance locating the Chicago Posse of the Westerners *Brand Book*.

WYATT EARP

BY ALLEN BARRA

THE TRUTH ABOUT THREE ENDURING EARP LEGENDS.

Did Wyatt Arrest Ben Thompson?

This alleged arrest has driven researchers batty for decades. The most famous account appears in Stuart Lake's *Wyatt Earp: Frontier Marshal*.

Today, Ben Thompson's name is remembered only by a handful of Old West history buffs, but in his day, Ben was far better known on the frontier than Wyatt Earp. English born and Texas bred, Ben was sort of the Lou Gehrig or Jimmy Foxx of gunfighters in the 1870s, with James "Wild Bill" Hickok generally accorded the status of Babe Ruth. The two were champions of their respective regions: Ben having fought in the Confederate army, Hickok, in the Union. The two legends never faced each other, but since Lake was grooming Wyatt to eclipse Hickok, he gave Wyatt the confrontation with Ben that Hickok never had.

Lake's story has Wyatt, a complete unknown, riding into the thriving cattle station of Ellsworth, Kansas, in 1873, just after Ben's brother Billy killed the county sheriff, Chauncey "Cap" Whitney, in what was probably an accident stemming from Billy resisting arrest.

The 25-year-old, unarmed Wyatt, appalled that no arrests had been made, sarcastically remarked to the mayor, "Nice police force you have got." The mayor challenged Wyatt to take the job; Wyatt borrowed two gun belts and Colts, and walked down the main street to confront Ben.

"What do you want, Wyatt?" Ben asked.

"I want you, Ben," Wyatt replied.

"I'd rather talk than fight," Ben said.

"I'll get you either way," Wyatt said.

Curious thing about Ben's first question: he addressed Wyatt by his first name,

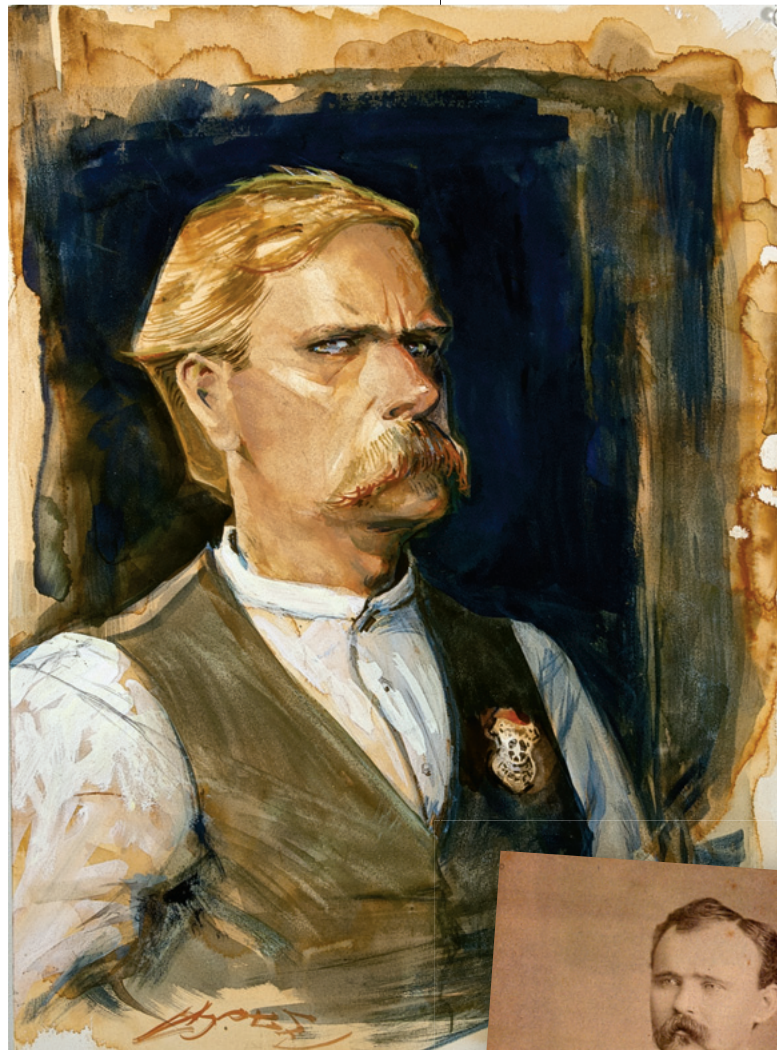

One of the biggest Wyatt Earp windies is the legend that the lawman (above) arrested gunfighter Ben Thompson (right) in 1863, in Ellsworth, Kansas.

— ALL ILLUSTRATIONS BY BOB BOZE BELL; BEN THOMPSON PHOTO COURTESY ROBERT G. MCCUBBIN COLLECTION —



MYTH BUSTERS

implying that he knew Wyatt from somewhere.

In any event, Ben shrugged and decided to take his chances in court, where, being a wealthy Texan and a cattleman, he would get preferential treatment. He was correct—the judge fined him \$25 for his role in shooting Whitney. The official charge was “disturbing the peace.”

Wyatt, the spiritual father of Dirty Harry, tossed his badge away in disgust and walked off. “Ellsworth,” he said, “figures sheriffs at \$25 a head. I don’t figure this town’s my size.”

Researchers have done everything but rip up the floorboards of Ellsworth’s sidewalks in their attempts to discover any truths in Lake’s story. I don’t know why they have persisted. Nothing has ever been found

to support it—not in court records, newspapers or eyewitness testimony.

One intriguing nugget does suggest an encounter between Ben and Wyatt that has gone curiously unheeded by researchers. It is published in John Flood Jr.’s manuscript, Wyatt’s first attempt at a ghost-written biography.

Ben was indeed arrested in Ellsworth after his brother killed Sheriff Whitney, not by Wyatt, but by local deputy Ed Hogue, who, ironically, would later be arrested by Wyatt for a misdemeanor in Dodge City. About a year later, Wyatt was in Wichita, where he got into a scrape with some Texans who, apparently, were friendly with Ben. The cause of the altercation is unknown, but, according to the manuscript, Wyatt told them, “Go back

uptown and ask Ben Thompson. He was in Abilene, he will tell you.”

Nothing more is known about the incident or whether or not the angry Texans did go uptown to confirm Wyatt’s story—whatever it was—with Ben. Presumably they did, and the problem, whatever it was, got resolved.

Wyatt’s words were not boastful. He didn’t seem to be suggesting he had arrested Ben in Ellsworth, Abilene or anywhere else. But Wyatt was using Ben as a sort of character reference, which implies some knowledge and at least a modicum of respect between the two men.

Back in Ellsworth, could Wyatt have intervened and perhaps even defused a potentially explosive situation by talking Ben into appearing before a judge and paying a small fine? Perhaps so. It wouldn’t have been the only time in Wyatt’s life that he had used a cool head to avoid trouble, which, after all, was the main job of a peace officer in a cowtown.

Did Wyatt Hold Back a Mob to Save Johnny-Behind-the-Deuce?

Yes, said Stuart Lake in his colorful 1931 Wyatt Earp biography.

No, say most modern historians.

On January 14, 1881, W.P. Schneider, an engineer living in Charleston, Arizona, stepped into a restaurant to warm his hands. Mike O’Rourke, an 18-year-old small-time gambler and troublemaker referred to as Johnny-Behind-the-Deuce—he apparently had a habit on betting on the deuce when playing faro—made some sarcastic comment to the effect of, “I thought you never get cold.” Schneider dismissed the teenager with a chilly, “I wasn’t talking to you.”

O’Rourke, swift to anger, threatened to kill Schneider. O’Rourke was seldom as good as his word, but this was one of the few times that he kept his promise. He ambushed Schneider and murdered him.



Ben Thompson was arrested in Ellsworth, Kansas, but the claim that Wyatt Earp deserves the credit is unsupported. Just four years after Thompson’s arrest, Alexander Gardner photographed the Kansas cowtown (see Main Street photos above).



No one knows what bad blood had passed between the two men that brought matters to such a conclusion, but the Deuce, who could properly be labeled as one of the tinhorn gambler element old-timers talked so much about, was immediately taken into custody. The local miners, among whom Schneider was popular, were outraged; calls to lynch the killer circulated.

Charleston's Constable George McKelvey was smart enough not to try and make a dash all the way to Tucson with his prisoner. He headed instead for Tombstone, but made about half the distance when a mob of miners closed in on his wagon.

McKelvey, and certainly O'Rourke, had the good fortune that Wyatt's brother Virgil was in the area, exercising Wyatt's horse, Dick Naylor. Virgil ordered O'Rourke to swing onto the horse's back and ride to Vogano's Saloon in Tombstone, where another Earp brother, James, was tending bar.

Before leaving Charleston, McKelvey had the presence of mind to telegraph Tombstone Marshal Ben Sippy to gather several armed men to prepare for the ride from Tombstone to Tucson. Yet the ugly mood had spread to Tombstone's miners. Before long, a throng of townspeople, several of them armed, advanced on the wagon Sippy was preparing for the journey.

Per Lake's account, "Five hundred blood-lusting frontiersmen"—John Ringo among them, by the way—poured into Allen Street as Virgil and Morgan, another Earp brother, got Johnny-Behind-the-Deuce to safety.

In *Frontier Marshal*, Wyatt stood close to the curb, shotgun in the crook of his

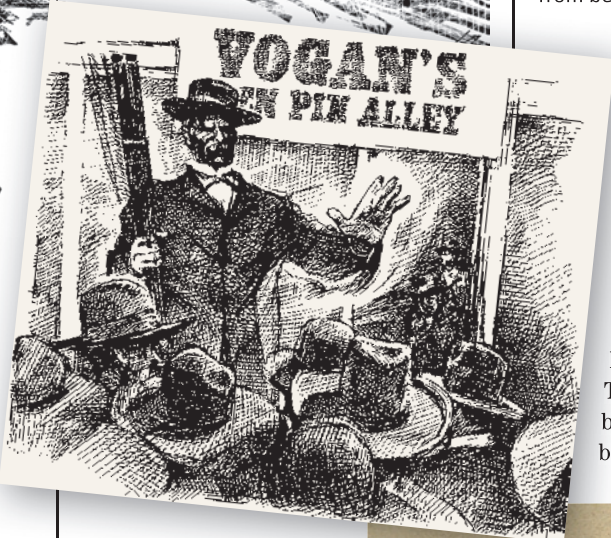

right arm, cautioning the front ranks of the mob: "Don't fool yourselves. That tinhorn's my prisoner, and I'm not bluffing."

Legend—or at least the legend created by Lake—states that the crowd dispersed.

Wyatt, though, wasn't the marshal or an officer of any kind and had no authority to call the Deuce "my prisoner." A modern debunker, Andrew Isenberg, in his 2013 book, *Wyatt Earp: A Vigilante Life*, points out the absurd histrionics used to highlight the incident in accounts by Wyatt researchers Forrestine Hooker, Flood Jr. and Lake, which, he says, "the authors all present as the most important episode in Wyatt's career as a Tombstone law officer prior to the [O.K. Corral] gunfight." Eisenberg also points out the similarity in the three accounts: "It's likely that Flood drew from Hooker and, later, Lake from both."

Much of the writing on the Deuce affair is pretty silly. Flood has it, "[Wyatt] was mighty, and he beheld them beneath his hypnotic gaze," and that Wyatt vowed to kill

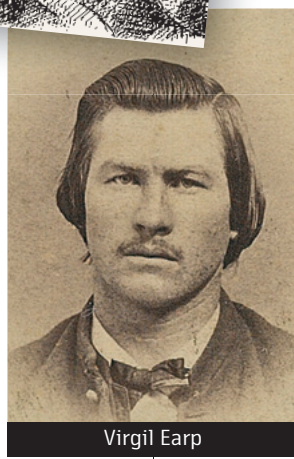

Virgil Earp

Tombstone Marshal Ben Sippy and Deputy Virgil Earp deposited their prisoner, Johnny-Behind-the-Deuce, at Jim Vogan and Jim Flynn's saloon and 10-pin bowling alley. By the time the Charleston mob joined in with enraged Tombstone citizens, Wyatt Earp was among the posse guarding the prisoner from being carried out for a lynching.

10 men if the mob rushed him.

To bolster the argument that Wyatt did not hold back a mob, Isenberg points to James Covington Hancock, who, in his memoir, claimed to be present when Johnny-Behind-the-Deuce arrived in Tombstone. "When Johnny was brought in, it naturally attracted a bunch of idly curious who gathered

around to see what was going on," Hancock stated. "Just a bunch of harmless 'rubber-necks'—I was one of them myself—no one armed and there was no demonstration of any kind. They put him in the buggy and drove off towards Benson as quietly as if they were going to a picnic."

Debunkers maintain Hooker, Flood and Lake got it wrong. They cite the January 27 issue of *The Tombstone Epitaph*, which

describes Ben Sippy as "cool as an iceberg, he held the crowd in check." Sippy, Cochise County Sheriff John Behan and Virgil Earp are singled out for praise. Wyatt isn't mentioned.

Isenberg concludes that the mob claim "was not the only time [Wyatt] appropriated the accomplishments of someone else as his own."

Wyatt also was not mentioned as being involved in the incident in the oft-quoted journal kept by Tombstone resident George Parsons. Walking along Allen Street that fateful night, Parsons came upon the mob, watched the proceedings and later recorded the event in his journal:



Mike O'Rourke (left) often bluffed with a deuce while playing faro, which is how he earned his nickname, Johnny-Behind-the-Deuce. When the miner killed a local engineer in Charleston in 1881, the Arizona camp looked much like the photograph taken by Tombstone photographer C.S. Fly, circa 1885.

- COURTESY ARIZONA HISTORICAL SOCIETY -

"The officers sought to protect [O'Rourke] and swore in deputies—themselves gambling men—to help. Many of the miners armed themselves and tried to get at the murderer. Several times, yes a number of times rushes were made and rifles leveled causing Mr. Stanley and me to get behind the most available shelter. Terrible excitement. But the officers got through finally and out of town with their man bound for Tucson."

Hancock's account is the easiest to dismiss. He never mentioned witnessing the incident until 50 years after the fact, and then his story doesn't square with anyone else's.

Why, though, didn't the *Epitaph* or Parsons' journal mention Wyatt? Probably because Wyatt wasn't an officer at the time. Parsons mentions no officer by name, but does say that deputies were sworn in—Wyatt and Virgil were among those deputies. The

Epitaph probably left out Wyatt's name for a simple reason: the newspaper was plugging its candidate for town marshal, Sippy.

Just because the Wyatt researchers' accounts were embellished, however, does not mean that the confrontation they described didn't happen. As we see over and over in the Wyatt story, something was alleged to have happened, was later debunked and then, after closer examination, was revealed to have happened after all.

What Isenberg neglects are the eyewitness accounts placing Wyatt at the forefront, namely by sometime-Wells Fargo agent Fred Dodge, *Epitaph* editor John Clum and Billy Breakenridge.

Dodge not only credited Wyatt with holding off the crowd, he also claimed Behan and Sippy stood off to the side and did nothing. Clum, in his later recollections,

gave Wyatt the lion's share of the credit and criticized Sippy, all but admitting that his newspaper had fudged the story when it first reported it.

Parsons also added in his two cents worth. In a 1903 article for the *Los Angeles Morning Review*, Parsons gave Wyatt almost full credit for stopping the mob. One cannot accuse Parsons of riding a legend—the first nationally distributed profile of Wyatt, Bat Masterson's story for *Human Life* magazine, was still four years away. One also cannot write his story as the hero worship of an old man—Parsons was not yet 50 when he wrote the story for the Los Angeles paper.

Why, then, didn't Parsons mention Wyatt in his journal in January 1881? The simplest answer is probably the correct one: he wasn't focused on Wyatt at the time.

For some strange and never explained reason, the strongest support for Wyatt's role in the Deuce standoff was Behan's own deputy, William Breakenridge. In his 1926 book, *Hell'dorado*, Breakenridge mentions Wyatt—and only Wyatt—at the incident. Wyatt, he wrote, "stood them off with a shotgun and dared him to come and get him. It didn't look good to the mob."

Here's the real oddity: Breakenridge didn't mention his boss, Sheriff Behan, at all.

Of all those who claimed to witness the clash of police and citizens that day, Breakenridge is surely the one least likely to present a pro-Earp account.

The later accounts of Wyatt's actions in saving Johnny-Behind-the-Deuce are definitely overblown and melodramatic. But when the hagiography is stripped away, some hard nuggets of truth remain: Wyatt was there, and O'Rourke never got lynched by that angry mob.

Historians have made much ado about nothing when it comes to painting Sexy Sadie as being in a love triangle with John Behan and Wyatt Earp in Tombstone, Arizona. Yet no contemporaneous records point to Josephine Marcus being Wyatt's girlfriend while they lived in the mining town.

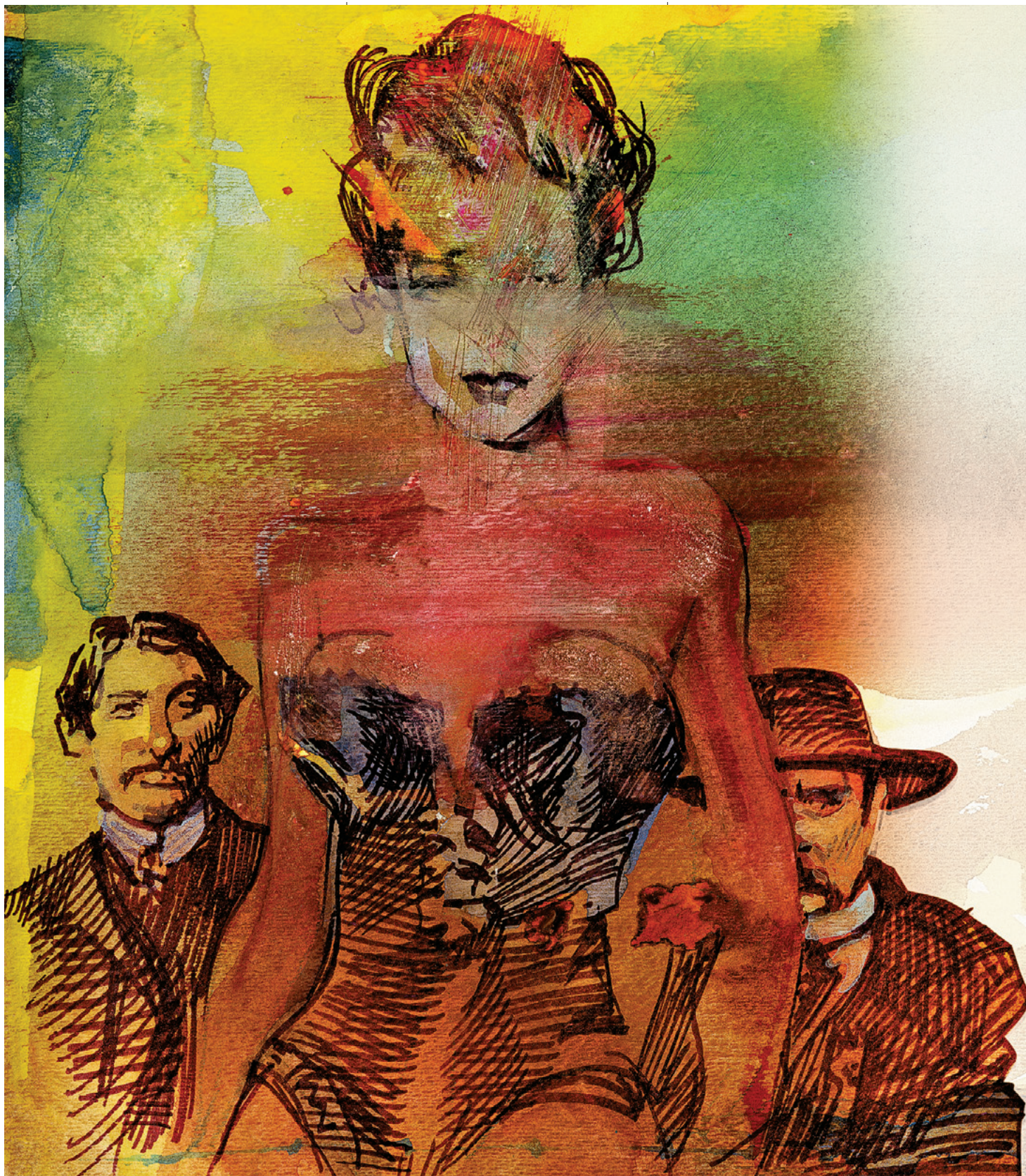



Allen Barra maintains that, despite the movies, no evidence proves Wyatt Earp and Josie had an affair during their years in Tombstone, Arizona. Josie stands under the mess tent of the pair's prospecting camp at the Colorado River crossing near Parker.

— COURTESY JEFF MOREY —

Were Wyatt and Sadie Marcus Lovers in Tombstone?

The emergence of Josephine Sarah Marcus in the Tombstone story was the real impetus for a revival of interest in the Wyatt Earp saga. In the space of a couple of decades, she went from someone given just a single mention in *Frontier Marshal* to Tombstone's "Helen of Troy," the supposed cause of hostility between Wyatt and Sheriff John Behan.

Stuart Lake, concluding his research in 1930, actually saw Josie—or Sadie, as her family called her—as the center of the story. "Johnny Behan," Lake wrote to his editor at Houghton Mifflin in 1929, "was a notorious 'chaser' and a free spender making lots of money. He persuaded the beautiful Sadie to leave the honky-tonk and set her up as his 'girl,' after which she was known as Sadie Behan." He added, "In the back of all the fighting, the killing, and even Wyatt's duty as a peace officer, the impelling force of his destiny was the nature of his acquisition and association in the case of John Behan's girl. That relationship is the key to the whole yarn of Tombstone. Should I or should I not leave that key unturned?"

Probably because Josie threatened to sue if Lake's story did not meet her approval, Lake decided against turning the key. She succeeded in keeping herself out of Wyatt's story—for a while, at least.

How much was there to the relationship that Lake defined as "the key to the whole yarn of Tombstone?" After Tombstone, the

couple moved together to California, and Wyatt was with Sadie for the rest of their lives. But what about their Tombstone story?

Historians, scriptwriters and novelists must have been surprised to find at the end of their research that nothing supports the notion of any kind of relationship between Wyatt and Josie while they lived in Tombstone, Arizona. Nothing—not a letter, not a newspaper item, not a single page of any memoir written by anyone who was in or around town during the Earp-Behan years—mentions Wyatt and Sadie being together.

The publication of Frank Waters' *The Earp Brothers of Tombstone* in 1960 brought out this idea, by implying that Wyatt was often seen on the town with the dazzlingly dressed Marcus on his arm. But we now know that the book's claims are fraudulent, and the discovery of Waters' original manuscript at the University of New Mexico, titled *Tombstone Travesty*—which differed from the published version—merely confirmed that, whatever knowledge they had of each other in Tombstone, Josie and Wyatt certainly weren't having an affair.

Tombstone was big for a frontier money camp, but it wasn't *that* big. Somebody—a family member, one of Wyatt's enemies or just plain gossipy people like Parsons—would surely have noticed.

Allen Barra is the author of *Inventing Wyatt Earp: His Life and Many Legends*. He writes about sports for *The Wall Street Journal* and is a contributing writer for *American History Magazine* and *The Daily Beast*. His last book, *Mickey and Willie: The Parallel Lives of Baseball's Parallel Lives*, was nominated for the Pen Award for Literary Sportswriting.



Wyatt Earp birthplace in happier days.

— BY GEORGE PEASE / WYATT EARP BIRTHPLACE —

Help! Wyatt Earp Birthplace Damaged

Famed gunfighter Wyatt Earp was born in an upstairs bedroom in the house at 406 E. 3rd Street in Monmouth, Illinois, on March 19, 1848. In 1986, Earp relatives sold the home to Bob and Melba Matson. In appreciation of the home's history, the couple restored the home, stocked a gift shop with books and memorabilia and sponsored summer Wyatt Earp celebrations at a makeshift O.K. Corral in an adjacent lot.

In the fall of 2014, the Matsons moved into assisted living near their daughter's home in Iowa. They rented the Wyatt Earp birthplace to alleged veteran Kelly Semande, who had impressed them with his knowledge of Earp.

In the spring of 2015, Semande fell behind on his rent. The Matsons checked in on the home and found a horror scene. Duct work had been ripped out. Plumbing and electrical destroyed. Sewer line damaged.

On May 31, 2016, Semande was sentenced to two years probation for a weapons charge as part of a plea agreement. The court determined the more than \$40,000 worth of damage was a civil matter.

The Matsons, both in their 80s, are determined to restore the Wyatt Earp Birthplace. Insurance will cover only \$9,000 of the repairs. The Board of Directors of the nonprofit Wyatt Earp Birthplace is asking for donations: GoFundMe.com/2pahz62s

The Wyatt Earp Birthplace is listed on the National Register of Historic Places as the Pike-Sheldon House. Any donations you can provide to help restore this piece of Old West history will be greatly appreciated.

BY ALLEN BARRA

Getting to Know Doc and Wyatt

Novelist Mary Doria Russell reveals her inspiration for writing about Doc Holliday, Wyatt Earp and the Gunfight Behind the O.K. Corral.

Allen Barra: *You have now written two superb, hefty novels involving Doc Holliday and Wyatt Earp. When did the idea first come to you to write fiction on this subject?*

Mary Doria Russell: Like so many, I love Kevin Jarre's screenplay for *Tombstone* and was completely charmed by Val Kilmer's portrayal of Doc Holliday, but I didn't get interested in the history behind the story until I accepted a position on my town's planning and zoning commission, helping to draft ordinances for gun shops and...well, tittie bars.

While studying gun control and vice zone laws that had passed Supreme Court challenges, I realized that my little town of South Euclid, Ohio, was dealing with exactly the same legal issues as Western boomtowns like Dodge City, Kansas, and Tombstone, Arizona.

I was struck by the parallels between our time and that of Wyatt and Doc. A recent war had divided the country. Vicious politics and a shamelessly partisan news media. Gang violence along the U.S.-Mexico border. Americans feeling threatened by the Chinese. There's even a sign being carried in the background of one scene in *Tombstone* about equal pay for equal work, regardless of sex! I'm consistently drawn to those I feel have been unfairly maligned. Writing about Doc Holliday fits that pattern.

I started reading biographies and decided that poor child deserved better than he got—from movies, from fiction, from history and from life. That led to the novel, *Doc*, which I thought would stand alone. I figured everybody knew all there was to know about the O.K. Corral. Obviously, I got over that. *Epitaph* is nearly 600 pages long!

Were there any other people you were drawn to?

Oh, for sure, the McLauray brothers! Their story completely changed my understanding of what happened on October 26, 1881. They were planning on leaving the next day for their sister's wedding in Iowa. Just knowing details like this led me toward the far more complex situation that I've tried to elucidate in *Epitaph*.

The true man behind the legendary Doc Holliday loomed large in the mind of author Mary Doria Russell, so much so that she followed the lonely dentist into his most famous gunfight.

— ILLUSTRATED BY BOB BOZE BELL
/ PHOTO MONTAGE BY DAN HARSHBERGER —



What fiction writers have had the biggest influence on you?

The Scottish historical novelist Dorothy Dunnett taught me to trust the reader's intelligence and patience. In her Lymond series, she let her main character be described by hostile witnesses, so to speak, and then when she finally let you see that character in private with his guard down, you felt privileged somehow to know him in a way that people in the book didn't. It's a neat trick and makes for a strong emotional connection.

I also admire Hilary Mantel's *Wolf Hall* and *Bring Up the Bodies*. She redefined Henry VIII, Thomas Cromwell, Anne Boleyn and Thomas Moore by unearthing the real people beneath a mountain of fiction and secondhand history. She works against centuries of presumptions and assumptions, and even though you're reading a novel, you think, "This is the real story. This is how it must have been."

And then there's Stacy Schiff's biography, *Cleopatra*. There's very little directly known about Doc Holliday, but even less about Cleopatra. Schiff shows how a careful biographer can put flesh on bones by understanding the world that surrounded a person and drawing inferences carefully from context.

A lot of fiction has been written about Tombstone and the street fight, some of it by good writers: W.R. Burnett's *Saint Johnson*, Loren D. Estleman's *Bloody Season*, Paul West's *O.K.* and *The Last Kind Words Saloon* by Larry McMurtry. Even the great Thomas Berger devoted a large chunk of *The Return of Little Big Man to Tombstone*. But no one has included so many characters from all phases of the story or fleshed them out the way you have.

Yeah, I always swing for the fences. But the other thing is, I wasn't writing about characters. I was writing about real people who took part in a real event. I wasn't just using their names. I wanted this account to be definitive and that

meant including all those who could shine an interesting light on what happened in Tombstone and why, and what the consequences were.

In *Epitaph*, you give the gunfight only 42 lines. Given all the moment-by-moment analyses of the shooting, why did you decide against a more detailed account?

I wanted the gunfight to feel as though it were happening in real time. No single participant or witness could see everything as it was taking place, and it was over before anybody realized the full horror of the event. Even in 1881, the post-hoc political spin, ass-covering and legal maneuvering came later, after everyone had time to think, consult with attorneys and plan their responses.

That's why I decided to see the gunfight itself through Tom McLaury's eyes. His perception is muddled by a concussion, and he's watching something unfathomable through a haze of powder smoke. He hardly knows where to look, and then suddenly, he realizes the danger, tries to react and boom! He's sitting on the ground with a four-inch hole in his chest.

Tom McLaury would never understand what happened during those fatal 30 seconds, or why. He was never going to have the benefit of hindsight because he was going to die in the next few moments. I wanted that immediacy. I wanted you to be in that last moment with Tommy, watching the snowflakes fall, hoping to go to heaven.

What made you give so much space to John Flood, with whom Wyatt worked on his first try at a biography?

Many of us in our 60s are now or recently have been caretakers for the even more elderly. We've been up close and personal with the sad realities of failing bodies and minds. Like John Flood, I wanted to see Wyatt and Josie through to the end.

When I started that part of the story, I knew Flood was a mining engineer who tried to help Wyatt write an account of

the gunfight, though the result was almost unreadable. I always try to find out about the childhood of any person I'm representing in my fiction and through Facebook, I've assembled a volunteer team of "genealogy genies" who track people down for me and follow up on what they find.

Census records told us that John Flood lost his parents and his only sibling when he was quite young. Knowing that he was an orphan helped me understand why he might be willing to help the Earps in their 60s and then remain responsible for them into old age. He wanted family. He wanted to be someone's son again.

Then one of the genies noticed that in all the census records from 1920 to 1950, John Flood shared a residence with Edgar Beaver. There is a Los Angeles real estate transfer in the 1930s when they bought a house together—and they're listed as "partners"—and their death records show that they died within months of one another in the mid-1950s.

Not only had we just broken new historical ground, but now I had a genuine love story that could leaven the sadness of the Earps' final years. John and Edgar were together just as long as Wyatt and Josie were! I was so happy for John that he had someone to stand with him and share the burden as Wyatt weakened and died, and as Josie descended into dementia.

Edgar was a journalist at one point, so his voice could be snarky and cynical, which is fun to work with and kept the final chapters from becoming maudlin. And since John and Edgar died in the mid-1950s, they might well have sat side by side on a sofa, eating popcorn and watching the premiere of *The Life and Legend of Wyatt Earp* on television.

That let me bring the story to a satisfying conclusion that was also living memory for a lot of Boomers. The end really is my favorite part of the book.



Author of acclaimed novels *Doc* (Random House, 2011) and *Epitaph* (Ecco/HarperCollins, 2015), **Mary Doria Russell** holds a Ph.D. in biological anthropology; she taught head and neck anatomy at the Case Western Reserve University School of Dental Medicine.

BY LEO W. BANKS

NEW DOC PHOTO DISCOVERY?

Look closely at the street scene from Silver City, New Mexico. Notice the skinny cat standing by the third stagecoach window, right hand in pocket, left hand on lapel. Could that man be John Henry “Doc” Holliday?

He does not appear to be throwing up blood, drunk, cranky or ready to draw down, but the man in the photo certainly resembles the revered gunfighter who participated in the 1881 Gunfight Behind the O.K. Corral in Tombstone, Arizona.

We know the Earp party, including our favorite tubercular dentist, spent the night in Silver City, New Mexico, on April 15, 1882, while fleeing Arizona after Wyatt Earp’s Vendetta Ride. A Wells Fargo historian confirmed that the man sitting atop the coach, holding an envelope, is the Wells Fargo agent in Silver City, G.M. Huffaker. Some historians believe that Wells Fargo was helping Earp evade the law.

The Silver City Museum, which owns this image, sent the photo to us to investigate. A notation in the museum’s collection stated the picture was taken “sometime between May 1881 and September 1882.”

We donned our Pinkerton hats and began poking around.

Old West photo collector Robert G. McCubbin took a look and dumped cold water on the Holliday possibility. Comparing it with the full-length shot of Holliday taken in Prescott, Arizona, he says the mustache doesn’t match and the chin is more pointed in the Prescott photo. He concludes the stagecoach group “could be anyone of that period,” adding that Holliday probably would not have allowed himself to be photographed while on the run.

Gary Roberts, Holliday’s biographer, says, “...while, for historical reasons, I would like this to be a photo of the vendetta posse, I have to conclude that there is insufficient evidence to confirm that it is.”

What about the purported date for this photo? The stagecoach rests in front of the Meredith-Ailman building. Was that bank around in mid-April 1882?

Yes, the bank was around, but the building looked different then. Susan

A MUSEUM IN SILVER CITY BELIEVES DOC HOLLIDAY CAN BE SEEN IN A LOCAL HISTORICAL PHOTOGRAPH.

Berry, retired director of the Silver City Museum, helpfully plowed through old newspapers and found evidence that she believes places the photo after April 1882.

The New Southwest reported that a street lamp was placed in front of a building two doors north of the Meredith-Ailman building in early July 1882. The far right side of the picture shows the street lamp, which wouldn’t have been there in April.

The same newspaper reported, on July 29, the installation of large gilt letters above the doorways on the new iron front of the Meredith-Ailman building. Those gilt letters are present in this photo.

The photo, Berry concludes, was taken no earlier than late July 1882. It probably was shot before November 14, when the bank re-opened, and it was taken before May 11, 1883, when the Higbee building (next door to the bank and hidden by a tree) got a second story.

Although this is a fantastic period photo, our skinny guy is not our famous gunfighter with his posse. Such results can break the hearts of the most stalwart of latter-day Pinkertons. But we won’t give up. Only two confirmed adult photos of Holliday exist and those are not enough for a man of such legend.

We want more and vow to keep looking. If you’re out there, Doc, hold fast. We’ll find you. ❏

Tucson-based **Leo W. Banks** drinks a toast to Doc Holliday whenever he visits the Palace Saloon in Prescott, Arizona.





HAVE WE FOUND ANOTHER PHOTO OF DOC?

The signed photograph of Doc Holliday (left), taken in Prescott, Arizona, in 1879, is one of four authenticated photographs of the famous dentist. The others show him when he was 20, graduating from dental school, when he was about one or two years old and the last when he was a baby in his mother's arms. Unfortunately, the below photo will not be added to the list. The man (see close-up, far left) is not our revered gunfighter.

- HOLLIDAY PHOTO COURTESY BILL KOCH COLLECTION; SILVER CITY PHOTO COURTESY SILVER CITY MUSEUM -



ATTN: PHOTO SLEUTHS

The stack of crates on top of the stagecoach are marked with skulls and crossbones. Our answer man, Marshall Trimble, says that was a warning symbol used for poison. Visit the *True West* Magazine Facebook page and tell us what you think these crates hold!

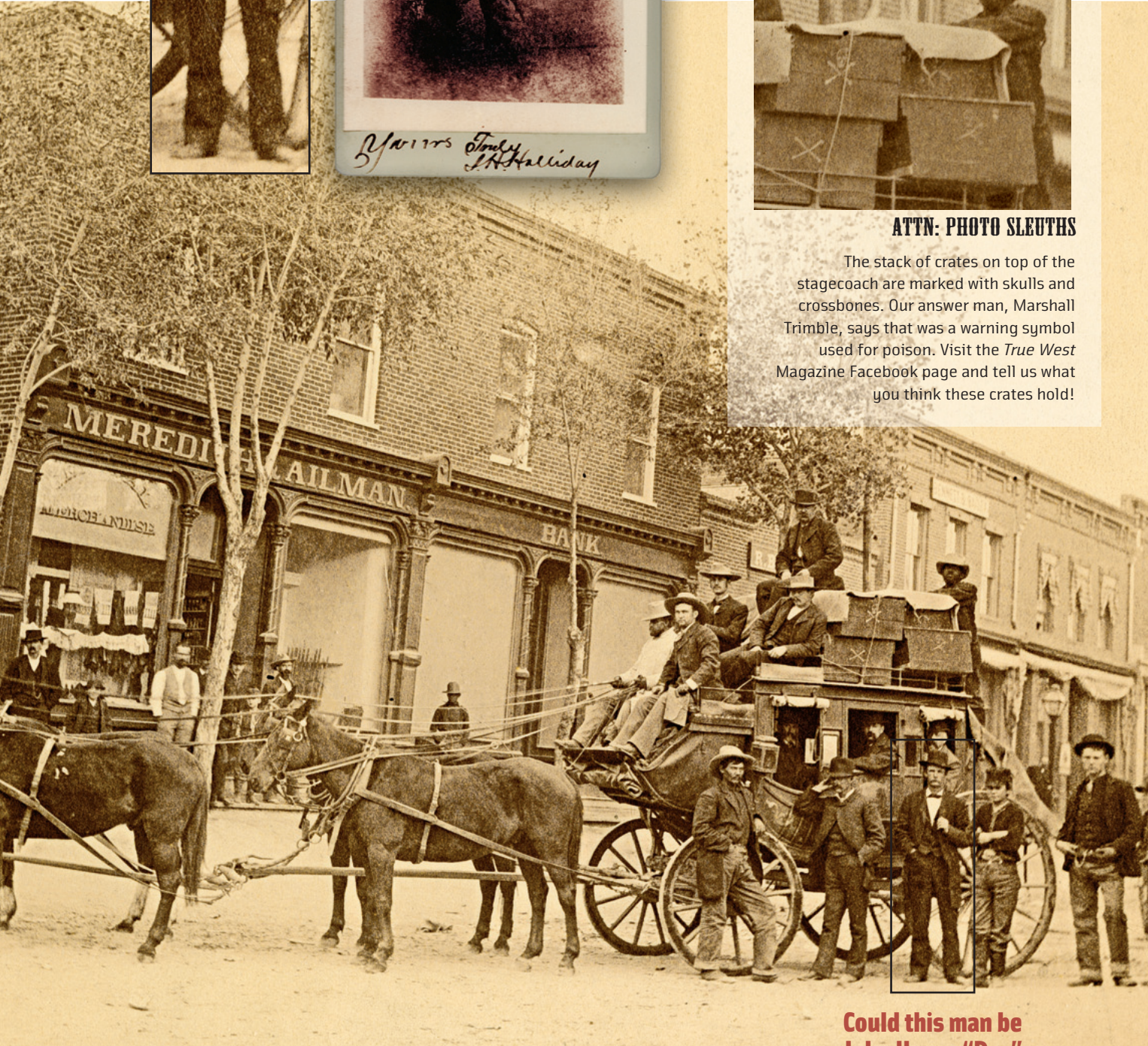

Could this man be John Henry "Doc" Holliday?

"I was standing at the Post Office with Mr. Dillen of the firm of Dillen and Kenealy...I walked down as far as Fly's [rooming house], and there I saw Sheriff Behan and four farmers. As I approached, one of them, Mr. William Clanton, put his hand on his pistol, as if in fear of somebody. When he recognized me he removed his hand."

—William Cuddy

"When I got to the corner of Fourth and Fremont Streets, I saw a large crowd of people on Fourth Street near the gunshop."

—P.H. Fellehy

"I told [Sheriff Behan] that we were just going to leave town and that I had no arms on. He then searched my waist."

—Ike Clanton

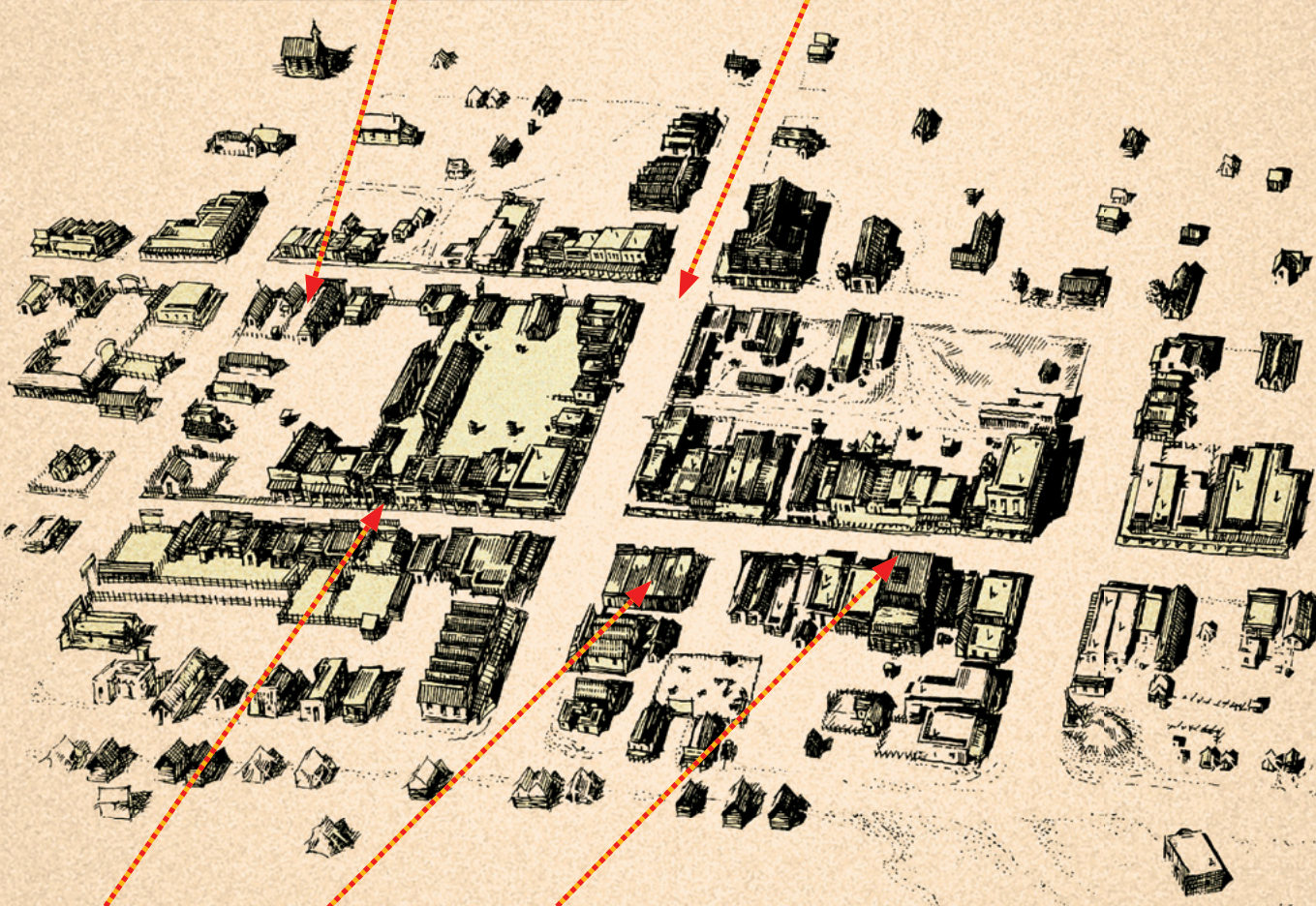

"I was standing at the front of the O.K. Corral on Allen Street. In Dunbar's Corral I saw the two Clantons [and] two McLaury boys in one of the stalls, in deep conversation."

—R.F. Coleman

"I slept late the day of the shooting. Got up about one or half-past one o'clock. I went to the barber shop to get shaved."

—John Behan

"I first saw Frank McLaury on that day pretty near the Grand Hotel as they were riding in. Frank McLaury, Bill Clanton, and an old gentleman who I am not acquainted with. This was about 2 o'clock in the afternoon. At first, Doc Holliday went out and shook hands with one of them in a pleasant way, and said, 'How are you?' or something of that kind."

—William Allen

"I was coming from my house to Bauer's meat market to get some meat for dinner. I saw quite a number of men standing in a group together on the sidewalk by the door of the market, and I passed on into the shop to get what I went for, and the parties in the shop were excited and did not seem to want to wait upon me."

—Martha J. King

"The day this happened, I went down with Ike Clanton to Dr. Gillingham's office to assist him in getting his head dressed, and then I walked up Fourth Street and met Billy Clanton and Frank McLaury, and Billy asked me where was Ike. He said, 'I want to get him to go out home.'"

—William F. Claiborne

October 26, 1881 Tombstone, Arizona Territory

— ALL MAPS AND INFOGRAPHICS BY GUS WALKER —

BY CASEY TEFERTILLER

THE WALK DOWN

**"I only want four feet of ground
to fight on!"**

—Ike Clanton, as quoted by Wyatt Earp



— ALL ILLUSTRATIONS BY BOB BOZE BELL —

It was the most famous stroll in American history. Neither fast nor slow.

Purposeful, with a sense of intimidation. It has been memorialized on film numerous times and repeated in the minds of nearly every visitor who has traipsed the streets of Tombstone.

The same will hold true today and tomorrow as new Westerners follow the footsteps of Dr. John Henry Holliday and the Earp brothers on the board planks that lead to the street outside the O.K. Corral.

The heart of the business district in Tombstone was on Allen Street, between Fourth and Fifth Streets. The Earps and Doc Holliday started their famous O.K. Corral walk down in front of Brown's Hotel. After Morgan Earp's assassination, in March 1882, the Earp families moved into the Cosmopolitan Hotel. All of these buildings were destroyed in the 1882 fire.

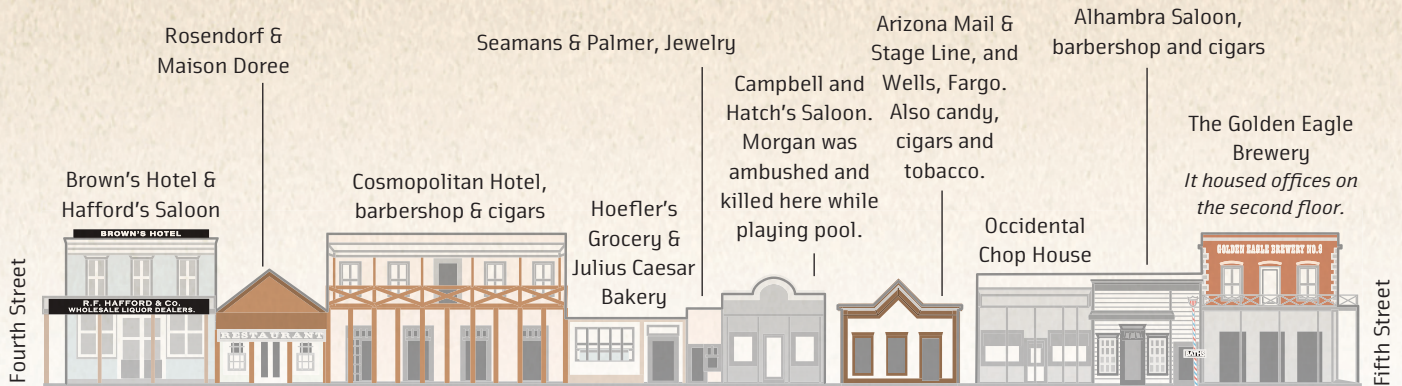

All-Night Poker Game

"I sat down in [the Occidental] saloon and played poker all night, until daylight.

Tom Corrigan was tending bar there in that saloon. Virgil Earp and Tom McLaury and another gentleman, I don't know his name, and Johnny Behan, were playing the game....When the poker game broke up in the morning at daylight, I saw Virgil take his six-shooter out of his lap and stick it in his pants. I got up and followed him out of doors on the sidewalk. He was going down Allen Street towards the Cosmopolitan Hotel. I walked up to him and told him in regard [to]...playing poker with a six-shooter in his lap, that I thought he stood in with those parties that tried to murder me the night before."



—Ike Clanton



"Wyatt Earp had on a short coat; did not have an overcoat on; [his pistol] seemed to me an old pistol, pretty large, 14 or 16 inches long, it seemed to me."

—A. Bauer, butcher

Pleased to Meet You, Hope to Kill You Soon!

Certainly one of the most bizarre turns in the byzantine events that led up to the gunfight was Doc Holliday's handshake with Billy Clanton in front of the Grand Hotel (see William Allen's quote, previous spread). Given the previous evening's fireworks with older brother Ike, Holliday must have been taunting the younger Clanton with ironic humor.



Night Before the Nightmare

As Ike Clanton seethed, Wyatt Earp slept. And so did his brother Virgil and Dr. John Henry Holliday.

They had all stayed up quite late; Virgil playing poker, and Wyatt overseeing the growing rage between Ike and Holliday. The Earps thought they had mollified the situation by the time they crawled under the sheets in their respective homes near the corner of First and Fremont.

Ike walked the streets of Tombstone on that fateful morning of October 26, 1881, telling just about anyone who would listen that he planned to cause trouble. “He said that as soon as the Earps and Doc Holliday showed themselves on the street, the ball would open, and they would have to fight,” bartender Ned Boyle said.

Boyle then raced to Wyatt’s house to awaken his friend and report Ike’s threats. Wyatt heard him out. Then he went back to sleep. Deputy Marshal Andy Bronk heard the talk around town, and he went to wake Virgil. Virgil listened, and he went back to sleep. Ike’s mouth was not worth losing sleep.

Ike went near the boarding house where Holliday and his love interest, Kate Elder, lay sleeping. Clanton again made threats, and proprietor Mary Fly banged on the door. Kate answered to hear Fly say, “Ike Clanton was here looking for [Holliday], and he had a rifle with him.”

Kate awoke Doc, who told Kate, “If God will let me live to get my clothes on, he will see me.”

The Earp brothers had not taken Ike seriously enough to get out of bed, but the intensity of the situation continued to grow as that cold morning progressed toward noon. When they finally left their beds, they would not sleep easily again for a long, long time.

“I got up the next day, October 26, about noon.”

—Wyatt Earp

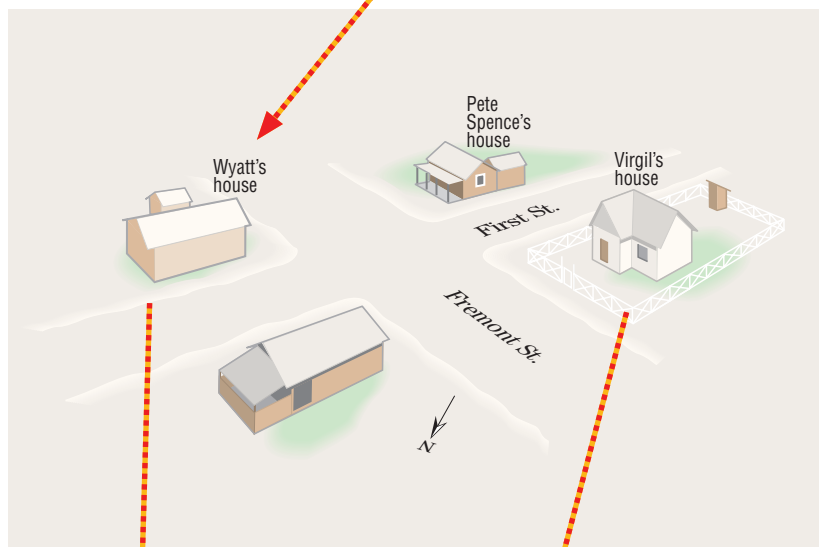

Tombstone, 1881

— ALL IMAGES TRUE WEST ARCHIVES
UNLESS OTHERWISE NOTED —





"I saw the marshal in the doorway of a vacant store with a double-barreled shotgun. He had the shotgun in his left hand."

—P.H. Fellehy

"I saw Holliday put [a six-shooter] in his coat pocket. I saw one in Morgan Earp's pocket, on the right side of his coat. Wyatt had his right back here, (indicating) stuck in his pants. I think a little on the right side...I was about 10 or 12 feet from Holliday, Morg and Virg."

—Wesley Fuller, testifying at the Spicer Hearing

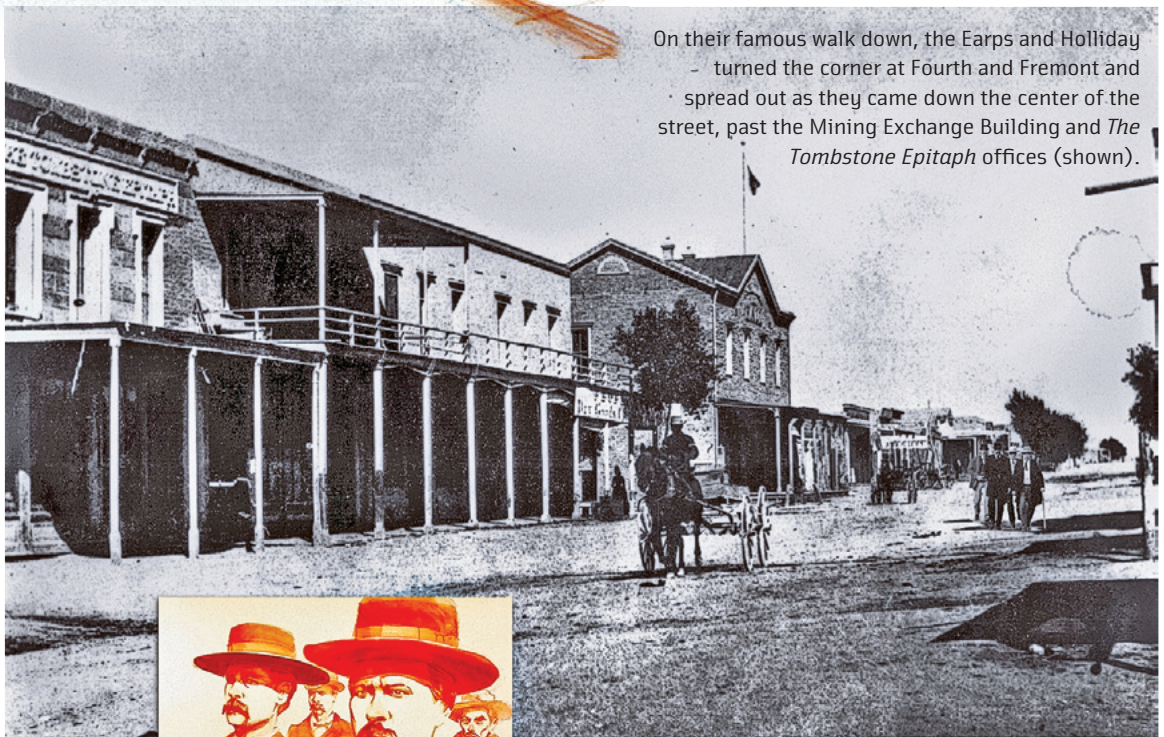

On their famous walk down, the Earps and Holliday - turned the corner at Fourth and Fremont and spread out as they came down the center of the street, past the Mining Exchange Building and *The Tombstone Epitaph* offices (shown).



"I saw four or five men standing in front of the O.K. Corral [on Allen Street]...talking of some trouble they had with Virgil Earp, and they made threats at the time, that on meeting him they would kill him on sight. Some one of the party spoke up at the time and said they would kill the whole party of Earps when they met them."

—H.F. Sills

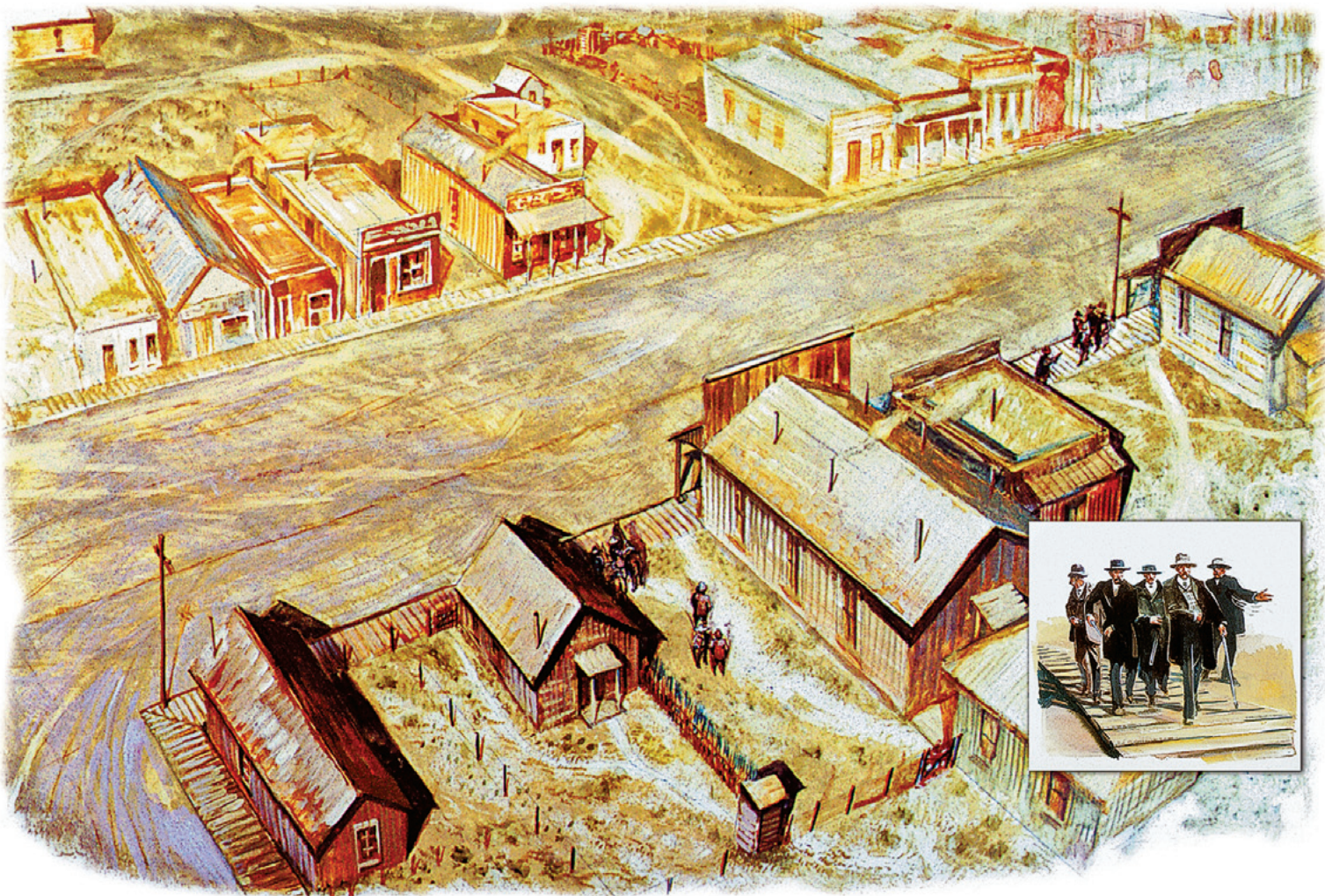

“The day the shooting commenced, I was standing there with Ike Clanton and Billy Clanton, Tom and Frank McLaury, and Johnny Behan. We were standing between the photograph gallery and the little house next to it.”

—*William Claiborne*



“To all appearances, Tom McLaury was not armed at the time he was at the shop—there was nothing in sight to show he was armed. He had on a dark blue blouse of light material and dark pants and vest. The blouse came down about the length of his arms. It was outside of his pants.”

—*James Kehoe, a butcher at Bauer's meat market*

A Most Damning Witness

At face value, Martha J. King provided perhaps the most cruelly damning testimony presented against the Earps. It was succinct and powerful.

A housewife stopping at the Union Meat Market, she had heard the rumors of impending trouble. She dashed to the front of the store, near the folding front door, as the Earp party passed, just in time to hear someone utter the words:

“Let them have it.”

She heard Dr. John Henry Holliday respond, “All right.”

Mrs. King then darted toward the back of the meat market and heard gunshots ring out.

The only member of the Earp party she recognized was Holliday. She had shared a stagecoach ride with his paramour, Kate Harony, a few weeks earlier, so we can suppose she was aware of Kate’s love interest.

Her testimony at the Spicer Hearing portrayed one of the Earp party instructing Holliday to blast away the cowboys. More than a century later, her statement is still chilling to read, as it seems to indicate prior intent for murder.

But what did the words she heard mean? The statement seemed to indicate an immediate barrage of bullets would have occurred. Yet the Earp party did not reach the vacant lot, a few steps away, and “Let them have it.” Rather, Marshal Virgil Earp demanded the cowboys surrender their weapons and exchanged words with them before exchanging gunfire. So the words from an unidentified Earp certainly could not have been instructions for a slaughter.

More likely, she had heard a snippet of a conversation. Perhaps, “If Behan

wants the shotgun, let ’em have it,” or some such other innocuous comment. It could even have been something to the effect of, “If they draw their pistols, let ’em have it.” Even that would not have shown prior intent for murder, as indicated by King’s testimony.

Yet the woman heard what she heard, and her testimony has incited a debate that has lasted throughout history.



Martha Jane King
- COURTESY JACK AND CAROLYN
ENDECOTT LITTLE -



Believed to be a C.S. Fly photograph of the empty lot (behind the burro) where the fight took place.

— COURTESY STEVE ELLIOTT / TOMBSTONE WESTERN HERITAGE MUSEUM —

“I saw this man [Camillus S.] Fly come out of his house with a Henry [rifle] in his hand. He made a remark, pointing to Billy Clanton below, who was lying on his back with a pistol in his right hand. Fly said, ‘Take that pistol away from that man!’” referring to Billy Clanton, I suppose. Clanton seemed to be in the act of trying to cock it, but did not seem to have strength enough to do so, as near as I could judge. I said to Mr. Fly, ‘Go and get it yourself if you want it.’”

—Robert S. Hatch

“We could not see them. All we could [see] was about half a horse. They were all standing in a row, Billy Clanton and Frank McLaury had their hands on their six-shooters. I don’t hardly know how Ike Clanton was standing, but I think he had his hands in an attitude where I supposed he had a gun. Tom McLaury had his hand on a Winchester rifle on a horse.”

—Virgil Earp



The Moment of Truth—A Misdemeanor Arrest Gone Awry

When the Earps and Holliday entered the narrow space between C.S. Fly’s gallery and the Harwood house, they confronted quite a crowd. In addition to Ike and Billy Clanton, Tom and Frank McLaury, the participants included Billy Claiborne (who was fading fast), Johnny Behan and Wes Fuller, who had come to warn Billy Clanton of the Earp’s bloody intent. Unfortunately for Claiborne, Fuller got sidetracked from his mission by Mattie Webb, a saloon owner and prostitute.

✘ Casey Tefertiller is the author of *Wyatt Earp: The Life Behind the Legend*. He is working on the forthcoming book, *The Last Deputy*.

TRUE WEST
EXCLUSIVE

CLASSIC GUNFIGHTS

O.K. FIGHT

THE EARPS & DOC HOLLIDAY VS THE CLANTONS & MCLAURYS

“THREE MEN HURLED INTO
ETERNITY IN THE DURATION
OF A MOMENT”



One man survives the fight without a scratch.

— ILLUSTRATIONS BY BOB BOZE BELL —

BY BOB BOZE BELL

Based on the research of Robert Palmquist, Carl Chafin, Jeff Morey, Allen Barra, Casey Tefertiller and Jim Dunham

OCTOBER 26, 1881

The Earp brothers and John Henry “Doc” Holliday confront the Cowboys in the vacant lot between C.S. Fly’s Boarding House and the house of former Mayor William Harwood, west of the rear entrance of the O.K. Corral, in Tombstone, Arizona Territory. It is a narrow, 18-foot space, which is somewhat ironic considering Ike Clanton’s earlier boast: “All I want is four feet of ground.”

“Boys, throw up your hands,” Marshal Virgil Earp demands. “I want your guns.”

Nervous about the confrontation and sensing the bristling attitude of Morgan Earp and Holliday, Frank McLaury says, “We will,” and makes a motion to pull

out his revolver. Holliday makes a sudden move toward Tom McLaury, thrusting the shotgun at him in a threatening manner. Wyatt Earp jerks his pistol from his coat pocket, and Billy Clanton pulls his revolver at the same time.

“Hold on, I don’t want this!” says Virgil, realizing the situation is slipping from his control.

Two shots ring out, almost as one, followed by a long pause. Frank McLaury clutches his stomach and staggers, as the firing becomes general (Ike Clanton flees once the shooting starts).

Some 30 shots are fired in less than 30 seconds. The most famous and over-analyzed fight in the West is over. The repercussions are only beginning. ★



After the first two shots are fired, followed by a long pause, the fighting becomes general. Ike Clanton runs up to Wyatt Earp and wrestles with him before fleeing. Wyatt later claims in the Spicer Hearing that he told Ike, “This fight has commenced. Get to fighting, or get away.”

Doc Holliday shoots Tom McLaury with the Wells Fargo shotgun. Virgil Earp is hit in the calf of his leg and goes down, while Morgan Earp is hit across the back.



In the final phase of the fight, Morgan Earp and Doc Holliday confront Frank McLaury out in the middle of Fremont Street. With his pistol across his left arm, Frank aims at Holliday and says, "I've got you now." Holliday turns sideways toward Frank, aims back and says, "You're a daisy if you do." Morgan Earp, who has tripped on a mound of dirt for the new waterline, rises to a sitting position and fires at Frank. The ball takes effect below the right ear, killing him instantly.

How Old Are the Gunfighters?



Virgil Earp, 38



Ike Clanton, 34

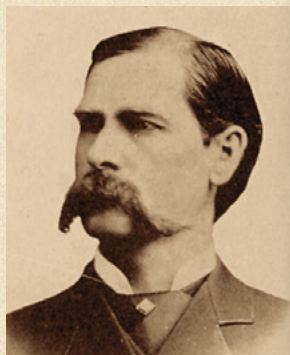

Wyatt Earp, 33



Frank McLaury, 32



Morgan Earp, 30



Doc Holliday, 30



Tom McLaury, 28

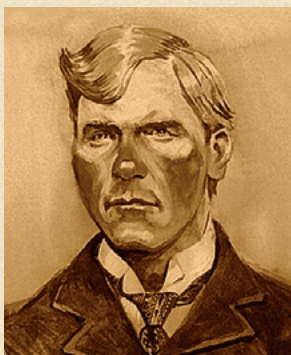

Billy Clanton, 19

No photographs of Billy Clanton alive are known to exist, but the artistic representation shown here portrays how we think he may have looked: brash, full of confidence and a bit of a hothead.

Aftermath: Odds & Ends

Some believed Frank McLaury did all the damage. His shots hit Morgan Earp across the shoulders, Virgil Earp in the right calf, John Henry "Doc" Holliday on the hip and punctured Wyatt Earp's coat, missing him by an inch. Had Frank not been gut shot in the first exchange, he might have killed them all.

Camillus S. Fly ran out from his boarding house and took the pistol from Billy Clanton's hand. As he gasped for air, the dying Clanton gamely asked for more cartridges.

The Vizina Mine whistle blew, signaling the Vigilance Committee to assemble for an emergency. Within minutes, they were mobilized by twos on Fremont Street. As 70 armed men converged on the scene, the Earps and Holliday anxiously realized they were out of bullets and wondered if the approaching throng was friend or foe.

Cochise County Sheriff John Behan stepped out from hiding and tried to arrest Wyatt, who replied, "I won't be arrested now. You threw us, Johnny."

The wounded Earps were taken to a "drugstore" uptown where their wounds were treated. Virgil and Morgan were loaded in a hack and pulled by hand to their homes at First and Fremont Streets. The lifeless bodies of Billy Clanton and Tom and Frank McLaury were taken to the Dexter Corral and placed in a back room to await the undertaker.

Billy Clanton lingered for half an hour, thrashing around and yelling. "They have murdered me!" he screamed.

Ike Clanton filed murder charges against the Earps and Holliday with Justice Wells Spicer.

Recommended: *The Illustrated Life and Times of Doc Holliday*, *The Illustrated Life & Times of Wyatt Earp* and *Classic Gunfights, Volume Two: Blaze Away! The 25 Gunfights Behind the O.K. Corral* by Bob Boze Bell, published by Tri Star-Boze Publications

When Johnny Behan changed his story, he transformed the historical view of the Gunfight Behind the O.K. Corral.

Behan's Lies

BY CASEY TEFERTILLER

One humiliation followed another for popular sheriff Johnny Behan on that fateful October afternoon. He stepped into the middle of a tense situation to prevent a gunfight, only to see the bullets fly around him and three of his friendly constituents shot to death. Then Wyatt Earp nervily sassed Behan in the middle of the street, right in front of several citizens who would certainly spread the story throughout the town.

As the dead bodies were gathered from Fremont Street in Tombstone, Arizona Territory, Behan had a problem: How could he frame the events of the day to make himself look good? What would he tell the press? How would he face the lawmen Earp brothers when the tension had cooled? How could he spin humiliation into heroism?

While the sun set on Tombstone, he came up with one account. Then he changed his mind. And, in doing so, he forever transformed how future generations viewed the “street fight” known today as the Gunfight Behind the O.K. Corral.

Man About Town

Behan had that gift of likability, a great attribute for a politician. He could tell a joke or a good story, entertain a crowd and make friends wherever he went.

In Territorial Arizona, he became popular not just with the merchants and miners, but also with the crowd referred to as “cow-boys,” marginal ranch workers who often engaged in sordid activities. This group included the Clanton and McLaury families, who owned ranches that reportedly bought and sold cattle acquired from rustlers. Behan got along with everyone. Almost everyone.

The well-liked sheriff slept late on that blustery day of October 26, 1881, awakening to find his town in turmoil. He tried to stop a tragedy by confronting Frank McLaury and ordering him to give up his guns. Frank refused and, minutes later, he lay dying with his brother Tom and Billy Clanton. After the shoot-out, Behan tried to arrest Wyatt, only to have the lawman publicly refuse.

In the aftermath of the gunfight, Behan attended three important meetings: He talked with *Tombstone Nugget* City Editor Richard Rule, he visited Wyatt's wounded brother Virgil at his bedside and, in all likelihood, he spoke to Ike Clanton, who had turned himself in at the jail for his own

protection. During the course of the evening, Behan changed his mind.

When the shooting ended, Rule scurried around town to learn the details. The *Nugget* was a Democratic, pro-Behan newspaper. On that fateful day, Harry Woods, both publisher and undersheriff to Behan, was collecting prisoners in El Paso, Texas. For Rule not to talk to Behan for his article would have been unthinkable.

Rule wrote his *Nugget* piece in a style of the day, telling the story, rather than using direct quotations, a method that left out attribution or sources. Rule did not identify Behan as a source, but the information could only have come from the sheriff.

“During the shooting Sheriff Behan was standing nearby commanding the contestants to cease firing but was powerless to prevent it,” the *Nugget* reported.

The battle began when Frank made a motion for his pistol, the newspaper stated, adding that Wyatt responded by drawing his pistol and firing, while Doc Holliday let loose with his short-barreled shotgun. Rule's report that Frank had gone for his guns justified the actions of the Earp brothers and Holliday.

Rule probably would not have written up this version of events had Behan told him a dramatically different story that implicated the Earps in some wrongdoing.

When Behan visited Virgil's bedside, Virgil recounted the fight to him, saying that one of the McLaury boys had drawn their gun to initiate the action. Behan told him, “I am your friend, and you did perfectly right.”

Then Behan made his way to the jail for a meeting that would shape history. Historians can never know with certainty what occurred when Behan sat down with Ike that night. Earlier in the evening, Behan had told both the *Nugget* and Virgil that the Earps were right in their actions. But something would change after Behan's discussion with Ike.

Behan's Surprising Testimony

Two days later, Behan told a different story at the coroner's inquest. He testified that the first shot had come from a nickel-plated pistol held by one of the Earp crowd. He was watching the Earps, not the cow-boys, so he could not testify about whether one of them had also made a motion for a gun.

In the weeks that followed, Behan became a key witness in the preliminary hearing known to history as the “Spicer Hearing,” in which Judge Wells Spicer presided over extended testimony to

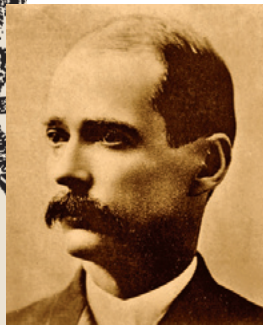

John Behan became the first sheriff of the newly designated Cochise County in 1881. A political adversary to lawman Wyatt Earp, Behan tried to change the course of history in

his testimony about the Gunfight Behind the O.K. Corral. When his plan failed, he was further emasculated when he learned that after his paramour Josie broke up with him, she began a romance with Wyatt that would last for the rest of her years.

— O.K. CORRAL GUNFIGHT ILLUSTRATION BY BOB BOZE BELL; BEHAN PHOTO TRUE WEST ARCHIVES —

determine whether enough evidence existed to bound over the Earps and Holliday for a jury trial. Ike had filed the murder charge against the Earp contingent. History does not record why Ike, instead of the Territory of Arizona, filed the charge, but the most likely reason was so Ike could hand-pick his attorneys to prosecute the case, instead of leaving it in the hands of District Attorney Lyttleton Price. Ike amassed a dream team of prosecutors, led by brothers Ben and Briggs Goodrich. The Earps countered with excellent attorneys of their own, led by Thomas Fitch.

As the hearing ensued, Ike, Billy Claiborne, local merchant Billy Allen and 19-year-old Wesley Fuller all testified that they had seen the Clantons and McLaurys surrendering when the Earps and Holliday fired upon them.

Under oath, Behan testified that he had his eyes on the Earp party as they fired the first shots of the gunfight.

But Behan had a motive to lie.

Wyatt was angling to run for sheriff in the November 1882 election. The two had not been friendly for months, after Behan reneged on his promise to make Wyatt his undersheriff for the newly formed Cochise County. By late 1881, Wyatt may have been keeping time with Josephine Marcus, Behan's former live-in lover who had left the sheriff when his affections strayed, although no evidence has been found to support this claim. At the very least, Behan had political reasons to want Wyatt out of the way.

Fitch Sets His Trap

Behan's testimony during the Spicer Hearing resembled a delicate tightrope walk, where he avoided directly contradicting what he told Rule for the *Nugget* article. He was watching the Earps, so he could not have seen the actions of the Clantons and McLaurys. If the ranchers made a motion for their pistols, he would not have known.

During cross-examination, Behan's responses became particularly interesting. One enticing question was, "If anything, how much have you contributed, or have promised to contribute, to the attorneys who are now prosecuting the case now associated with the district attorney?"

"I have neither contributed nor promised to contribute one cent," Behan answered.

Yet more than a century later, an important detail has become public. Behan did make a contribution of sorts. He served as

guarantor on a loan to Ike during the hearing, an action that would be as dubious then as it is now.

Fitch asked Behan what had transpired during his visit with Virgil on the night of the gunfight. The sheriff stoutly denied that he had ever said he saw one of the McLaurys draw his pistol to begin the fight, or that he had uttered the words, "I am your friend, and you did perfectly right."

Fitch stopped his cross on the subject. He had the testimony he needed. Fitch had set his trap.

Weeks later, on November 28, Fitch called Winfield Scott Williams to the stand. Williams had recently been appointed an assistant district attorney by Price. He likely would have to work with Behan on future cases, which made his testimony shocking.

When Behan came to call in on Virgil, Williams had also stopped by for a visit. He testified that he was there when Behan arrived. He then confirmed Virgil's version of the meeting, saying that he had heard Behan say one of the McLaurys initiated the action, as well as tell Virgil, "I am your friend, and you did perfectly right."

Williams took the stand to essentially call Behan a liar. This was a pivotal moment in the case and a critical element to understanding what actually occurred that day in Tombstone.

Justice Prevails

A few days later, Justice Spicer would determine that there was not enough evidence to show a likelihood of conviction, and the Earps and Holliday were not bound over for trial. The long, agonizing hearing ended, and the Earps returned to the streets of Tombstone.

Behan had every motivation to lie when he took the witness stand. He had the chance to eliminate his rival and improve his political position. An intense examination of the evidence makes it appear that lying is exactly what Behan did. He told one story to Rule and Virgil before he met with Ike, when they cooked up a much different, darker story that could carry the Earps to conviction, perhaps even to the noose. And he left behind a puzzle for historians to ponder and debate for more than a century.

Casey Tefertiller is the author of *Wyatt Earp: The Life Behind the Legend*. He is working on the forthcoming book, *The Last Deputy*.



BY ALLEN BARRA

THE REEL WALK DOWNS

The walk that never ends.

The walk down to the lot behind the O.K. Corral has become a ritual in Tombstone productions—re-created, imitated and parodied in perhaps two dozen movies and TV shows, the first step of which, like the crossing of the Rubicon, changes history and becomes mythology. Here are eight of our favorites.



***The Wild Bunch* (1969)**

They aren't headed toward the O.K. Corral; they're headed for a shoot-out a lot bigger and uglier, but Ben Johnson, Warren Oates, William Holden and Ernest Borgnine were clearly set up in Sam Peckinpah's *The Wild Bunch* to look like the Earp brothers and John Henry "Doc" Holliday on their walk down.

— COURTESY WARNER BROS. —

***Tombstone* (1993)**

For historical accuracy in positioning (Doc Holliday on the right flank, with Wyatt Earp on the left) and authenticity in clothes, this shot from *Tombstone* is spot-on. The building on fire behind them makes the boys look like they just walked out of hell—and hell's comin' with them. Kurt Russell has a long-barreled Colt in his right pocket. Curiously, he's the only Wyatt Earp in movies ever to have carried one to the gunfight, even though testimony at the coroner's inquest indicated that Wyatt did indeed carry a 10 ½-inch gun.

— COURTESY BUENA VISTA PICTURES —



Gunfight at the O.K. Corral (1957)

Burt Lancaster's Wyatt and John Hudson's Deputy Virgil—Wyatt was the marshal in this telling of the tale—carry two shotguns, but then, they're headed for a bunch of Cochise County Cowboys (including John Ireland's Johnny Ringo) that is practically platoon strength. The lot in which they clash is the same one at Old Tucson where John Wayne, Ricky Nelson, Dean Martin and Walter Brennan rout the bad guys in 1959's *Rio Bravo*.

— COURTESY PARAMOUNT PICTURES —



Hour of the Gun (1967)

John Sturges directed this darker, more accurate version than his previous Earp film, *Gunfight at the O.K. Corral*. Jason Robards is old enough to be Doc's father, but he wields a mean shotgun as the deadly dentist. James Garner, this film's Wyatt, also played an older and considerably lighter Wyatt in 1988's *Sunset*.

— COURTESY UNITED ARTISTS —

Four Brothers (2005)

In the most urban setting of all O.K. Corral walk downs, Mark Wahlberg and his brothers—that's right, brothers—head to a confrontation Earp-style to avenge the death of their mother. They tuck their guns in their back waistbands.

— COURTESY PARAMOUNT PICTURES —



Wyatt Earp (1994)

For sheer grimness, this walk to the O.K. Corral in *Wyatt Earp* is unsurpassed. To look at those faces, you'd think these guys were climbing Mount Everest instead of walking a block-and-a-half to that open lot next to C.S. Fly's photography studio.

— COURTESY WARNER BROS. —



"Doc" (1971)

Harris Yulin as Wyatt (far left) and Stacy Keach (left) as Doc carry double-barreled shotguns in preparation for mowing down the Clantons and McLaurys in this Vietnam-era

parable of the Earps-Cowboy war. (Screenwriter Pete Hamill suggested an unsubstantiated homosexual relationship between Wyatt and Doc, the only writer to do so until Andrew C. Isenberg in his 2013 book, *Wyatt Earp: A Vigilante Life*.)

— COURTESY UNITED ARTISTS —



Anchorman: The Legend of Ron Burgundy (2004)

Paul Rudd, Will Ferrell, David Koechner and Steve Carell head for the lot to face foes more ruthless than any ever encountered by Wyatt and Doc: reporters from competing networks, including public television and Spanish-language news.

— COURTESY PARAMOUNT PICTURES —

LITTLE KNOWN CHARACTERS OF THE OLD WEST

Big Wheel on the River

The man who taught Mark Twain how to pilot a steamboat built a northwestern empire.

Born June 6, 1822, in Springboro, Ohio, John C. Ainsworth was orphaned at 11, quit school at 13 and worked in his uncle's country merchant store. A partnership with his uncle to buy a steamboat in 1844 ignited his lifelong career.

In his 20s, he took command of that steamboat, running it for five years. Around 1850, he met and tutored 15-year-old Sam Clemens (yes, author Mark Twain!) on the finer points of river boating on the Mississippi River.

Then Ainsworth sold out. With his entire capital of \$900, he set out west, landing first in San Francisco, California, on June 23, 1850, where, unable to find work on steamboats, he went to Sacramento and clerked for the county. Later that year, on September 1, he landed in Oregon. He built a house, a fine example of Greek Revival architecture, that still stands in Oregon City.

In 1858, the steamer *Venture*, on her maiden voyage, drifted over the Columbia River's Upper Cascades, a rough section that steamboats could not navigate. It wrecked. After being hauled out and repaired, the steamer was renamed *Umatilla*.

Ainsworth bought one-third interest in *Umatilla* and took her to Fraser River in British Columbia, to transport miners and supplies. Fort Hope was the highest point ever reached by steamer. Twelve miles upstream was Fort Yale, which had only been reached by canoe. Ainsworth successfully took his *Umatilla* where no steamboat had dared to go before, to the delight of miners who lined the banks to cheer her on, whooping and firing their guns in the air.

Ainsworth also reached the upper Fraser River country via another untried route, into Harrison Lake. After these two Fraser River

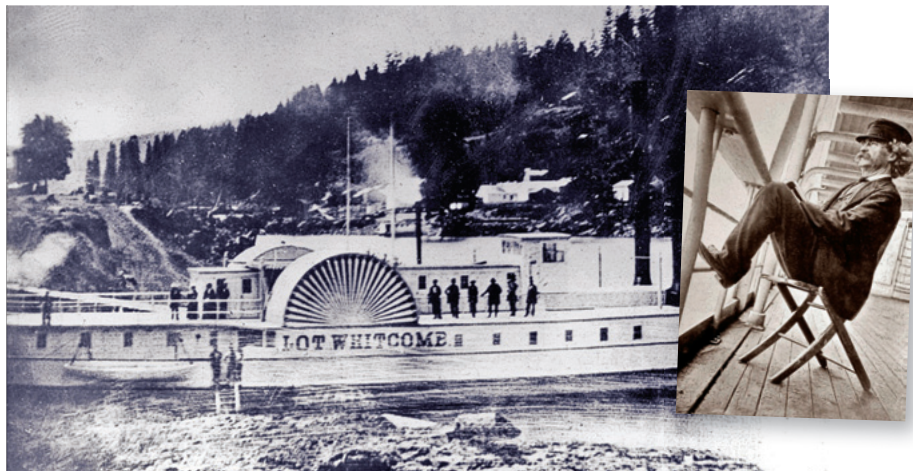

John C. Ainsworth tutored Samuel Clemens, who grew up on the banks of the Mississippi River, on the art of riverboating. The lad became a famous author (inset) under the pen name Mark Twain, a riverboat measurement term for two fathoms (12 feet). Then Ainsworth headed west, where he constructed the *Lot Whitcomb* (above) on Oregon's Willamette River before he began building his own steamboat empire.

— LOT WHITCOMB PHOTO COURTESY OREGON HISTORICAL SOCIETY; TWAIN PHOTO TRUE WEST ARCHIVES —

firsts, he stayed long enough to help establish transportation for miners and supplies before he returned to Oregon.

In the spring of 1859, Ainsworth's career on the Columbia River began in earnest with the maiden voyage of the steamer *Carrie Ladd*. At that time, the river could only be navigated from Portland to the Cascades and then from above the Cascades to The Dalles. All freight and passengers had to travel past the Cascades by a tramway. Ainsworth waded into these confused waters and created order out of chaos. Some called him a monopolist. He was an opportunist with a genius for organization and business.

The Oregon Steam Navigation Company emerged, with Ainsworth at its head. He bought the tramway over the Cascades and established a respected fleet on the

Columbia. The company made its stockholders wealthy men.

Ainsworth got in on the ground floor, cashed in on the best years and then retired from steamboating a multimillionaire. He founded the Ainsworth National Bank in Portland, the forerunner of U.S. National Bank. He retired to Oakland, California, where he built his Rose Lawn estate and founded Redondo Beach. He lived out the rest of his 71 years until he died on December 30, 1893.

The innovative pioneer lives on in history, thanks to his timely arrival during the gold rush era, which led him to create a powerful steamboat empire that helped build up America's northwestern frontier. ✦

Dulcimer Nielsen is an internationally published author and currently has seven eBooks on Amazon, including a true life story about a cowboy. Captain John C. Ainsworth was Dulcimer's great-grandfather.

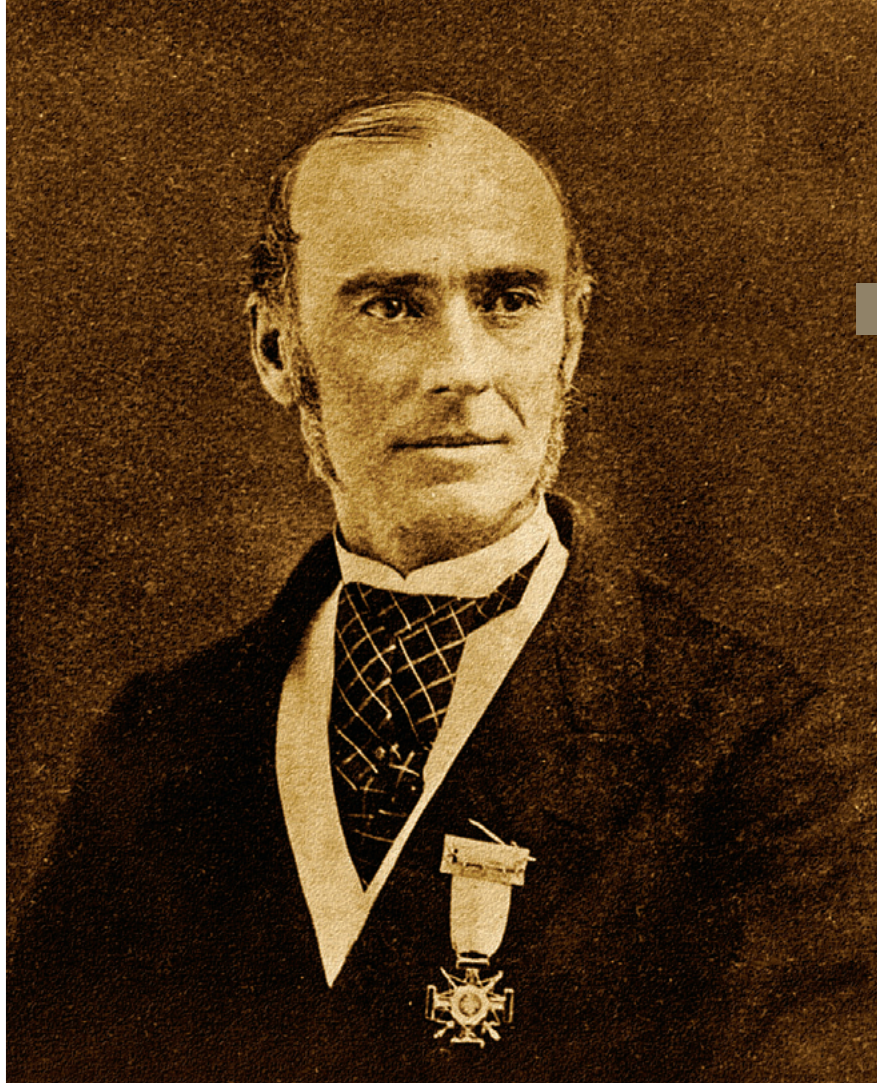

JOHN C. AINSWORTH

A savvy industrialist, John C. Ainsworth (left, circa 1864) owned the most powerful transportation monopoly in the Pacific Northwest. With the proceeds he got from the sale of the *Lot Whitcomb*, the captain purchased a stern wheel boat, the *Carrie Ladd*, which he ran to the cascades of Columbia until 1862, when the rush to mine gold on Idaho's former Nez Perce lands brought more business than boats could carry. To take advantage of the transportation needs, he partnered with others to consolidate all the boats on the Columbia River and formed the Oregon Steam Navigation Company, which ultimately made Ainsworth a multimillionaire.

- COURTESY OREGON HISTORICAL SOCIETY -

A steamboat disaster turned into a boon for John C. Ainsworth when he invested in the *Umatilla* (right), which entered the record books when the steamer dared to go where no other had gone before. On July 21, 1858, she made the trip from Fort Hope to Fort Yale in five hours, one of which was spent aground, reaching the highest point.

- COURTESY OREGON HISTORICAL SOCIETY -

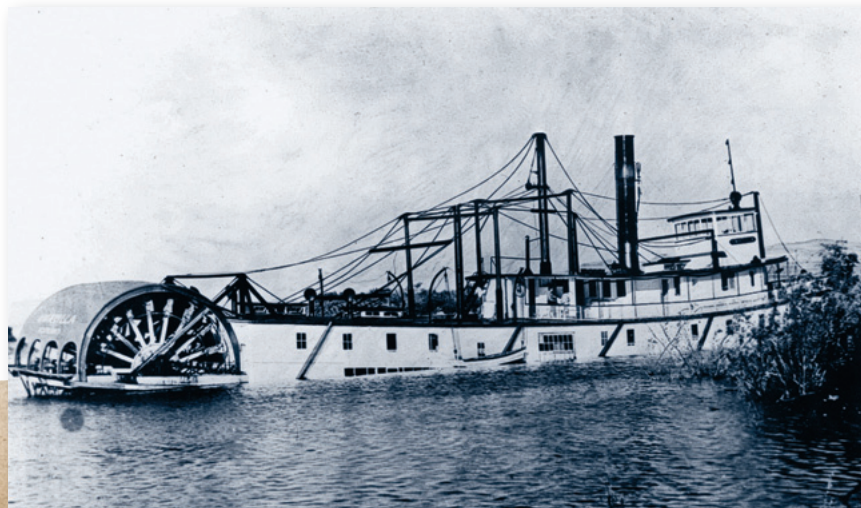

On the northern bank of the Snake River in Washington, the Northern Pacific Railroad placed a depot in Ainsworth (left), named after the president of the Oregon Steam Navigation Company. Platted in 1879, the town became home to Chinese laborers who worked for the railroad.

- COURTESY FRANKLIN COUNTY HISTORICAL SOCIETY, PASCO, WA -

BY TERRY A. DEL BENE

Lost in the Wilderness

A tax assessor must find a way to survive after his vacation in Yellowstone goes horribly wrong.

In 1870, descriptions of the natural wonders from the Yellowstone area were often seen as fantasy. Truman C. Everts, age 54, joined the Washburn Expedition, the second of three important explorations of Yellowstone, to find out if the wonders were real. The former assessor of Internal Revenue for Montana, Everts was an unlikely explorer, and he approached the expedition as a vacation.



Truman C. Everts

In September, the 19-man expedition was exploring the territory around Yellowstone Lake in present-day Wyoming. The nearly impenetrable forests made occasional separations between group members almost routine. On September 9, Everts found himself alone. Believing he knew the way, he rode on. As night fell, his companions fired signal shots, but Everts never heard them.

On September 10, Everts continued riding through the dark forest, confident that he would reunite with the party. When he dismounted to assess the path, his startled horse ran away, taking with him Everts's survival gear. He was left with only the contents of his pockets (knives, a fishhook and opera glasses) and the clothes on his back.

A cold, fireless night slumbering upon pine needles convinced Everts that he might be in danger. In the meantime, his companions continued to search for him, but Everts had wandered beyond where they believed him to be.

Henry Washburn had previously recommended a rally point at the hot springs on the southwestern arm of Yellowstone Lake for anyone who got lost. Everts got

turned around while trying to locate it, a circumstance that became clear to him when he reached Heart Lake.

Instead of heading toward the rally point, he remained for days, impotently watching a smorgasbord of mammals and huge flocks of game birds as his hunger deepened. He fretted about being captured by Indians, but soon prayed for Indians to find him.

The first of many hallucinations crept into his mind as he envisioned a pelican to be an Indian paddling a canoe.

Everts stayed alive by eating thistles, a species that was later named in his honor, scavenging the wing of a gull and by eating a snowbird he had caught. His ordeal lasted weeks and encompassed about as wide a range of survival situations as experienced outdoorsmen encounter in a lifetime. He suffered through storms, freezing nights,

close encounters with wildlife and injuries. All through this, the staggering beauty of Yellowstone never ceased to enthrall Everts.

During his ordeal, Everts escaped a mountain lion by climbing high up in a tree. The cougar circled at the base of the trunk while the terrified Everts shouted and pounded sticks in attempts to frighten the beast. He clung to his perch as the creature roared out of the dark at him for hours before it left for easier prey.

Staying near the hot springs, he used them for warmth and to cook his thistles. One night, the crust around a vent collapsed and the steam scalded his hip. This painful injury required him to sleep sitting up.

Everts had not yet come up with a way to create fire. Then he figured out that, on sunny days, his opera glass lens could ignite fire. The ability to make fire was a blessing and a curse. One night, popping and crackling noises awakened him. His campfire had spread to the trees. He was surrounded by a ring of flame, with his left hand badly burned and hair mostly singed off. Everts barely escaped with his life, and in his starvation-induced, dreamlike view of



Everts became widely known after publishing a series of articles, in *Scribner's Monthly*, chronicling his account of the 37 days he spent alone in the Yellowstone wilderness.

— ALL IMAGES TRUE WEST ARCHIVES UNLESS OTHERWISE NOTED —

existence, he saw the episode as “terribly beautiful.” The fire cost Everts his knives and fishhook.

As the days went on, Everts continued to suffer from “strange reveries” of the imagination. He hallucinated Indians, forest monsters and ghosts. He imagined his limbs and organs had changed into companions with whom he would converse and argue. While in the depths of his hallucinations, he chanced a unique survival technique. Finding a bear’s den, he built a fire around it and spent the night peacefully slumbering within as the fire spread to the forest all around.

Thirty seven days into his ordeal, on October 16, during a sleet storm, Everts

He fretted about being captured by Indians, but soon prayed for Indians to find him.

had a vision that turned out to be real—reward seekers Jack Baronett and George A. Pritchett. They rescued the delirious, 55-pound walking skeleton and took him to safety.

Everts later wrote of his ordeal and of the natural wonders of Yellowstone. Apparently none the worse for wear, he lived into his 80s, siring a child at the age of 75. What started out as a vacation in one of America’s most famous vacation places today had become one of the most celebrated survival experiences in the West.



Terry A. Del Bene is a former Bureau of Land Management archaeologist and the author of *Donner Party Cookbook* and the novel *Dem Bon'z*.

Nathaniel P. Langford, one of the principle chroniclers of the 1870 Washburn Expedition, became our nation’s first National Park superintendent, in 1872.



This William Henry Jackson photo shows a geological survey pack train making its way along the Yellowstone River in 1871. Jackson, along with painter Thomas Moran, was a member of Ferdinand Hayden’s expedition into Yellowstone. The images that Jackson and Moran brought back to civilization were instrumental in the designation of Yellowstone as America’s first national park.

— COURTESY LIBRARY OF CONGRESS

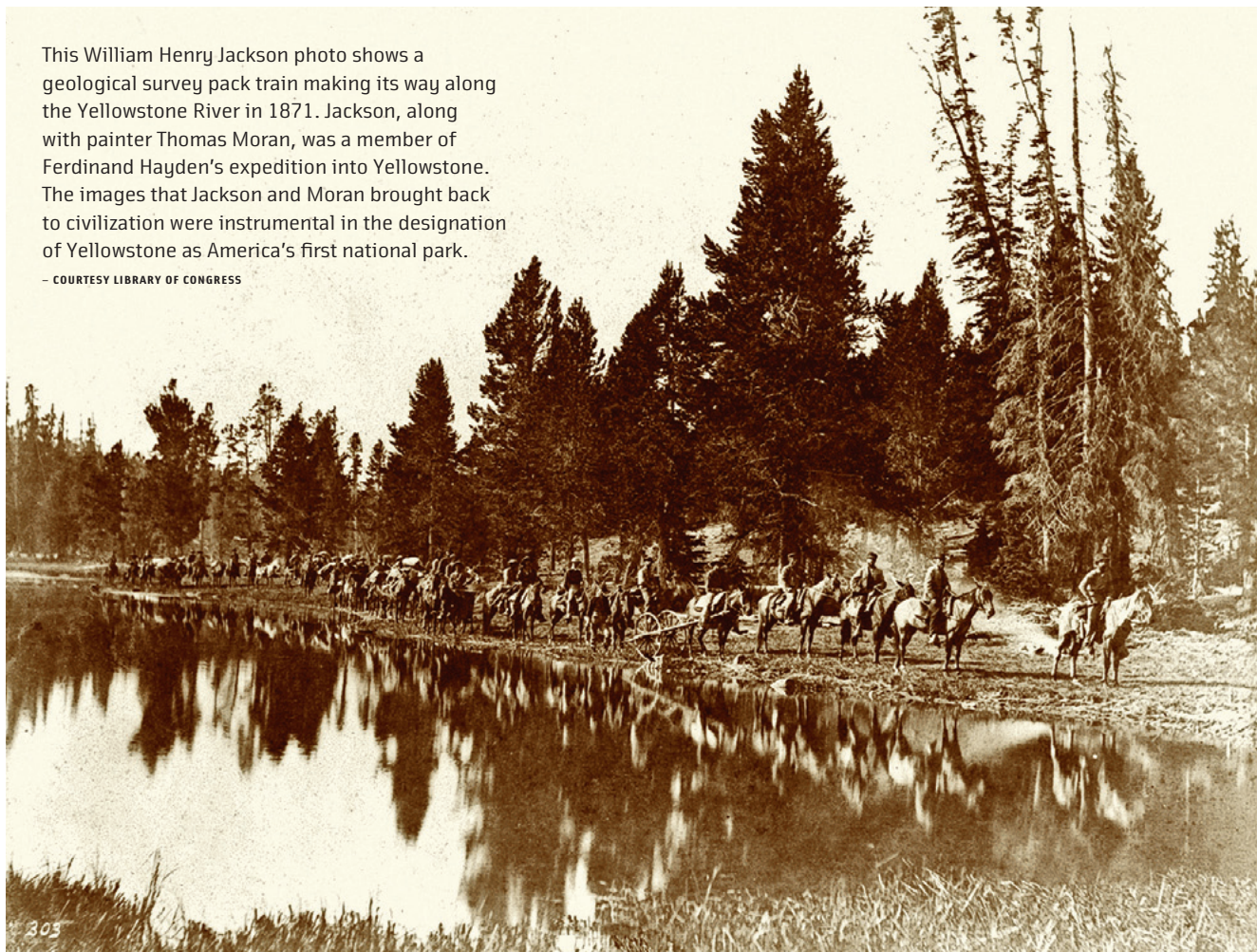

On the Trail of the Rocky Mountain Fur Company

A cross-country adventure awaits the traveler following in the footsteps of the mountain men.



The iconic Teton Range in Grand Teton National Park towers above modern-day Jackson Hole, Wyoming. The jagged mountain range is a natural landmark that was a crossroads of American Indians, Europeans and Americans during the fur trapper era.

— COURTESY CAROL M. HIGHSMITH, LIBRARY OF CONGRESS —

A hundred young men walked into the Rocky Mountains and became legends of the West when they responded to William Henry Ashley's call for adventurers to go into the beaver trade in 1822. Ashley advertised in St. Louis for men to work the beaver streams of the West, and the following year the first of these young

men made their way to the Upper Missouri and ultimately spread out along the streams that flowed from the Rocky Mountains.

They began trapping for beaver and quickly launched a true mountain tradition. They held their first mountain trading fair—or Rendezvous—in 1825 in the southern end of the Green River Valley at Burnt Fork, in what is now Wyoming. The annual

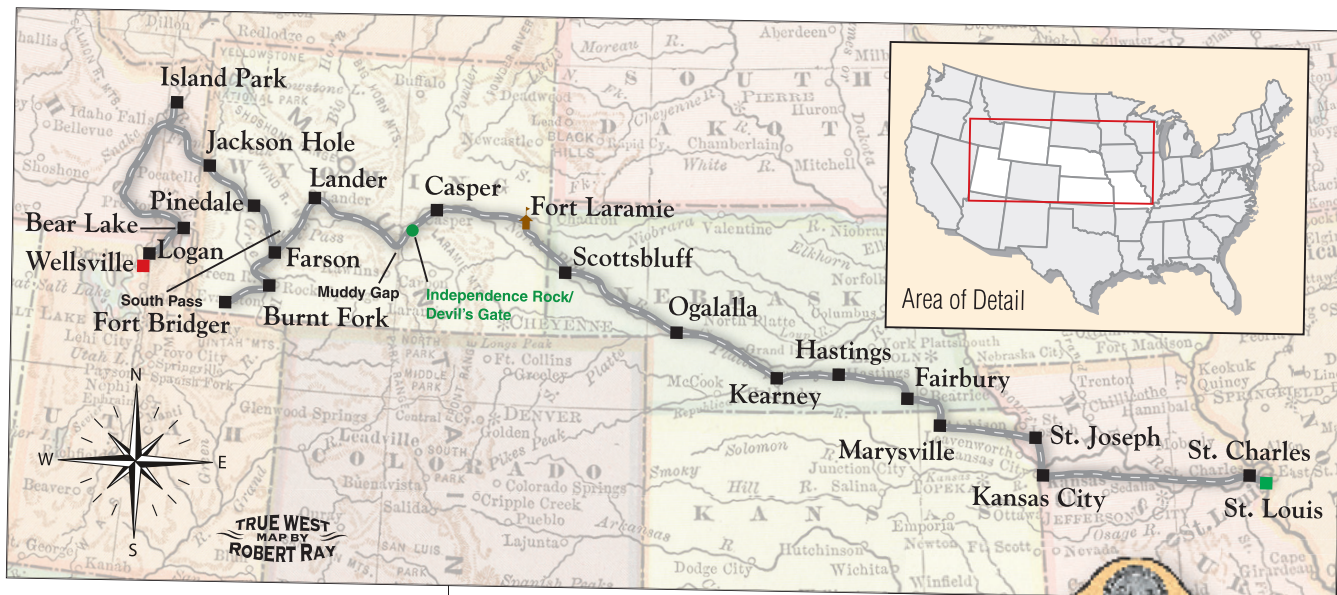

Rendezvous quickly expanded and would ultimately attract hundreds of mountain men, Indians and traders. These gatherings moved around to differing locations, but always were places of trade, business deals, entertainment and revelry.

The Rocky Mountain Fur Company was born at the 1830 Rendezvous when then-veteran mountain men Jim Bridger, Milton Sublette, Henry Fraeb, John Baptiste Gervais and Thomas Fitzpatrick purchased the outfit that had been organized by Jedediah Smith, David Jackson and William Sublette.

All the men had been a part of the original 100 hired by Ashley in 1822. They had spent the intervening years tramping throughout the West, following game and Indian trails, making

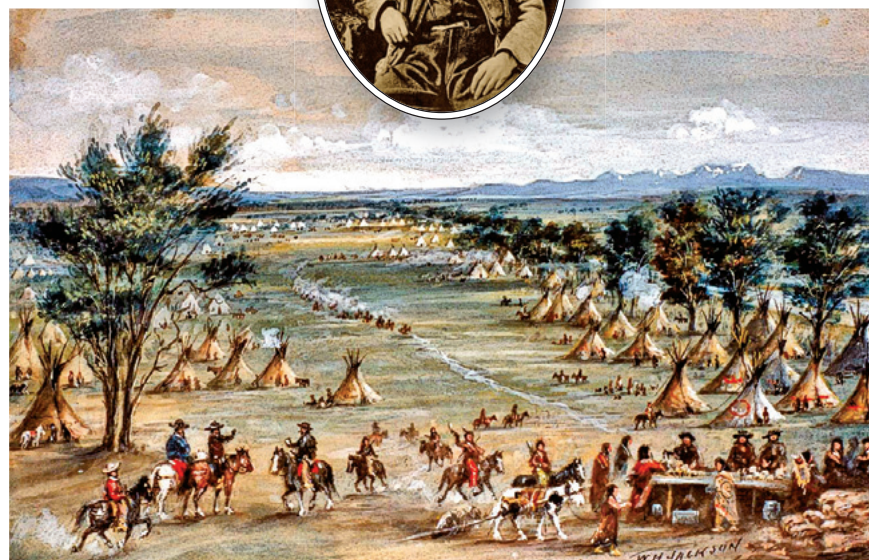

maps and trapping the valuable beaver.

The men of Rocky Mountain Fur made their mark on the industry and left their names on physical landmarks including Fort Bridger, the Fitzpatrick Wilderness and Sublette County.

It's too much to try to follow all their trails in the West, so we'll hit a few locations that were either frequented by the fur trappers, or that recognize their legacy.

Gateway to the West

We'll begin in St. Louis, where Ashley found his mountain men. This city is awaiting the reinstallation of the exhibits at the Jefferson National Expansion Memorial at the Gateway Arch, which are expected to reopen in 2017.

Historical Marker Fort Nonsense

Named for Captain Benjamin Bonneville, Fort Bonneville, was established in 1832 in the upper Green River Valley, and became better known as Fort Nonsense or Bonneville's Folly. Its location was convenient to the mountain man Rendezvous held in the region, but the high mountain location meant that it was extremely cold in winter. Though a center of trading during the 1833 Rendezvous, and used for storage of goods at the 1836 Rendezvous, the severe winter weather quickly led to the fort's abandonment.

Our route heads west to St. Charles, Missouri, with its enticing historic district.

St. Charles was Missouri's first state capital, established in 1821, just a year before Ashley was advertising for men to ply the fur trade. While places in St. Louis served as headquarters for territorial government activities, some locations were considered to become the permanent seat of government as Missouri approached statehood. Jefferson City was selected, but the state needed an interim location for its first legislative sessions. Legislators met in St. Charles for the first time on June 4, 1821.

One of the most well known of Ashley's 100, Jim Bridger (above left) trapped and traded from his earliest days in the West beginning in 1823. He would later join partner Louis Vasquez in starting Fort Bridger.

- COURTESY UTAH STATE HISTORICAL SOCIETY -

William Henry Jackson's painting titled *Rocky Mountain Rendezvous* illustrates the carnival atmosphere of the gatherings of trappers, traders and Indians held from 1825 to 1840.

- COURTESY WILLIAM HENRY JACKSON COLLECTION, SCOTTS BLUFF NATIONAL MONUMENT, NPS.GOV -



The Robidoux family had long ties to the fur trade industry in St. Louis, and opened a trading post in the vicinity of Scotts Bluff to serve fur traders, Indians and, later, emigrants. This replica of the second Robidoux post stands near Robidoux Pass.

- PHOTOS BY CANDY MOULTON -

TO
Enterprising Young Men.
 THE subscriber wishes to engage **ONE HUNDRED MEN**, to ascend the river **Missouri** to its source, there to be employed for one, two or three years.—For particulars, enquire of Major Andrew Henry, near the Lead Mines, in the County of Washington, (who will ascend with, and command the party) or to the subscriber at St. Louis.
Wm. H. Ashley.
 February 13 —98 tf

This advertisement attracted young men who would make their mark as fur trappers, traders and, later, businessmen in the West.

Debates on issues of states rights and slavery dominated the early sessions held in the House and Senate chambers on the second floor of a new structure built by Charles and Ruluff Peck, who operated a general store in the first floor rooms. The second floor of the building, in addition to the legislative chambers, also held an office for the governor and a small committee room. This first state capitol served four Missouri governors until a new capitol was built and opened in Jefferson City in 1826.

The historic district surrounding this first capitol has plenty to see, including buildings that date to the 18th and 19th century, and Lewis and Clark and fur trade history, but it's time to head west through Independence and Kansas City. This is country marked by the starting points of overland trails to Oregon and California, routes established by tracing the footsteps of mountain men.

Ashley's trappers followed the Missouri River north, but the trade brigades heading to Rendezvous went overland across Kansas and Nebraska, following the Platte and North Platte rivers.

Trails West along the Platte

In 1828 in far western Nebraska fur trapper Hiram Scott lost his life at a sandstone outcrop that now bears his name, Scotts Bluff. In the pass to the south stands a replica of the Robidoux Trading Post,

COWBOY DAYS
 FRI, SAT. & SUN., SEPT. 2ND, 3RD & 4TH
 SADDLE UP AND JOIN US FOR THE FUN!
EVENTS
 • BOURBON TRAIN • PARADE OF BREEDS • SPECIAL CONCERT
 • LONGHORN CATTLE DRIVE DOWN MAIN • PETTING ZOO
 • HORSE DRAWN CARRIAGE RIDES • FILM FESTIVAL
 • COWBOY OF THE YEAR AWARD • TEXAS HOLD'EM TOURNAMENT
 • OVERNIGHT HORSE CAMPING, TRAIL RIDE & COWBOY CHURCH

COUNTRY MUSIC LIVE IN CONCERT
Mickey Gilley
 TICKETFLY.COM

HOLD ON TO YOUR HATS!!!
 SATURDAY, SEPT. 3 • 11 A.M.
 LONGHORN CATTLE DRIVE & PARADE OF BREEDS DOWN MAIN STREET OTTAWA, KS.
Mechanical Bull Riding Competition!

PLAZA CINEMA
 MOVIE MEMORABILIA MUSEUM
 OLDEST OPERATING CINEMA IN THE WORLD EST. 1905
 Enjoy current and historic movies daily, or tour our museum of props, scripts and posters from your favorite film. Visit **OttawaPlazaCinema.com** for shows and showtimes.

Astride the Emigrant Trail south of the North Platte River, Scotts Bluff National Monument, near Scottsbluff/Gering, Nebraska, protects the natural landmark and the historic Western route that over 500,000 settlers and missionaries crossed on their way West.

— COURTESY NEBRASKA TOURISM —



which was established at the end of the fur trade era and bridged the era of the overland migration. Walking through Mitchell Pass at Scotts Bluff, or in the area of Robidoux Pass, you'll get a sense of the landscape fur trappers first saw when they were here in the early 19th century.

One of the best museums in the country devoted to the story of the mountain trade, the Museum of the Fur Trade in Chadron, Nebraska, has outstanding examples of trade goods, supplies and original garments. Located on the actual site of an American Fur Company trading post operated by James

Bordeaux, a replica is stocked much as it would have been when it opened in 1837.

The early fur trade post of Fort William, established by Robert Campbell and William Sublette in 1834, predated Fort Laramie, one of the most important sites of the fur trade and overland trail era. This National Historic Site includes fur trade and trail history and focuses on the early military history of the area.

Thomas Fitzpatrick, one of the owners of RMF, has strong connections to this area. He guided the first wagon train over the Oregon Trail in 1841 and also led John C. Fremont's first expedition into the West through here in 1843. When the first big gathering of Plains Indians took place nearby in 1851, Fitzpatrick was involved with the negotiations. Although that treaty council gathered near Fort Laramie, the 10,000 people and their animals

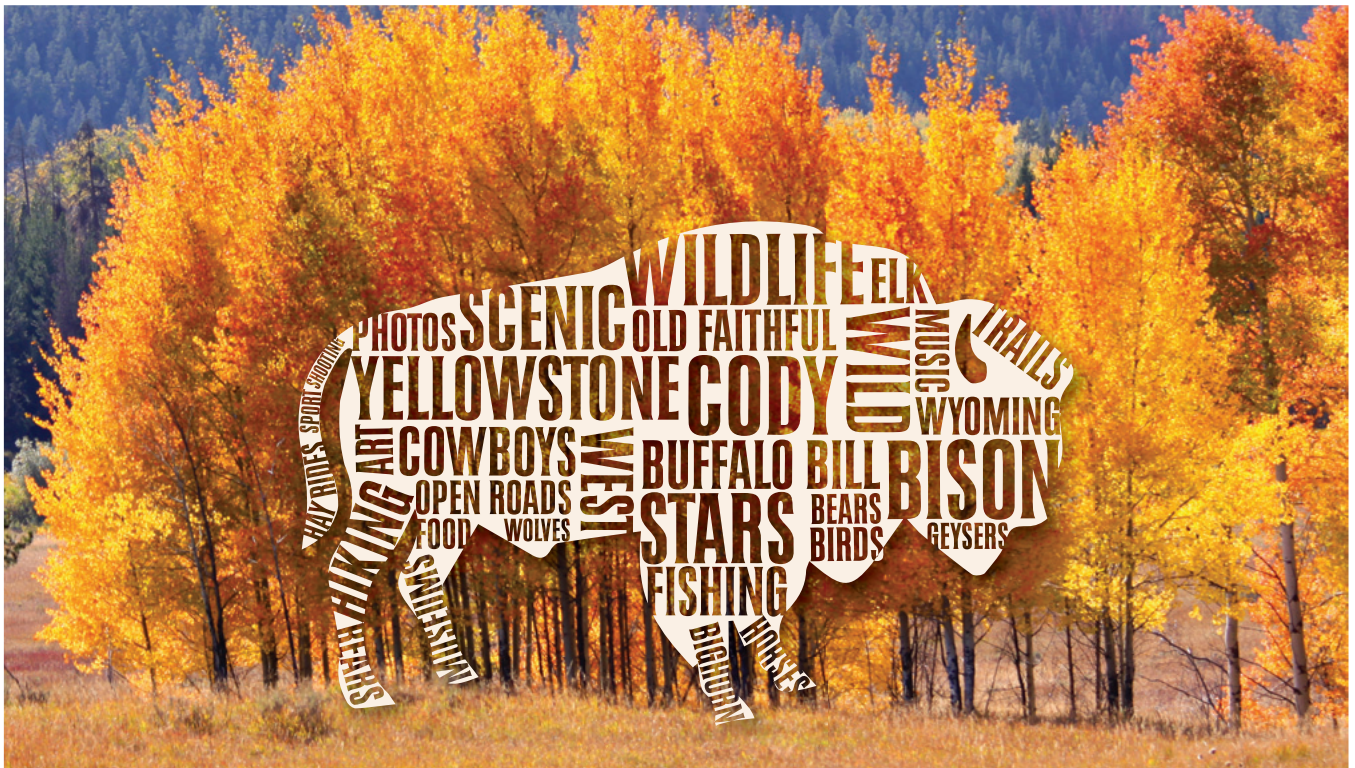

FULL OF SCENERY. There's plenty to see and do. Start planning your fall getaway to Cody, Wyoming today. **1-800-393-2639** or **yellowstonecountry.org**.



THE WILDEST WAY INTO YELLOWSTONE

Knicht Museum and Sandhills Center

On the edge of the
Nebraska Sandhills.

A Railroad town.

A Cow-town.

An Ag town.

Where history
runs deep.

Largest Genealogy
Center in Western
Nebraska

Alliance
Nebraska®

Building the Best Hometown in America

KnichtMuseum.com



Bear Lake on the Idaho/Utah border is one of the locations where mountain men of the 19th century gathered for Rendezvous. Gatherings are still held in the area.

- CANDY MOULTON -

26th Annual All American GUN & WESTERN COLLECTABLE SHOW

Ruidoso, New Mexico

9:00 AM to 5:00 PM Saturday & Sunday
September 3 & 4, 2016
at the Ruidoso Convention Center

575-257-6171

www.trekwest.com/gunshow

Buy • Swap • Sell • or Just Look
Lots of Guns • Gun Related Items • Cowboy Gear
Saddles • Spurs • Western Artifacts

Adults \$6.00
Kids Under 12
FREE



Proceeds Benefit Lincoln County Charities
No one under 18 admitted without parental supervision.

soon overwhelmed the landscape and the group moved downstream to near Horse Creek, which gave the treaty they negotiated its name.

Across the Rockies

Our route crosses Wyoming (US 26/I-25 to Casper, then Wyoming 220 to Muddy Gap/US 287 north toward Lander then Highway 28 west across South Pass). Although Robert Stuart first located this pass in 1812, Jediah Smith and Thomas Fitzpatrick would be the first to ascend the pass from the east and take wagons across.

Once west of the Continental Divide, our route turns south to Fort Bridger, a trading post established by Jim Bridger and his partner, Louis Vasquez. Undoubtedly the best time to visit here is over Labor Day weekend during the annual Fort Bridger Rendezvous

that attracts hundreds of modern-day mountain men, mountain traders and Indians who re-create the days of the Rendezvous.

Continue on to the Bear Lake area on the Idaho/Utah border and to Wellsville, Utah, to visit the American West Heritage Center, where you will find a mountain

man camp, and occasional interpreters who themselves participate in modern Rendezvous at Bear Lake or Fort Bridger.

Sublette County, Wyoming, takes its name from William Sublette who with David Jackson and



Wyoming's South Pass State Historic Site, a National Historic Landmark,

protects the natural route over the Wind River Range, and the abandoned mining town built adjacent to the emigrant trail to the West.

- COURTESY LIBRARY OF CONGRESS -

Side Roads



Trade goods are on display inside the replica trading post at the American West Heritage Center in Wellsville, Utah.

— PHOTOS BY CANDY MOULTON —

The annual Fort Bridger Rendezvous attracts traders who, in the best tradition of Rendezvous, bring goods to exchange with modern-day buckskinners needing a new garment.



Jedediah Smith organized the fur company of Smith, Jackson, and Sublette—the precursor to Rocky Mountain Fur Company. This area hosted seven mountain man Rendezvous on Horse Creek, near the tiny town of Daniel. The Museum of the Mountain Man in Pinedale represents this history and displays one of Jim Bridger's original rifles.

Jackson Hole is named for David Jackson, another of the partners in the Smith, Jackson, and Sublette enterprise. Each year over Memorial Day weekend a mountain man trader camp sets up at the Jackson fairgrounds. The Jackson Hole landscape—while completely filled with tourists—is still a place of natural breathtaking views and wildlife common when Smith, Jackson and Sublette first trapped here. Any drive through Jackson Hole might give you an opportunity to see bison, elk, deer, antelope and even grizzly bears or wolves, not to mention creeks, rivers, lakes and spectacular mountains.

The mountain trappers and fur brigades also gathered in Pierre's Hole, an area now known as Island Park, Idaho. As you travel to these various trapping and Rendezvous sites—Bridger Valley, Horse Creek, Bear

Lake, Jackson Hole and Pierre's Hole (Island Park), you'll quickly recognize one thing: The mountain men knew how to select gathering spots that offered abundant natural resources and great beauty.

Rocky Mountain Fur Company, while owned and managed by some of the best trappers in the business, was never a huge financial success and faced stiff competition from the older Hudson's Bay Company and the successful American Fur Company. While the RMF trappers succeeded in their pursuit of beaver furs, ultimately, the company failed, followed by the demise of the fur trade itself.

The 100 men Ashley recruited had a lasting impact on the region, as they created maps, guided later travelers, established business enterprises, forged relations with American Indians and ultimately left their names all across the mountain West. 

Candy Moulton lives near Encampment, Wyoming, a community named for a small gathering of fur trappers in 1838 whose Rendezvous beside the river was called Camp le Grande—The Grand Encampment.



Green River Rendezvous, Pinedale, Wyoming

CELEBRATIONS & EVENTS

Bear Lake Rendezvous, held each August near Bear Lake, Idaho; **Fort Bridger Rendezvous** has traders, Indian dancers and mountain man camps at Fort Bridger State Historic Site, *Labor Day weekend*; **Fur Trade Days**, held the *second weekend in July*, at the Museum of the Fur Trade in Chadron, Nebraska, includes a Fur Trade Flag Ceremony that recognizes the companies and countries involved in the North American fur trade.

PLACES TO VISIT

First Missouri State Capitol, St. Charles, MO; **Museum of the Fur Trade**, Chadron, NE; **Robidoux Trading Post**, Gering, NE; **Fort Laramie**, Fort Laramie, WY; **Museum of the Mountain Man**, Pinedale, WY; **Fort Bridger State Historic Site**, Fort Bridger, WY; **American West Heritage Center**, Wellsville, UT; **Jackson Hole Museum**, Jackson, WY

GOOD EATS & SLEEPS

Best Grub: *Ophelia's Restaurant*, Independence, MO; *Whiskey Creek Wood Fire Grill*, Scottsbluff, NE; *Armor's Silver Fox*, Casper, WY; *Gannett Grill*, Lander, WY; *The Bunnery Bakery & Restaurant*, Jackson, WY; *Wort Hotel Silver Dollar Bar & Grill*, Jackson, WY; *Pond's Lodge*, Island Park, ID

Best Lodging: *Embassy Suites*, St. Charles, MO; *Hampton Inn*, Scottsbluff, NE; *Chambers Inn*, Pinedale, WY; *Jenny Lake Lodge*, Jackson Hole, WY

GOOD BOOKS, FILM & TV

Best Reads: *Give Your Heart to the Hawks* by Win Blevins; *A Majority of Scoundrels: An Informal History of the Rocky Mountain Fur Company* by Don Berry; *A Life Wild and Perilous* by Robert M. Utley; *Fur, Fortune, and Empire: The Epic History of the Fur Trade in America* by Eric Jay Dolin; *The Revenant* by Michael Punke.

Best Film, Music and TV: *The Revenant* (20th Century Fox, 2015); *Seekers of the Fleece* from A Ballad of the West trilogy by Bobby Bridger (White Coyote Music, 2000); *The Mountain Men* (Columbia Pictures, 1980); *The Big Sky* (RKO Radio Pictures, 1952); *Across the Wide Missouri* (MGM, 1951); *Man in the Wilderness* (Warner Bros., 1971).

BY SHERRY MONAHAN

Eating Out

Restaurants on the frontier got finer as the towns around them grew.

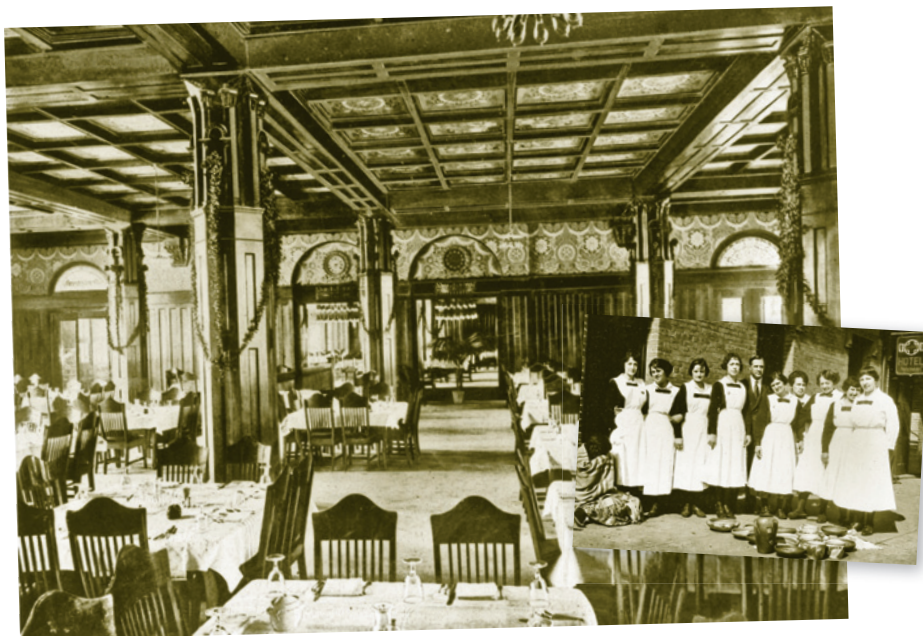

Fred Harvey started the most famous eating establishments out West, including one at Union Station in St. Louis, Missouri (top). His waitresses, known as Harvey Girls, were a pleasing sight to behold (such as these Arizona gals, right), especially when so many pioneer men lived among so few women.

— TOP COURTESY ST. LOUIS UNION STATION ARCHIVES; ABOVE COURTESY WINSLOW HISTORICAL SOCIETY'S OLD TRAILS MUSEUM —

A basic necessity in frontier camps, restaurants often started out in tents. An evolution took place as wagons rolled west and pioneers arrived to put down roots. Permanent structures replaced tents and shanties, and supplies began rolling in via steamboats, stage-coaches and railroads.

In the early days, especially in remote locales, menus offered simple fare: local game, chicken, beef, potatoes, bread, cake, pie or pudding and coffee and tea. But as early as the 1850s, some locations, including Bellevue City, served up impressive meals. Situated on the banks of the Missouri River, the Nebraska Territory town offered its chefs provisions from steamboats docked nearby.

The bill of fare for dinner at Bellevue House on July 5, 1857, was the talk of the

Bellevue Gazette: “He who has an idea that we have nothing to eat out here in the ‘back woods’ would be astonished, if on his way through he would stop at the Bellevue House, kept by J.T. [Allan].”

The impressive and vast menu included: boiled chicken with egg sauce, leg of mutton with caper sauce, macaroni cheese, veal fillets, deviled ham, chicken a la cardadelle, scalloped tongue with Worcestershire sauce and beef heart fricasseed with Redding sauce. Dessert came in the form of six pies, three puddings and fruits and nuts, which could be served with champagne, wine, madeira, port, sherry, London porter, Scotch ale or Pittsburgh ale.

Much like folks do today, pioneers out West kept up with food trends. Classic French cooking was popular during the

“...we have nothing to eat out here in the ‘back woods....”

- Outdoor Adventure in the incredible San Juan Wilderness
- Travel Adventure on the historic Cumbres & Toltec Scenic Railroad
- Adventures in History along Los Caminos Antiguos Scenic Byway

Explore the Possibilities
Conejos County Tourism
800-835-1098
www.conejosvacation.com

**IT'S MORE THAN A RIFLE,
IT'S HISTORY!**

Genuine S. Hawken
Classic Plains Rifle
Made in the USA

www.thehawkenshop.com
The Hawken Shop® • Oak Harbor, WA
FREE CATALOG!

mid- to late 19th century. Menus were frequently printed in French and cooking styles often included the words “a la” for the particular sauce added to a dish.

Restaurant interiors ranged based on the type of fare provided. Simple furnishings, basic flatware and thick china dishes or tin plates were found in rural places, while fancy eating houses offered expensive décor with shimmering crystals, fine bone china and polished silverware.

The restaurant business was transient, mainly because of the competition. An eatery could be at the top of its game and, just two years later, be out of business. Mining towns and cowtowns saw the largest turnover because of the booms and busts. Railroad towns tended to have more stability in the restaurant business.

The Union Station railroad depot in St. Louis, Missouri, offered a restaurant that reflected all that was trendy in America. The Terminal Hotel housed one of Fred Harvey’s well-known restaurants. The specials created there included little, thin orange pancakes. Whip up some for your next breakfast!



Sherry Monahan has penned *The Cowboy’s Cookbook*, *Mrs. Earp: Wives & Lovers of the Earp Brothers*; *California Vines, Wines & Pioneers*; *Taste of Tombstone* and *The Wicked West*. She has appeared on Fox News, History Channel and AHC.

HARVEY HOUSE’S LITTLE, THIN ORANGE PANCAKES

- ¼ c. diced orange sections and juice*
- 1 tsp. grated orange peel*
- 1 c. pancake mix*
- 1 c. orange juice*

Combine all together and cook on a griddle. The recipe states, “Bake small pancakes on hot griddle, using one tablespoon butter for each pancake. Serve with maple syrup, honey or jelly.”



Recipe courtesy Stephen Fried’s
Appetite for America

Here in Dodge City, we look at life a little differently.

Out here, you can still witness a gunfight, enjoy a great steak, try your luck at the Boot Hill Casino, or watch a beautiful sunset.

Heck, we even enjoy a great rodeo every summer.

Experience the history of Dodge City, where the Marshal still roams the streets.

800-OLD-WEST www.VisitDodgeCity.org
Dodge City Convention and Visitors Bureau

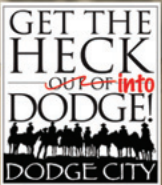
The Heart of the Big Bend Country

Study Butte/Terlingua is located three miles from the park entrance.

We offer five motels, several restaurants, medic’s, post office, bank, gas station, a great quilt shop, art galleries, assorted gift shops, and wonderful night life.

Big Bend Chamber of Commerce: 432-371-2320
bigbendchamberofcommerce.org

© Molly Dumas

WESTERN MOVIES

DVD & TV SERIES
BY HENRY C. PARKE

A Defiant Outlaw-Hero Ballad

Jeff Bridges and Buck Taylor's latest Western leaves you sympathetic to the outlaws.



You know you're in Texas when a pair of ski-masked men rob a crowded bank and nearly every customer pulls a gun and opens fire. The impromptu posse that takes off after the robbers would throw a scare into the James Gang!

Hell or High Water is the modern-day Western story of brothers who, like Jesse James and brother Frank, have problems with banks: in this case, the bank's imminent

foreclosure on Ma's ranch. Ben Foster plays Tanner and is as frightening here, as a gregarious fellow, as he was playing Russell Crowe's humorless wingman in 2007's *3:10 to Yuma*. He's just out of prison, and brother Toby, played by Chris Pine (known for his role as Capt. James T. Kirk in the rebooted *Star Trek*), divorced and with sons to support, comes up with a wonderfully awful idea: raise the money for the mortgage by robbing branches of the bank that hold the paper.

Screened at the 2016 Cannes Film Festival, the movie was originally titled *Comancheria* before being called *Hell or High Water*. Ben Foster (at left) and Chris Pine (at right) play brothers who attempt a bank robbery to save their West Texas family farm.

— ALL HELL OR HIGH WATER PHOTOS BY LOREY SEBASTIAN —



A cowboy and an Indian join forces as Texas Rangers righting a wrong in the form of Jeff Bridges (at left) and Gil Birmingham (at right). Birmingham's Western credits include 2013's *The Lone Ranger*, 2011's *Rango* and 2005's *Into the West*. Bridges has never let his two big flop Westerns, 1980's *Heaven's Gate* and 1995's *Wild Bill*, keep him from being a fan of the genre. He famously said, "There are some wonderful ones still to be made."

Hell or High Water is also the story of the pair of Texas Rangers investigating the holds-ups: widowed, soon-to-be-retired Marcus (Jeff Bridges) and his esteemed, but much-badgered Comanche partner Alberto Parker (portrayed by a Comanche, Gil Birmingham—Billy Black of the *Twilight* films).

Birmingham tells *True West* he was happy to play Parker for many reasons. "It's rare that you see a character of that ethnic background portrayed in such a positive light," he says. "The natives are still here; we've been portrayed in the past as if we don't exist anymore. [This movie] had a special meaning for me because my father was a lawman for most of his career. He was a military policeman and also a Texan, so many of these aspects fell into place just automatically."

Hell or High Water is helmed by David Mackenzie, a director and writer who has elegantly tackled Crime Dramas that include 2003's *Young Adam*, Sci-Fi flicks that include 2011's *Perfect Sense* and Romantic Comedies such as 2011's *Tonight You're Mine*.

"I did have qualms about making a Western," Mackenzie tells *True West*. "Not

John Bianchi's
FRONTIER GUNLEATHER
 STARQUEST INC.

50 Years Of
 Excellence
 In Gunleather

Free Color Catalog For *True West* Readers
1-760-324-6198
www.frontiergunleather.com
 "The Standard by Which All Gunleather Is Judged"

Your source for cowboy
shooting supplies,
obsolete and cowboy
ammunition!



Outfitters to the Old West!



8am - 4:30pm M - F PST
660 Vermeer Court, Ponderay, ID 83852

208 263-6953

WWW.BUFFALOARMS.COM

SPUR YOUR SOUL

MIDWEST

IN
SCOTTS BLUFF COUNTY

VisitScottsBluff.com 800-788-9475

NEBRASKA'S LANDMARK COUNTRY
Scottsbluff · Gering

necessarily as a Scot, because many of the protagonists of the story of the West were of Scots ancestry, but as someone with a strong admiration for the great films in that genre—it's hard to follow in those footsteps. I abandoned an attempt to write a Western a few years ago because I felt like I was at the bottom of a butte in Monument Valley looking up at a genre I couldn't possibly add to. When this script came along, it was like a gift that allowed me to connect to this lineage in a fresh and interesting way."

That script is by Taylor Sheridan, who starred in FX's *Sons of Anarchy* before turning writer, stunning audiences with 2015's clever and tough *Sicario*, about an FBI agent embroiled in the drug wars at the U.S.-Mexico border.

"When I came across this script I thought it was absolutely brilliant," Birmingham says. "I was curious to know how he had the sensibilities about the native character, and it turns out he lived on the Lakota reservation for six or seven years."

One major appeal of the film is Jeff Bridges' performance as a Texas Ranger, a fitting follow-up to his Rooster Cogburn portrayal in 2010's *True Grit* and a strong addition to a half century of Western roles that began on father Lloyd Bridges' series, 1965's *The Loner*. Like John Wayne, Bridges has matured into his later Western roles, bringing layered and nuanced qualities. Says Mackenzie, "I am an enormous fan of Jeff's and his films. He was incredibly creative and a real gentleman—it's a fantastic performance with some real magic."

Birmingham says he and Bridges have a strong personal connection. "I was surprised at how similar we were—he's a very Zen kind of guy. We also connected in a major way, with music. Every time we went on the set, I can hear Jeff saying, 'Did you bring your guitar?' I said, 'We're working, Jeff. When are we going to have time?' 'Well, you never know. But if we do, we're going to jam!'"

The film's cat and mouse story, more rooted in character than elaborate plotting,

The impromptu posse that takes off after the robbers would throw a scare into the James Gang!

features a gem of a scene early on in which an old man is showing a teller a shoebox full of coins when the robbers enter the bank. The old man is Buck Taylor, Newly from CBS's *Gunsmoke*, who has taken over for the late Harry Carey Jr. and Ben Johnson as the

man you cast to prove you're making a real Western.

With two pairs of characters diametrically opposed, the question arises: Who do you root for? Birmingham's character has no pity for his quarry. "It's the Ranger creed: our job is to protect property and life. [The brothers'] motivations aren't pertinent to us," he says.

Director Mackenzie doesn't want the audience to see things quite so black and white. "It was always the intention of this film to have some sympathy for the outlaws," he says. "There's a long tradition of this sympathy in Scottish culture—the defiant outlaw-hero ballad—that was directly transplanted into American culture. I think we care about these guys because, in different circumstances, it could be us doing what they're doing."

DVD REVIEW

Broken Lance

(Twilight Time, \$29.95) The spoiled first three sons—Richard Widmark, Hugh O'Brian and Earl Holliman—of Spencer Tracy's cattleman character can't abide their half-breed, half-brother Robert Wagner, or

their Cheyenne stepmother played by Katy Jurado, in this fascinating family drama that won writer Philip Yordan an Oscar. Cinematographer Joe MacDonald made unforgettably beautiful use of Technicolor and Cinemascope in this 1954 Western, and Edward Dmytryk directed the seething passions with panache. The release includes illuminating commentary by Holliman.



Henry C. Parke is a screenwriter based in Los Angeles, California, who blogs about Western movies, TV, radio and print news: HenrysWesternRoundup.Blogspot.com



ATTENTION READERS!

To receive FREE information from our advertisers, simply make your selections from the category listing on the adjacent card.

Either mail the post-paid card or fax it to 480-575-1903.

We will forward your request. Valid until 09/30/16.

ADVENTURE

- Big Cedar Lodge p. 13
- California Trail Interpretive Center p. 99
- O.K. Corral p. 15

APPAREL & ACCESSORIES

- John Bianchi's Frontier Gunleather p. 63
- Catalena Hatters p. 104
- Golden Gate Western Wear/Knudsen Hat Co. p. 104
- Historic Eyewear Company p. 104
- Western & Wildlife Wonders p. 104

ART & COLLECTIBLES

- Heritage Auctions p. 102
- Stagecoach Gifts & Collectibles p. 76
- The Hawken Shop p. 60

EVENTS

- All American Gun & Western Collectibles Show p. 58
- Celebrate Bandera p. 96
- Cowboy Days: Ottawa, KS p. 56
- Heber Valley Western Music p. 106
- Hells Canyon Mule Days p. 111
- Heritage Days, Apache Junction, AZ p. 93
- Horse & Burro Adoption p. IFC
- Legends of the West Auctions p. 102
- National Cowboy Symposium & Celebration p. 107
- Rock Island Auction Co.'s Premiere Firearms Auction p. 3 & BC
- Texas Gun Collectors Association p. 72
- Vaquero Show & Sale p. 87
- Western Trappings on the Llano p. 20

FIREARMS & KNIVES

- A. Uberti p. 21
- All American Gun & Western Collectibles Show p. 58
- Buffalo Arms Co. p. 64
- John Bianchi's Frontier Gunleather p. 63
- Navy Arms p. 68
- Rock Island Auction Company p. 3 & BC
- Taylor's & Company p. 18
- The Hawken Shop p. 60

FOOD/BEVERAGES/LODGING

- Big Nose Kate's Saloon p. 111
- Big Cedar Lodge p. 13
- Buffalo Bill's Irma Hotel p. 88

MEDIA

- Big Lizard by Hank Johnson p. 70
- Chris Enss p. 69
- Guidon Books p. 104
- Louis L'Amour Trading Post p. 104
- Southern Son: The Saga of Doc Holliday by Victoria Wilcox p. 73
- The Far Journey: The Captured Girl by Tom Reppert p. 70

MUSEUMS

- Baker Heritage Museum p. 96
- Boot Hill Museum p. 85
- Buffalo Bill Center of the West p. 89
- Buffalo Bill Museum & Grave p. 87
- Buffalo Soldiers National Museum p. 1
- C.M. Russell Museum p. 92
- California Trail Interpretive Center p. 99
- Cave Creek Museum p. 87
- Columbia Gorge Discovery Center p. 90

- Cripple Creek District Museum p. 86
- Days of 76 Museum p. 86
- Desert Caballeros Western Museum p. 91
- Fort Smith Museum of History p. 86
- G.W. Frank Museum of History & Culture p. 75
- Harold Warp Pioneer Village p. 76
- Jesse James Farm & Museum p. 83
- Kenedy Ranch Museum p. 86
- Knight Museum & Sandhills Center p. 58
- Laura Ingalls Wilder Museum p. 93
- Mark Twain Boyhood Home & Museum p. 93
- Museum of Nebraska Art p. 75
- Museum of the Big Bend p. 98
- Museum of the Mountain Man p. 93
- Museum of the Plains p. 87
- Northeastern Nevada Museum p. 86
- O.K. Corral p. 15
- Olaf Wieghorst Museum p. 73
- Panhandle-Plains Historical Museum p. 91
- Pawnee Bill Ranch & Museum p. 100
- Phippen Museum p. 2
- Red River Valley Museum p. 94
- Santa Ynez Valley Historical Museum p. 87
- Sharlot Hall Museum p. 2
- Smoki Museum of American Art and Culture p. 2
- Stuhr Museum of the Prairie Pioneer p. 86
- Superstition Mountain Museum p. 93
- Texas Ranger Hall of Fame & Museum p. 97
- The Brinton Memorial & Museum p. 97
- The Bryan Museum p. 107
- Washington on the Brazos State Park Assoc. p. 93
- Wells Fargo History Museums p. 94
- West Texas Trail Museum p. 94
- Western Spirit: Scottsdale's Museum of the West p. 103
- White River Museum p. 93
- Wind River Hotel and Casino p. 11
- Yuma Territorial Prison Museum p. 94
- Stark Museum of Art p. 101

PRESERVATION

- Fay Ranches p. IBC
- Texas Rangers Heritage Center p. 111
- Washington on the Brazos State Park Assoc. p. 93

TOURISM

- Albany, Wyoming p. 84
- Antonito, CO p. 60
- Bandera, TX p. 96
- Big Bend National Park, TX p. 61
- Chama, NM p. 97
- Cody, WY p. 57
- Deming, NM p. 100
- Dodge City, KS p. 61
- Elko, NV p. 99
- Kearney, NE p. 77
- Llano, TX p. 20
- Ogallala, NE p. 72
- Ottawa, KS p. 56
- Prescott, AZ p. 2
- Scotts Bluff/Gering, NE p. 64
- Terlingua, TX p. 61
- The Dalles, OR p. 63

OTHER

- Bob Boze Bell O.K. Corral Complete Book Set p. 108-109
- TW Classic Fire Arms Collectors Set p. 65
- TW Best Photos of the Old West Collector's Set p. 71



CLASSIC FIREARMS COLLECTOR SET

\$39.95 *plus S&H

A \$46 value

Order yours today! More great sets available online.



Store.TrueWestMagazine.com

888-687-1881

A Legendary Life



A chronicle of the myths of the mountain man, a biography of a Western engineer, a burg of sinners and saints, a first-class tourism company, and a town too tough to die.

The mythic history of the American West is veiled in the mysterious mists of time like the fog-shrouded British legends of King Arthur, Beowulf and Strong Bow. The mountain men, fur trappers, trailblazers and voyageurs who roamed, rode, paddled, traded and fought across the mountains and plains of North America in the 18th and 19th centuries are equally equated with the English knights of yore and the Hells Angels of the present. In *Hugh Glass: Grizzly Survivor* (South Dakota Historical Society Press, \$14.95) James McLaird, a Dakota Wesleyan University professor emeritus of history, provides a comprehensive analysis of the well-chronicled life of legendary Western trapper Hugh Glass.

Part biography, part historiography, part literary criticism, McLaird's march into the depths of the archives, articles, nonfiction, fiction, film and fantasy must have seemed as daunting as Glass's 1823 fight with the grizzly and subsequent trek of survival.

Academy Award-winner Leo DeCaprio's interpretation of Glass in *The Revenant* (20th Century Fox, 2015) looms large over McLaird's biography—as do articles and exposés on the historical veracity of the cinematic epic and other interpretations, including Frederick Manfred's novel *Lord Grizzly*, a top favorite of critics. The South Dakota biographer's depiction of Hugh Glass provides an extremely accessible, succinct interpretation of the fur trapper's

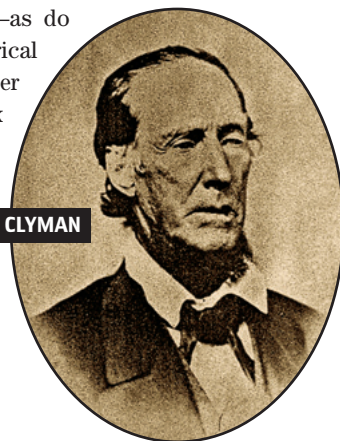

James D. McLaird's unique biography *Hugh Glass: Grizzly Survivor* interweaves the historical record legend, lore, primary and secondary sources and edited diaries including trapper James Clyman's reminiscences.

— COURTESY LIBRARY OF CONGRESS —

In *Hugh Glass: Grizzly Survivor*, author James D. McLaird provides the reader with a comprehensive analysis of every available historical and fictional source including the 1938 illustration of the giant bear's mauling of the legendary mountain man.

— COURTESY FEDERAL WRITERS' PROJECT, A SOUTH DAKOTA GUIDE —

life—real and literary. As McLaird states succinctly in the introduction: “Because our understanding of Hugh Glass arises only through those who have shaped his legend, this biography will present the words of these storytellers and other important sources exactly as they first appeared.”

The strength of McLaird's biography is evident on every page: the author is extremely confident in his research and provides the reader with a fact-filled, synthesis that is fun to read, inspires the inquirer with a path to further research and reading, and most importantly, builds a strong case for exactly what we know, what we don't know, and what we presume we know about the grizzly-scarred mountain man. Glass's epic fight with the bear, betrayal by friends and death-defying trek across the wilderness to civilization has been a favorite of modern novelists and filmmakers, literary chroniclers, historians, and myth-makers since the first article was published in Philadelphia's *The Port Folio* in 1825. As a historian—and a fan of mountain man history—Winfred Blevins *Give Your Heart to the Hawks* is my personal favorite—I feel McLaird's well-written bio-historiography treads lightly on those who repeated the legends, while he elevates those who challenged the lore with facts and evidence. In doing so, the reader will return to McLaird's conclusions again and again as an evergreen resource for chroniclers of the fur trade.

McLaird's conclusions about Glass are substantiated with an extremely useful bibliography and excellent, highly detailed endnotes. Anyone proposing to write an



article on the history of the fur trade in the Rocky Mountain West will want this book within arm's reach, as the volume stands alone in 2016 as the primary, most comprehensive synthesis of the published literature on Glass and his contemporaries.

McLaird, who also authored *Wild Bill Hickok and Calamity Jane: Deadwood Legends* and *Calamity Jane: The Woman and the Legend*, has provided authors, researchers, aficionados and novelists with a new historical baseline on the mountain man and the grizzly that propelled him into the history books and the mythic mists of time.

—Stuart Rosebrook



Jeb Rosebrook
Tallgrass Writing Workshop

The 31st Annual **Tallgrass Writing Workshop**, hosted by the Center for Great Plains Studies at Emporia State University, should be on everyone's early summer writing workshop calendars. *True West* contributor and author Professor **Max McCoy** directs the workshop, held this year on June 11-12. The center's director is Great Plains folklorist-historian **Jim Hoy**, who with the late **Don Goldsmith**, founded the Western Writers of America-sanctioned event.

The two-day writing retreat is a great precursor to the annual **WWA Conference**, which was June 22-26, in Cheyenne, Wyoming. Author-screenwriter **Jeb Rosebrook** was the Tallgrass keynote speaker, his address entitled “The Luck of the Draw: A Writer's Life.” Author-musician and former WWA president, **W.C. Jameson**, taught a class on songwriting and entertained the workshop with a wonderful evening of original songs. Workshops were conducted by marketing specialist **Patsy Terrell**, former FBI agent and author **Mark Bouton**, Emporia State English Professors **Kevin Rabas** and **Rachelle M. Smith** and, for the second year, *True West* Senior Editor **Stuart Rosebrook**.

Recent books by the participants include Bouton's *The Sacrifice*; Jameson's *Pat Garrett: The Man Behind the Badge*; McCoy's *Giving Up the Ghost*; Rabas's *Songs for My Father*; Jeb Rosebrook's *Forever More and Saturday*; and Stuart Rosebrook's *At Work in Arizona*.

If you'd like to attend in 2017, contact the Center at: Emporia.edu/cgps.

—Stuart Rosebrook



A WESTERN LIFE WELL LIVED

Charles Stone is best known as an infamously treated scapegoat. In his concise and well-sourced biography, Blaine Lamb—author of *The Extraordinary Life of Charles Pomeroy Stone: Soldier, Surveyor, Pasha, Engineer* (Westholme Publishing, \$29.95)—takes Stone from West Point, through his contributions in Winfield Scott’s invasion of Mexico, to his self-inflicted financial disasters in California and Sonora, his stellar

service organizing Washington’s defenses at the outset of the Civil War, his loose leadership at Ball’s Bluff that led to his unconstitutional imprisonment without any charges filed, and on to his 13-year service to the ruling khedive of Egypt, and his construction of the base and pedestal of the Statue of Liberty.

—Paul Cool, author of *Salt Wars: Insurgency on the Rio Grande*

Blaine Lamb’s biography *The Extraordinary Life of Charles Pomeroy Stone* chronicles the life of the

inimitable military engineer, including his lifelong friendship with fellow West Pointer President Ulysses S. Grant (center in sun helmet), who visited Karnak, Egypt, in 1878.

—COURTESY LIBRARY OF CONGRESS —

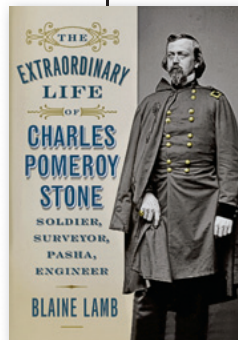

ANGELS AND THE BAD MEN—AND WOMEN

Deadwood’s story, as revealed in *Deadwood Saints and Sinners* (Farcountry Press, \$14.95) by Jerry Bryant and Barbara Fifer, is more than Calamity Jane’s antics and Wild Bill Hickok’s assassination. The book covers topics including Deadwood’s first telephones, and the first locomotive hauled in by oxen.

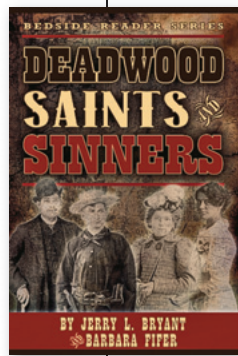



NAVY ARMS



A LIGHTNING LIKE NO OTHER, ONLY FROM NAVY ARMS



Over the past decade numerous companies have tried to make a replica of this famed pump-action rifle originally made by Colt. Working with Davide Pedersoli of Italy, famed for their high-quality replica firearms, the Navy Arms Lightning features stocks made from hand-selected, fully checkered Grade 1 American Walnut. The receiver and furniture are bone charcoal color case-hardened in the United States, accented with nitre blued screws and a high-polish blued full octagonal barrel. A unique coil-spring extraction system that ensures fast, high ejection of spent cartridges, unlike other maker’s systems. Semi-buckhorn rear and gold-bead dovetail front sights. The upper tang is drilled and tapped for the Marble Arms peep tang sight. Available in 20” and 24” bbl lengths and in both .45 Colt and .357 Magnum. Only Navy Arms, the company that founded the replica firearms industry, has produced a Lightning combining perfection in functioning and superior fit & finish.

54 Dupont Rd., Martinsburg, WV 25404 ph - (304) 274-0004 info@navyarms.com



A star of *Deadwood Saints and Sinners* is Madame Mollie Johnson, known as the Queen of the Blondes, equally dedicated to her blond-haired girls (including the above unknown girl from "her harem"), her customers, and the community.

— COURTESY JERRY L. BRYANT PRIVATE COLLECTION —

It covers a wide range of characters including Old Frenchy the Bottle Fiend, who amassed thousands of bottles and cigar butts; the black political activist General



The Fred Harvey Company's ability to adapt and modernize its Southwestern hotels, restaurants and passenger tours through the decades is well illustrated in *Over the Edge*, as the meeting of Harveycars, drivers, cowboys, packers and tourists is picturesquely juxtaposed with the Grand Canyon in the background.

— COURTESY FRED HARVEY COMPANY ASSOCIATION FILES, BILLIE JANE BIGLEY LIBRARY AND ARCHIVES, PHOENIX, ARIZONA —

Samuel Fields, who on foot raced a horse and won; and Minnie Callison, *Deadwood's* first school marm who was murdered in her sleep. Jerry Bryant, a good friend and meticulous historian, always told the unvarnished truth and this book bears that trait.

—Bill Markley, author of *Deadwood Dead Men*

FRED HARVEY DAYS

It's easy to forget that much of today's popular image of the Southwest is testimony to the marketing and advertising genius of the Fred Harvey Company and the Atchison, Topeka and Santa Fe Railroad. In their lushly illustrated *Over the Edge: Fred Harvey at*

Favorite Books

FROM AUTHOR CHRIS ENSS

VISIT WWW.CHRIENSS.COM FOR MORE INFORMATION ABOUT THESE AND OTHER TITLES

TwoDot
An Imprint of Globe Pequot
www.rowman.com
Distributed to eTrade by National Book Network
800-426-5420 | www.nbnbooks.com



TOM REPPERT

Award Winning Author of Two Epic Novels of The Old West



The Captured Girl, a sweeping saga of war, love and tragedy during the Great Sioux War. Four years a captive, Morgan O'Connor now lives in a white world that shuns her and her Cheyenne son, while young cavalry Lieutenant Will Raines must adapt to the crucible of combat or die.

The Far Journey, a vivid, time-slip novel of survival on the Oregon Trail. Young Paula Masters finds herself thrust back in time to the deadly, alien world of virulent disease, buffalo stampedes, and wild Indians. Rich in dramatic action and authentic in everyday details.

~ Available at Amazon.com ~



TEXAS AUTHOR RECOUNTS BEST IN RANGER HISTORY

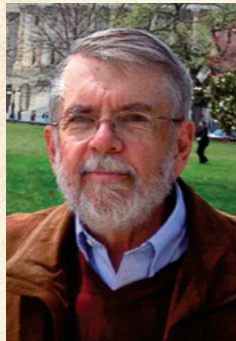

Third-generation journalist **Mike Cox** was born in Amarillo and raised in Austin. After 20 years of working for newspapers, he went to work for the Texas Department of Public Safety for 15 years and then the state highway department and the Texas Parks and Wildlife Department before retiring in 2015. A member of the Texas Institute of Letters, Cox has written 28 nonfiction books and hundreds of articles, including his highly rated two-volume Ranger history, *Wearing the Cinco Peso: The Texas Rangers 1821-1900* and *Time of the Rangers: Texas Rangers 1900 to Present* (New York: Thomas Doherty Books). He has three

more books under contract and is the editor of the *Wild West History Association Journal*. He now lives in the Hill Country community of Wimberley.

Cox says the narrowing of a list of the best Ranger books down to just five is like the old "one ranger, one riot legend"—easy to say, hard to do. So, here are his top six:

❶ ***Six Years with the Texas Rangers, 1875-1881*** (James B. Gillett, Andesite Press): The best 19th-century Ranger memoir is James B. Gillett's. First published in 1921, it remains in print for good reason. It is highly readable and full of insight into the life and duties of the Frontier Battalion-era ranger.

❷ ***Trails and Trials of a Texas Ranger*** (W.W. Sterling, University of Oklahoma Press): The best early 20th-century memoir is Bill Sterling's. Privately published in 1957 shortly before the old ranger's death, this book was out of print for a while, but the University of Oklahoma Press brought it back to life in 1969 and it remains in print today.

❸ ***One Ranger: A Memoir*** (Joaquin Jackson, University of Texas Press): The best late-20th-century memoir, a fine inside look at the modern-day Texas Ranger's life is the late Ranger Joaquin Jackson's. Published in 2005, it remains that publisher's top-selling book to date. Texas author David Marion Wilkinson worked with Jackson in writing the book.

❹ ***Yours to Command: The Life and Legend of Texas Ranger Captain Bill McDonald*** (Harold J. Weiss, University of North Texas Press) and ***Texas Ranger John B. Jones*** (Rick Miller, University North Texas Press): The best 19th-century ranger biographies are a draw. Captain Bill, as he was known, contributed heavily to the Ranger legend and Weiss does a great job sorting out truth and fiction in this work. Jones served as the first major of the Frontier Battalion when it was created in 1874 and rose to the position of state adjutant general before his early death in 1881.

❺ ***Texas Ranger: The Epic Life of Frank Hamer, the Man Who Killed Bonnie and Clyde*** (John Boessenecker, Thomas Dunne Books): Boessenecker's new book is the best 20th-century Ranger biography. Hamer served as a Ranger from 1906 through the early 1930s. Boessenecker successfully argues that the publicity Hamer garnered for the Rangers in the killing of Bonnie Parker and Clyde Barrow helped save the Rangers from the legislative axe.



Mysterious murders, a border town flush with money, a corrupt Mayor, a showdown at High Noon on Main Street ending in another murder, and a beautiful woman's thirst for revenge.

A **Contemporary Western** that challenges "The Big Gun," Bakoda Pak, when he comes to town.

Big Lizard now Available in Paperback for \$14.95, shipping included in the Continental US

Order Now From Grandview Press at havamystery.com

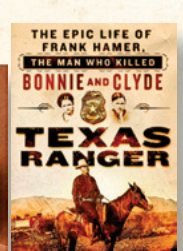
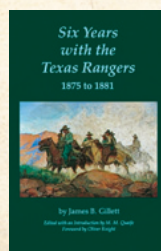

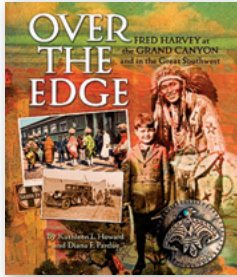

the Grand Canyon and the Great Southwest (Rio Nuevo Publishers, \$22), Heard Museum research associate Kathleen L. Howard and collections curator Diana F. Pardue describe how the railroad and its legendary concessionaire lured tourists by encouraging Native crafts and fashioning a “Southwestern style” that appealed to adventurous Easterners. *Over the Edge* is a splendid introduction to both the Heard Museum’s extensive collections and the rich legacy of the Fred Harvey Company at the Grand Canyon and throughout the Southwest.

—Bruce J. Dinges, editor of
Journal of Arizona History

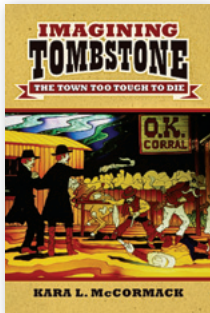

THE TOMBSTONE MYSTIQUE

What’s it mean to market authenticity? That’s the question Kara McCormack, a postdoctoral teaching fellow in the Thinking Matters Program at Stanford University, asks in relation to the town where the most famous gunfight in the history of the Old West took place. In *Imagining Tombstone: The Town Too Tough to Die* (University Press of Kansas, \$27.95) she examines the question from the perspective of historians, preservationists, filmmakers, community boosters and tourists. McCormack’s strength is her ability to bring these disparate elements into a comprehensive profile of a town which is, for much of the world, an enduring symbol of the mythic west.

—Max McCoy, author of
Giving up the Ghost

Best Photos of the Old West Collector’s Set

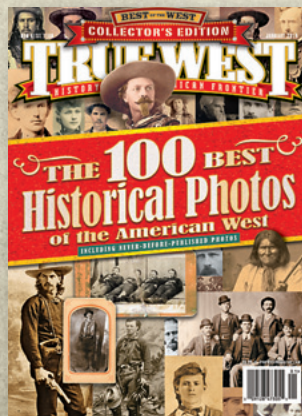
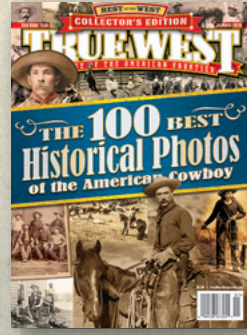
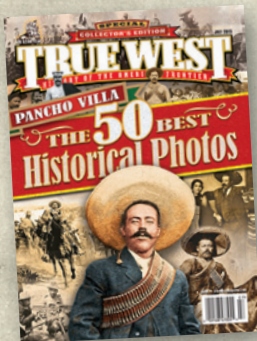

Over 500 Old West historical photos from our *True West* collections.

\$39.95 S&H

A \$56 Value

To find more great deals, visit our online store. *True West* offers many exciting sets to choose from. Add to your personal collection today!



Store. TrueWestMagazine.com

888-687-1881

Let ^{THE} Trail Take You
TO **OGALLALA, NEBRASKA**



Petrified Wood & Art Gallery

Boot Hill Cowboy Cemetery

Front Street Revue – Old West Show

Mansion on the Hill Museum
(circa 1887)

Lake McConaughy

Call 800-658-4390
for a free Visitors Packet.

OgallalaTrails.com

Sponsored by the Keith County
Visitors Committee



TEXAS GUN COLLECTORS ASSOCIATION
cordially invites you to join us at our
**ANNUAL ARMS
COLLECTORS SHOW**

October 14-16, 2016

at the Texas Cowboy Hall of Fame
Historic Stockyards District
128 East Exchange Avenue
Fort Worth, TX 76164

**The finest antique, classic
and collectible firearms will be
on sale and on display.**

**ALL ARE WELCOME.
BUY, SELL, TRADE!**

Come Share the Fort Worth Experience!

Contact: Sean Walsh, Show Chairman
210-391-6860
aimin2@yahoo.com

www.tgca.org

Joaquin Jackson

1935-2016

BY MIKE COX

The caller was a TV producer with BBC in London.

“We are doing a documentary on the Colt revolver, the famous Texas Ranger Jack Hays and the Indian fight at Enchanted Rock,” he informed me in crisp British-speak. “We want to land a helicopter on Enchanted Rock and film a modern Ranger getting out of it. Can you arrange that?”

As spokesman for the Texas Department of Public Safety, which includes the Rangers, I knew the state could not lend one of its aircraft for commercial purposes. But the agency certainly could furnish a real Ranger. I called Capt. Jack Dean, commander of Co. D, and asked if he could make a Ranger available for the shoot.

“I’ll have Joaquin Jackson call you,” he said without hesitation.

That was in 1986, the beginning of a friendship that lasted nearly 30 years. Perhaps Texas’ best-known late-20th century Ranger, Jackson died in Alpine, Texas, on June 15. He was the last of the Rangers who had served under tough-as-boots Capt. A.Y. Allee, who ruled South Texas with an iron hand in the 1950s through late ’60s.

The BBC crew chartered a private helicopter and got their footage of the tall, lanky Jackson in his trademark starched brown shirt, tight dark Wranglers and big white hat climbing out of the chopper and showing the well-worn Colt .45 revolver he still carried on occasion.

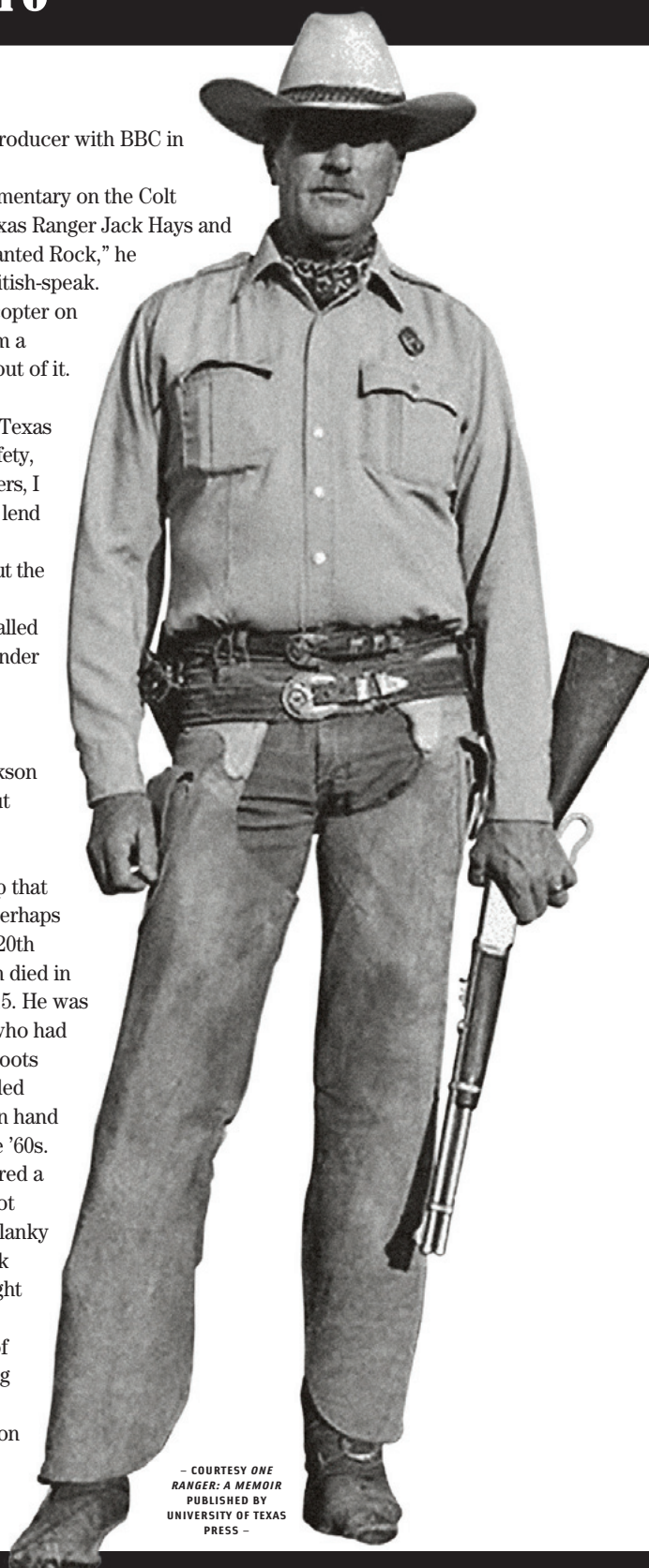

— COURTESY ONE
RANGER: A MEMOIR
PUBLISHED BY
UNIVERSITY OF TEXAS
PRESS —

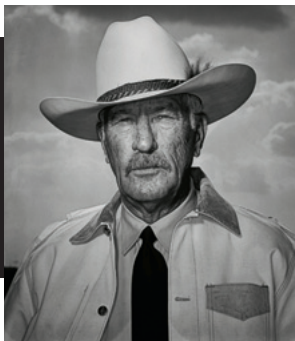

Joaquin Jackson

- PHOTOGRAPH BY DAN WINTERS ©2007 -

Jackson served as a Ranger from 1966 until 1993. He and his late wife, Shirley, were credited with launching the singing career of Johnny Rodriguez, who Jackson had arrested for goat theft. In 1988 the Ranger made national news by tracking down three Mexican teenagers who had fired on American rafters in a canyon along the Rio Grande in the Big Bend, killing one of them. Shortly after he retired, *Texas Monthly* ran a cover photo of Jackson holding the sawed-off Winchester .30-30 he always toted. He went on to write two best-selling memoirs published by the University of Texas Press (*One Ranger* and *One Ranger Returns*), appeared in five movies—including *The Good Ole Boys* (with actor Tommy Lee Jones) and *Streets of Laredo*—a TV mini-series based on a Larry McMurtry novel, and served on the board of the National Rifle Association.

In 1991, Jackson and I searched for a remote box canyon near the border where in 1915 Mexican bandits had ambushed and killed Ranger Eugene B. Hulen and ex-Ranger Joe Sitters. As we left Presidio in a four-wheel-drive vehicle, Jackson pointed to his favorite Winchester in the backseat.

"There ain't no 911 where we're going," he told me. "Use that if you need to."

It was nice to know where that lever-gun lay, just in case, but with Joaquin Jackson as my guide, I felt pretty darned safe. Happy trails, mi amigo.



Mike Cox, who worked for the Texas Department of Public Safety for 15 years, is the author of *The Texas Rangers: Wearing the Cinco Peso, 1821-1900* and *The Time of the Rangers: The Texas Rangers, 1900 to Present*.

SOUTHERN SON

THE SAGA OF DOC HOLLIDAY

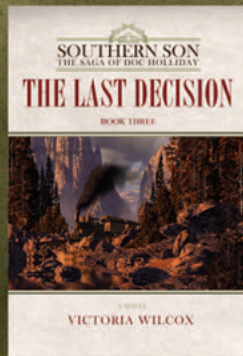
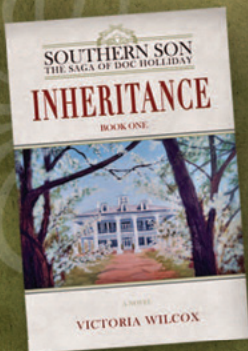

Now in paperback!

The Epic Story of the West's Most Famous Southern Gentleman

"Here, Doc is alive and his world real—wonderfully so." — *Biographer Dr. Gary Roberts*

"A must read for fans of the Old West" — *Kirkus Reviews*

2016 Winner of True West's Best Historical Western Novel

A trilogy of historical novels available from Amazon, Barnes & Noble, and wherever books are sold

Visit the world of Doc Holliday at www.VictoriaWilcoxBooks.com

OLAF WIEGHORST MUSEUM & WESTERN HERITAGE CENTER



Olaf Wieghorst "Partners" 1976 Oil on Canvas

Original Wieghorst Art in Main Gallery • Wieghorst Prints in the Gift Shop

Historic Home of Olaf and Mae Wieghorst set in our acclaimed Cactus Garden

Tours of Museum and Olaf's House available: Call for Information

Cactus Garden and Museum available for events; weddings, dinners, receptions

Call 619.590.3431 for information

131 Rea Avenue – near Main and Magnolia • El Cajon, California – 619-590-3431

Open Tuesday – Friday 10am – 3pm • Last Saturday of Month 11am – 4 pm

To see all our events visit, www.wieghorstmuseum.org

~Friend the Museum on Facebook~

LEO W. BANKS

Crossroads of the West

A heartland oasis, Kearney, Nebraska, celebrates its Western heritage year round.



The Union Pacific Railroad connected Kearney to the nation, which brought the citizens of Buffalo County a 1908 visit from the circus.

— COURTESY NEBRASKA STATE HISTORICAL SOCIETY, SOLOMON D. BUTCHER, NBHIPS, 13274 —

Fort Kearny, the first U.S. Army post on the Oregon Trail, was a busy place after its founding in 1848. During one 18-month period following the 1849 Gold Rush, some 30,000 pioneers passed through, headed for California, Utah and Oregon.

Several westbound trails met there, as did two railroads, and the fort served as a

stage station, an outfitting depot for Indian campaigns, and home for Pony Express riders.

The town of Kearney today is a sweet, close-knit community of 30,000 on the Platte River. Often called the Midway City, it's in the center of the United States, equidistant between the Atlantic and Pacific oceans, and transportation is still a draw.



The Archway museum near Kearney features interactive exhibits that poignantly recount the trials and tribulations of the emigrants who dreamed of a new beginning in Utah, Oregon and California.

— COURTESY NEBRASKA TOURISM —



Exhibits at Fort Kearny State Historical Park's museum celebrate the people of the plains, from past to present, including the clash between the Plains Tribes and the American military.

— COURTESY NEBRASKA TOURISM —

Kearney's most unique attraction is The Archway, a 79,000-square-foot Disney-style center that stretches 310 feet across Interstate 80. The site, which opened in 2000, uses exhibits, videos, photographs and dioramas to highlight 170 years of transportation history, from Mormon handcarts on dusty trails to Cadillacs on the interstate. Re-enactors demonstrate how Pony Express riders changed horses and tell true and dramatic stories about the hardships of frontier travel. Nothing about the arch is small, and that includes the ten-foot fiberglass

bison statue, commissioned by CNN's Ted Turner, standing outside. The Archway appeared in the 2002 movie *About Schmidt* starring Jack Nicholson.

For a ground view of the area's rich military history, stop at Fort Kearny State Historical Park, three miles east of town. The post was named for Stephen Watts Kearny, the general who wrested California from Mexico in 1847.

Note the spelling discrepancy between the general and the town. The explanation speaks to Kearney's easygoing charm: The post office goofed and it was too troublesome to correct.

The fort has an interpretive center, and the stockade, parade grounds and blacksmith shop have been rebuilt. Living history demonstrations take place during summer holidays.

For nature-lovers, the Fort Kearny Hike-Bike Trail makes a fun outing. The easy jaunt crosses a wooden railroad bridge over the Platte River and popular sites for dawn and dusk viewing of migrating sandhill cranes.

In-town sites include downtown Kearney, featuring restaurants, bars, two microbreweries, antique shops and the restored World Theater, which opened as a vaudeville venue in 1920. The city plants flowers at intersections

during summer and fall, and visitors enjoy a quirky area called The Bricks, where the streets are actually paved in brick.



Stroll through Cliff Hillegass Sculpture Garden before touring the Museum of Nebraska Art in Kearney, housed in the 1911 post office building, to view one of the nation's best Great Plains art collections featuring works by George Catlin and John James Audubon.

— COURTESY J. NABB/NEBRASKA TOURISM —

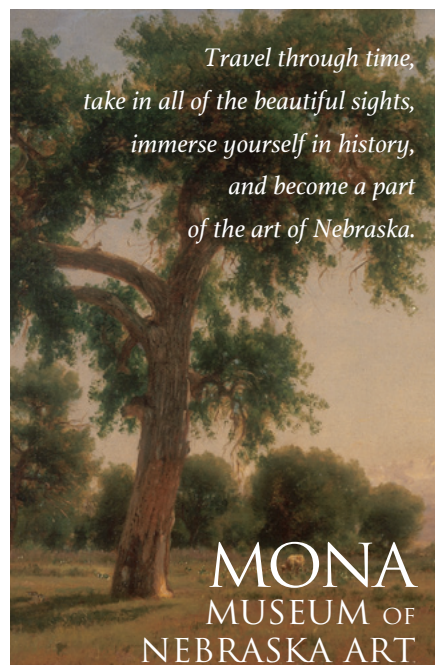

Travel through time,
take in all of the beautiful sights,
immerse yourself in history,
and become a part
of the art of Nebraska.

MONA MUSEUM OF NEBRASKA ART

2401 Central Avenue • Kearney, Nebraska
(308) 865-8559 • mona.unk.edu
Open: Tue.-Sat. 11 a.m.-5 p.m., Sun. 1-5 p.m.
Closed Mon & major holidays.
Admission: FREE, open to the public.

(detail): Thomas Worthington Whittredge, *Cattle Grazing Along the Platte*, oil on canvas. Museum Purchase made possible by Cliffs Charitable Foundation, Museum of Nebraska Art Collection



G.W. Frank Museum of History and Culture

Museum Hours:
Tues.- Fri., 1-5pm & Sat.-Sun., 2-5pm
Closed Mondays and major holidays

Admission: Free
Donations appreciated.

Reservations are required for all private events; weddings, receptions, etc., and group tours outside of our public hours.

Contact Us:
FrankMuseum@unk.edu
or call (308) 865-8284

Follow us on Facebook!

NEBRASKA'S PREMIERE NATIVE AMERICAN JEWELRY STORE

Genuine Turquoise

David Rosales Inlay

Black Beauty Jewelry

STAGECOACH
310 3RD AVE KEARNEY, NE
STAGECOACHGIFTS.BIZ
308-234-3313

Harold Warp PIONEER VILLAGE



PONY EXPRESS STATION

SEE HOW AMERICA GREW

Over 50,000 historic items displayed in the order of their development in 26 buildings!

HIGHLIGHTS INCLUDE

- Buggies
- Wagons
- Harness
- Guns
- Sod House
- Indian Stockade
- Pioneer Depot
- Livery Barn
- Over 350 Autos
- 100 Tractors
- 7 Generations of Kitchens
- Buffalo Bill's Saddle
- 20 Historic Airplanes



Rated by True West 3 years running as:
Best Pioneer History Collection.

Adjoining
MOTEL & CAMPGROUND
(800) 445-4447

138 E Hwy 6, Minden NE 68959

www.pioneervillage.org



Kearney's 47th Annual Audubon Crane Festival will be held March 16-19, 2017, in celebration of the migration of the half-million sandhill cranes who nest along the Platte River every spring.

- COURTESY KEARNEY CVB -

The "Nebraska Now" exhibit highlights contemporary masters who continue to tell the state's dramatic story through art.

"We have two parades during the year, murals, a barbecue on the bricks competition, and a Cruise Nite festival featuring classic cars," says Sarah Focke of the visitors bureau. "The city works hard to keep downtown vibrant."

Don't miss the Museum of Nebraska Art, housed in a post office building erected in 1911 and listed on the National Register of Historic Places. Its collection comprises more than 5,000 works by masters including George Catlin, who traveled to the West in the 1830s to paint Plains Indians.

The museum also holds Thomas Hart Benton's original illustrations of Francis Parkman's 1847 book on the Oregon Trail, and wildlife art by John James Audubon.

A museum of a different kind attracts car-lovers from around the country to its 50,000-square-foot space in the Cabela's store off Highway 30. The Classic Car Museum boasts 200 rare and historic vehicles in its popular collection, including a 1938 Rolls-Royce Wraith limousine and a 1958 Studebaker Golden Hawk.

Remember the muscle cars of the '60s like the GTO? Remember giant tailfins and the iconic Thunderbird? The museum has them all, with interactive displays that educate visitors on the role the automobile has played in our history and culture. ❏

Leo W. Banks is an award-winning writer based in Tucson. He has written several books of history for *Arizona Highways*.

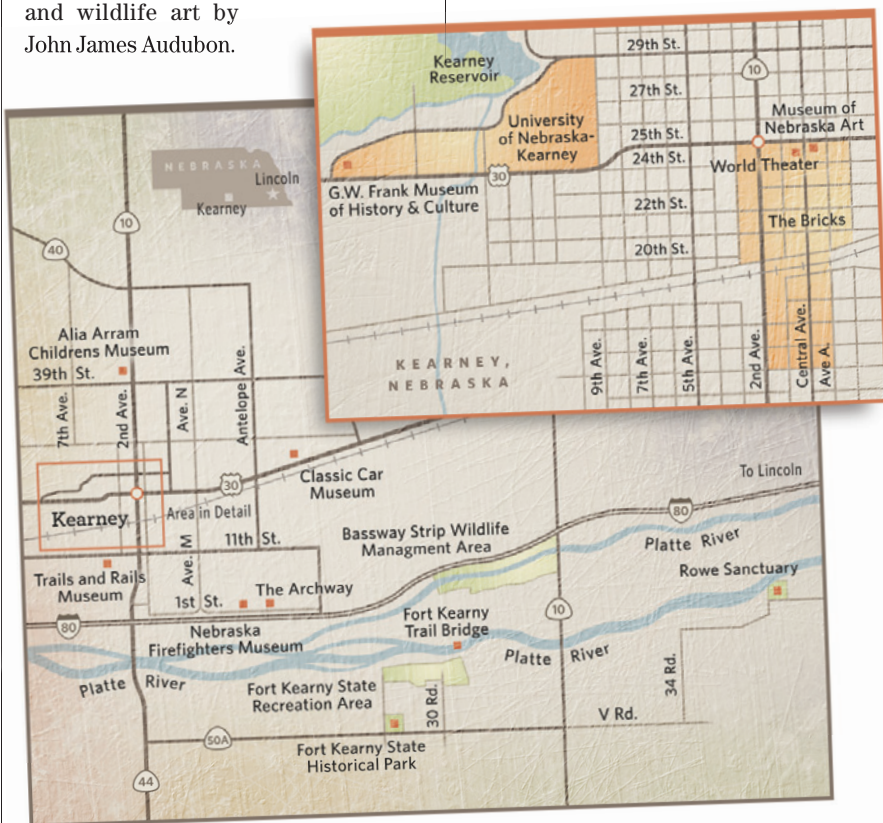

WHERE HISTORY MEETS THE HIGHWAY



COURTESY KEARNEY CVB

Start planning your trip at the Kearney Visitors Bureau in the G.W. Frank Museum (above) at 1007 Second Avenue, conveniently located off Interstate 80 at Exit 272.

VisitKearney.org

G.W. Frank Museum of History & Culture

Architect George William Frank Jr. designed the house and completed it in 1889, the first west of the Missouri River to be wired for electricity. Made of Colorado red sandstone mined from Wyoming, it features tiles imported from Holland, beautiful carved oak woodwork and a Louis Comfort Tiffany stained-glass window. On the campus of the University of Nebraska-Kearney. Tours available.

UNK.edu

The Nebraska Firefighters Museum & Education Center

See vintage firetrucks, historic photos, a memorial to fallen firefighters and an interactive display about 9/11.

NebraskaFirefightersMuseum.org

Rowe Sanctuary

Twenty miles outside Kearney, Rowe Sanctuary offers guided tours to blinds that are strategically placed along the Platte River where you can see a half million sandhill cranes roost during their annual spring migration. Their loud, rattling bugle calls make a thrilling sound that can be heard almost three miles away. Call for information or schedule your tour today.

Rowe.Audubon.org

Buffalo County Historical Society's Trails & Rails Museum

Tour guides lead visitors around the grounds to see a 1903 Baldwin steam engine, a log cabin from the 1860s, and the Loup River Freighters Hotel, built in 1884. The Boyd Ranch House is the first frame house in Buffalo County. Blacksmithing demonstrations. The museum is located on an original portion of the Mormon Trail.

BCHS.org

KEARNEY

»—————»
MAKE THE MOST OF YOUR STAY



THE ARCHWAY



Transport back in time and travel the trails, rails and highways that built America!



CLASSIC CAR COLLECTION



Come check out the 160+ beautifully restored historic automobiles from the early 1900's to the modern era!



visitors bureau

visitkearney.org

Check our website for a list of current events!

EXPERIENCE. EXPLORE. ENJOY.



Boot Hill Museum is the premier heritage destination in Dodge City, Kansas. A traditional longhorn cattle drive through town and past the museum's Front Street is a highlight of the 12-day Dodge City Days celebration, held every year at the end of July.



**TOP
10
MUSEUMS
OF THE WEST
2016**

THE EDITORS / WRITTEN
BY CANDY MOULTON

GO WEST!

Stories of Western heritage engage visitors of today...and the future.

Museums across the West continue to embrace Old West stories with exhibits on John C. Fremont, Liver Eatin' Johnston, cattle trails and the Buffalo soldiers, but as they reach out to newer audiences, they are expanding their storylines. In our "Top Ten Museums of 2016" you might have a chance to learn about and view work of Old West artists, guns from the Western television era or even hear the histories of World War II veterans.

The trend we are seeing as we cross the West visiting museums, is the desire to not only show the artifacts that are important to a local place—from prehistoric tools to 20th-century clothing—but to engage visitors through use of better films, more interactive exhibits and stronger programs, particularly those aimed at younger visitors. Now more than ever it is time to take the family to the museum.

We've looked far and wide and have selected a top ten list of museums, but we can't stop there and have many more museums we highly recommend you take the time to explore.

Candy Moulton lives near Encampment, Wyoming, and has traveled the United States extensively, always making time for a visit to a local museum.



BOOT HILL MUSEUM

Dodge City, KS

From the opportunity to play a game of cards with Doc Holliday at a life-sized sculpture in front of the Boot Hill Museum, to the rumbling experience of a buffalo hunt, a visit to this museum is an immersion in the Old West. The museum presents shows in the Long Branch Saloon, focusing on that famous Dodge City bunch: Miss Kitty, Matt Dillon and the cast of *Gunsmoke*.

Boothill.org



Dodge City's Boot Hill Museum holds entertaining gunfights along Front Street twice a day throughout the summer, while inside exhibitions on gambling, guns and American Indian history provide valuable insights into life on the Kansas frontier.

— PHOTOS COURTESY BOOT HILL MUSEUM —



The Panhandle-Plains History Museum in Canyon, Texas, houses one of the most significant Great Plains art collections, including George Catlin's *Buffalo Chase, A Surround by Hidatsa*.

— COURTESY PANHANDLE-PLAINS HISTORY MUSEUM —

2

PANHANDLE-PLAINS HISTORICAL MUSEUM

Amarillo, TX

Watch for the Western Illustrators Gallery, being installed this fall, which will feature artists whose work is part of the permanent collection of Panhandle-Plains Historical Museum. Among the artists included in the exhibit are W. Herbert Dunton, Frank Tenney Johnson, Edward Borein, Matt Clark, H. D. Bugbee, Will Crawford, Herbert Morton Stoops, Arthur Mitchell, N. C. Wyeth, Philip R. Goodwin and Frank B. Hoffman.

PanhandlePlains.org

CODY FIREARMS MUSEUM

Cody, WY

See a Hawken rifle that once belonged to John "Liver Eatin'" Johnston and Colt Single Actions used in *Bonanza* and *Gunsmoke* among the hundreds of firearms on display. A new exhibit centers on quick-draw competitor Bob Munden. The museum includes the Winchester Arms Collection, but also has Sharps, Henry, Hawken, and Spencer rifles, along with the John Moses Browning firearms collection.

CenterOfTheWest.org

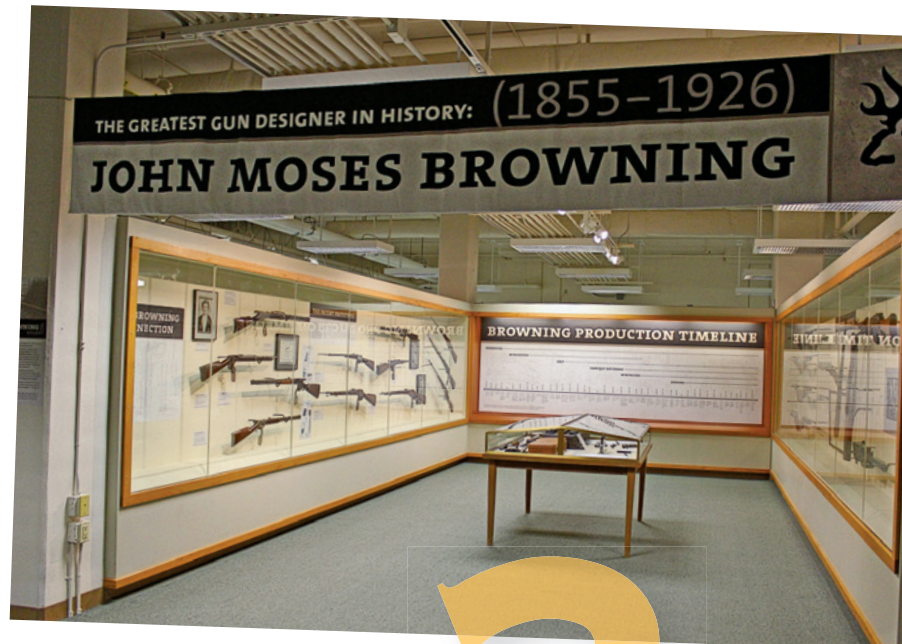

The Cody Firearms Museum, one of five museums at the Buffalo Bill Center of the West in Cody, Wyoming, is considered one of the finest arms museums in the world and includes a special display dedicated to Utah firearms inventor, John Moses Browning.

— COURTESY BUFFALO BILL CENTER OF THE WEST —

3

**TOP
10
MUSEUMS
OF THE WEST
2016**

The Buffalo Soldiers National Museum in Houston, Texas, is the nation's headquarters for the sesquicentennial celebration of the famed units created after the Civil War to serve in the Indian Wars.

— COURTESY BUFFALO SOLDIERS NATIONAL MUSEUM —



4

BUFFALO SOLDIERS NATIONAL MUSEUM

Houston, TX

This museum has a broad mission to preserve the legacy of black American soldiers beginning with those who fought in the Revolutionary War, and continuing through the soldiers of the Indian Wars and into the 20th century. Each Saturday the “Day in the Life of a Buffalo Soldier” program is presented and the museum also takes presentations into schools. This July the museum sponsored the 15th Anniversary Reunion of the Buffalo Soldiers.

BuffaloSoldierMuseum.com

5

DAYS OF '76 MUSEUM

Deadwood, SD

Here you'll see outstanding artifacts, including a unique carriage and horse-drawn vehicle collection, and public programs on topics ranging from Calamity Jane and other women of the Old West to

Lakota traditions and caring for your personal heirlooms. We like that the museum holds history camps for children during which they learn about the characters in Deadwood's past.

DeadwoodHistory.com



The Days of '76 Museum in Deadwood, South Dakota, provides visitors an interactive introduction to the history of the wild mountain mining town, including its signature collection of horse-drawn vehicles, and one of the state's oldest heritage events.

— COURTESY DAYS OF '76 MUSEUM —

LIVE THE LEGEND



OPEN YEAR ROUND

World's Largest Collection
of Jesse James Artifacts

www.JesseJamesMuseum.org

Jesse James Birthplace
21216 Jesse James Farm Road
Kearney, MO 64060 • 816.736.8500

Jesse James Bank Museum
103 N. Water Street
Liberty, MO 64068 • 816.736.8510

LARAMIE

That's WY

10

OVER

WESTERN HISTORY MUSEUMS & MONUMENTS

- Ames Monument
- Laramie Plains Museum
- Laramie Railroad Depot
- Nici Self Museum
- Lincoln Monument Museum
- UW Anthropology Museum
- UW Art Museum
- UW Geology Museum
- Wyoming Territorial Prison
- Women's History House

Brochures:

- 8 Walking Tour Brochures
- Legends of Laramie Tour



WWW.VISITLARAMIE.ORG
1-800-445-5303

20 MORE MUSEUMS TO KNOW



— COURTESY BUFFALO BILL MUSEUM AND GRAVE —



— COURTESY THE BRINTON MUSEUM —

American West Heritage Center/Wellsville, UT

AWHC.org: The interpreters who work here take you on a journey into the lives of fur traders, pioneer residents and 19th-century shopkeepers. Pony rides, train rides and demonstrations of farming methods from 1917 bring history to life.

Armstrong County Museum/Claude, TX

ArmstrongCountyMuseum.com: The Palo Duro Ranch exhibit highlights the JA Ranch, and the museum operates the Charles Goodnight Historical Center in the Goodnight House and even keeps a buffalo herd descended from the animals once owned by Charles and Mary Ann Goodnight.

The Brinton Museum/Big Horn, WY

TheBrintonMuseum.org: Tucked away near the base of the Bighorns, the new Forrest E. Mars Jr. Building is a spectacular addition to the landscape. On display are permanent collections of Western art. And the museum hosts traveling exhibits such as this year's art and artifacts of the Plains Indians and artwork by Clyde Aspevig and Everett Raymond Kinstler.

Buffalo Bill Museum and Grave/Golden, CO

BuffaloBill.org: "From Prairie to Palace" shows artifacts, posters and graphic material associated with Buffalo Bill's European tours. A signature piece is Chief Red Shirt's breastplate, worn when the Lakota chief was in Brussels, and a beaded war shirt Chief Daniel Black Horn wore on his trip to Europe with Buffalo Bill.

Camp Floyd State Park and Museum/Cedar Valley, UT

StateParks.utah.gov: From a civil war camp event to history camps for kids, Camp Floyd shares stories of the frontier military and its connections to Utah.

Centennial Village Museum/Greeley, CO

GreeleyMuseums.com: The 35 historic structures here take you on a journey back in time to the period from 1866 to 1930. You'll find costumed interpreters and heritage farm animals.

City of Las Vegas Museum and Rough Rider Memorial Collection/Las Vegas, NM

LasVegasMuseum.org: This is where Teddy Roosevelt and his Rough Riders, a representative New Mexican home called La Casita and Santa Fe Trail history merge.

Cripple Creek District Museum/Cripple Creek, CO

CrippleCreekMuseum.com: Ignore the casinos and step into the mining history in the Colorado Trading and Transfer store, one of few surviving wooden buildings from the mining era.

Fort McKavett State Historic Site/Fort McKavett, TX

THC.state.tx.us: Combining the need for historic preservation with historic trades, Fort McKavett has some newly whitewashed walls, and volunteers knowledgeable about 19th-century construction techniques. The staff hosted two historical trades programs, teaching the skills while working in and around the buildings of the historic frontier post.

Fremont County Pioneer Museum/Lander, WY

FremontCountyWY.org: A "Mechanical Gardens" exhibit highlights antique farm equipment but this museum also has collections related to Native Americans and overland trails. Every Wednesday during the summer, visitors can listen to the drums and singers during Indian dance exhibitions.

Herzstein Memorial Museum/Clayton, NM

HerzsteinMuseum.com: Housed in what was once an Episcopal church, this museum claims a sassy ghost and shares history as diverse as Jewish settlement in New Mexico and Black Jack Ketchum.

House with the Eye Museum/Leadville, CO

LeadvilleTwinLakes.com: "The All Seeing Eye" is the signature exhibit of this historic house museum that houses 19th- and early 20th-century furnishings from the middle class of Leadville. The museum has both the original Eye, and a replica.

Knight Museum & Sandhills Center/Alliance, NE

KnightMuseum.com: Rogues, rascals and ranchers are among the characters you can learn about here, or dig into your own genealogy in the extensive research library.

Limon Heritage Museum/Limon, CO

LimonMuseum.com: See the restored Rock Island Railroad Depot or a boxcar filled with saddles. Visitors can take part in the annual Heritage Day celebration in early June.

Lincoln County Historical Museum/North Platte, NE

LincolnCountyMuseum.org: Thousands of troops spent time at the North Platte Canteen during World War II, which is one of the reasons to visit this historical museum. Among the others: The Maxwell Jail, blacksmith shops, and the Birdwood Schoolhouse.

Museum of Native American History/Bentonville, AR

Monah.us: Among the items you'll find in the extensive collections here are a Lakota wintercount hide, woolly mammoth skeleton, and Mississippian "head pots," which are some of the rarest of American Indian vessels.

The Kenedy Ranch Museum of South Texas/Sarita, TX

KenedyMuseum.org: The contributions of three generations of the Kenedy family to the development of South Texas and Texas Gulf Coast are honored at this museum. Don't miss the "Vaqueros" exhibit on the Kenedeños, "the people of the ranch."

The Nelson Museum of the West/Cheyenne, WY

NelsonMuseum.org: New acquisitions include an 1860 Starr Civil War revolver and a rare 19th-century inlaid bit made by a Wyoming State Penitentiary inmate.

White River Museum/Meeker, CO

RioBlancoCounty.org: There is so much local pioneer and American Indian history crowded into this museum, you'd better plan a long visit to explore.

Wyoming Territorial Prison State Historic Site

Laramie, WY/WyomingTerritorialPrison.com: Butch Cassidy slept here. Outside is a stagecoach with a history that begins in the 18th century and continues into the 21st century. Ben Kern drove the coach along the Overland Trail across Wyoming as recently as 2006.



Front Street, Dodge City, Ks
(620) 227-8188
www.boothill.org

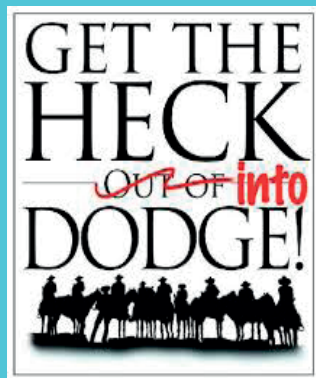

www.visitdodgecity.org



Boot Hill Museum is located on the original site of Boot Hill Cemetery and highlights the glory days of the Queen of the Cow towns with creative, lively, interactive displays and activities the entire family will enjoy. Boot Hill Museum is open all year long where you can belly up to the bar for a cold sarsaparilla, enjoy some of grandmas' homemade fudge in the General Store or take home a lasting memento of your old west experience from the Boot Hill gift shop.

During the summer months, children's activities, gunfight reenactments, country-style dinners and the Long Branch Variety Show provides entertainment like none other! Cool off with a painted lady in the Beatty and Kelley Ice Cream Parlor before you become a character of the past with a picture in the Old West Photo Parlor.

Relive the Legend at Boot Hill Museum in historic downtown Dodge City!



MUSEUMS BRING HISTORY TO LIFE

Celebrating Fort Smith History!

From frontier justice to national manufacturing center, you can experience it all at the Fort Smith Museum of History!

Relive the intriguing stories of over a century of Fort Smith life. Savor an old-fashioned soda in the 1920s pharmacy.

The Museum also presents special & traveling exhibitions.

Open Tuesday thru Saturday, 10 a.m. - 5 p.m.
Closed Sunday and Monday.

"Check our website for upcoming events and Summer hours"

www.fortsmithmuseum.com

Become a member of the museum today and help us continue to preserve history.



FORT SMITH
MUSEUM OF HISTORY

320 Rogers Avenue, Fort Smith, AR 72901
(479) 783-7841

Where the Present Meets the Past



See the fascinating history of South Texas come alive in vibrant murals and learn about the area's cultural, economic and religious development. View "Vaquero," a video describing cowboy life in the Wild Horse Desert.

Open Tues. - Sat. 10 a.m. to 4 p.m.
Sunday 12 noon to 4 p.m.

Admission: \$3 Adults
\$2 Seniors and Teens 13 - 18
Children 12 and under free

200 East LaParra Ave • Sarita, Texas 78385

Information: 361-294-5751

www.kenedymuseum.org

Northeastern Nevada Museum



Great Basin Home of Great Western Art

(Will James, Edward Borein & Others)

Bob Chow Gun Collection
Wildlife Habitat Dioramas From Around The World



www.MuseumElko.org
Elko, NV • 775.738.3418

Western History For All Generations

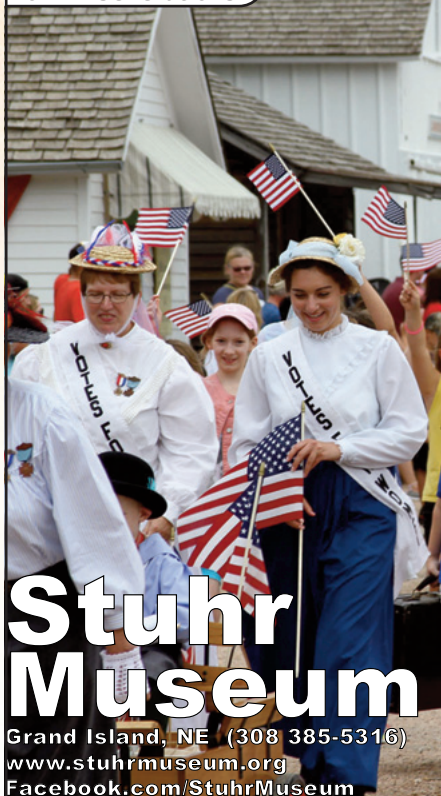

Stuhr Museum

Grand Island, NE (308 385-5316)
www.stuhrmuseum.org
[Facebook.com/StuhrMuseum](https://www.facebook.com/StuhrMuseum)

CELEBRITY MURDERED BY DISTURBED GUNMAN.

UNDERSTAND TODAY



GET THE REAL STORY.

Adams Museum

Days of '76 Museum

Historic Adams House

Homestake Adams Research and Cultural Center

Mount Moriah Cemetery



Visit the 1890's Gold Rush at

THE CRIPPLE CREEK District Museum



VOTED A TOP 10 WESTERN MUSEUM BY TRUE WEST MAGAZINE

Cripple Creek District Museum

5th & Bennett Avenue
Cripple Creek, CO 80813
719-689-9540

CrippleCreekMuseum.com

MUSEUMS BRING HISTORY TO LIFE

VAQUERO SHOW & SALE
November 11-13, 2016



SANTA YNEZ VALLEY HISTORICAL MUSEUM

Parks-Janeway Carriage House

Finest collection of American carriages, saddles and tack

Running model train diorama features early Pacific Coast Railway

History of early Valley towns, ranching heritage, pioneer life, vintage clothing, Native American artifacts and gift shop



805-688-7889 3596 Sagunto Street • Downtown Santa Ynez
santaynezmuseum.org Open Wednesday - Sunday, 12 noon to 4pm

One of True West Magazine's "Top 10 Western Museums"

Buffalo Bill Museum & Grave

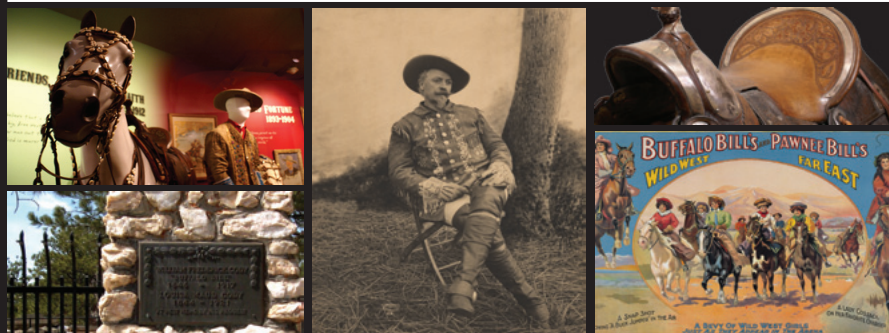

Now featuring:

New Permanent Exhibit "The Buffalo Bill Story"

New Online Photo Database

The Largest Museum Gift Shop in Colorado

Learn about it all at www.buffalobill.org



30 Minutes from Downtown Denver



CAVE CREEK MUSEUM

Tell your friends you saw Arizona's rare 10-Stamp Mill that dates back to 1880!

Ask us about our free monthly demonstrations!

(480) 488-2764

CaveCreekMuseum.org

6140 E Skyline Drive
Cave Creek, AZ



Museum of the Plains

1200 North Main
Perryton, TX 79070
(806) 435-6400
museumoftheplains.com

Showcasing the History of the Southern Plains

Exhibits include:

- Native American Painted Tipis
- The Buried City
- Buffalo Hunters
- Railroads and early settlement
- Over 4 acres of exhibits and historic buildings
- More than 20,000 artifacts
- Best historic book selection in the Texas Panhandle

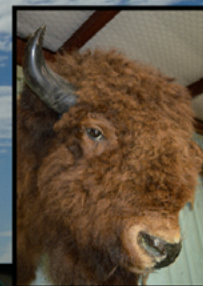

**TOP
10
MUSEUMS
OF THE WEST
2016**

The Nevada State Museum in Las Vegas presents numerous exhibits about the city and southern Nevada history, including an interactive railroad gallery about the boom-and-bust cycle of settlers in the crossroads community of Nevada's Mojave Desert.

- COURTESY TRAVELNEVADA -

6

NEVADA STATE MUSEUM
Las Vegas, NV

A private collection of materials from the *USS Nevada* battleship is the centerpiece of a new exhibit. The museum brought in veterans who served aboard the *Nevada* who shared their stories with ROTC members and the general public. A new exhibit, "Becoming Animal: Standing Witness for the Sentient Wild," debuts in October and will feature black-and-white photographs of the wild kingdom of Nevada's Mojave Desert taken by wildlife biologist and noted artist Sharon K. Schafer.

Museums.NevadaCulture.org

Restaurant & Saloon
Buffalo Bill's
IRMA HOTEL *est. 1902*

www.irmahotel.com

1192 Sheridan Avenue, Cody, WY • 307.587.4221 • 800.745.4762

TAKE A STEP BACK IN TIME!

VISIT US! STAY AWHILE!



*Stay in Historic
Rooms,
Enjoy the
Famous Irma
Prime Rib,
Relax in the
Silver Saddle
Saloon,
Watch the Cody
Gunfighters!*





— COURTESY CROOK COUNTY MUSEUM —

— COURTESY AMERIND MUSEUM —

— COURTESY ARCHWAY MUSEUM —

— COURTESY G.A. SMITH PIONEER VILLAGE —

10 MORE MUSEUMS TO WATCH

AMERIND Museum/Benson, AZ/Amerind.org: Johnny D. Boggs left this museum raving about its archaeological collection that includes rare baskets, Apache playing cards and a variety of cradleboards.

The Arabia Steamboat Museum/Kansas City, MO/1856.com: Mud encased the goods when the *Arabia* steamboat went down in the Missouri River in 1856. This museum tells the story of the discovery of the sunken *Arabia* discovery and showcases her rescued cargo—from fine china to leather shoes and blacksmith goods.

Crook County Museum/Sundance, WY/CrookCountyMuseum.com: Here you'll find dioramas of the Vore Buffalo Jump, Custer Expedition of 1874 and Devils Tower, plus knowledgeable folks who can inform you how to visit those sites in Crook County.

George A. Smith Pioneer Village/Provo, UT/ProvoPioneerVillage.org: Cabins and homes dating back well more than a century, plus business enterprises reflect the settlement history of Provo.

Grand Encampment Museum/Encampment, WY/GEMuseum.com: Celebrating 50 years in 2016, the museum is home to original structures including the Lake Creek Stage Station and a two-story outhouse.

Great Platte River Road Archway/Kearney, NE/Archway.org: Walk through history with the pioneers in this interpretive center that spans Interstate 80.

California Trail Interpretive Center/Elko, NV/CaliforniaTrailCenter.org: This extensive living history museum is dedicated to California Trail history and the people who toiled along its 2,000 miles to the Golden State.

Northfield Historical Society/Northfield, MN/NorthfieldHistory.org: Housed in the bank building that the James-Younger Gang tried to rob in 1876, the society tells the history of the famous bank robbery, as well as the larger community story.

The Stuhr Museum of the Prairie Pioneer/Grand Island, NE/StuhrMuseum.org: We like this museum for the opportunities to step back in time in its Railroad Town. Costumed guides populate historic community structures, including Henry Fonda's childhood home and the Taylor Ranch store.

Cave Creek Museum/Cave Creek, AZ/CaveCreekMuseum.org: The restored Golden Reef Ore-Crushing Stamp Mill, Arizona's only fully operational ten stamp mill, and three John Wade Hampton bronzes: *Throwing the Hooley-Ann*, *On the Prod*, and *Spooked*, are among the more than 70,000 artifacts in the museum collection.



**STORIES.
LEGENDS.
THE WEST.**

Sam Colt's personal cased pair of Colt Model 1851 Navy revolvers, 1860. Buffalo Bill Center of the West, Cody, Wyoming, USA. 1979.4.1.1

**BUFFALO BILL
CENTER
OF THE WEST**

**CODY
FIREARMS MUSEUM**



CODY, WYOMING

Smithsonian Affiliations

Official Interpretive Center for the
COLUMBIA RIVER GORGE
NATIONAL SCENIC AREA

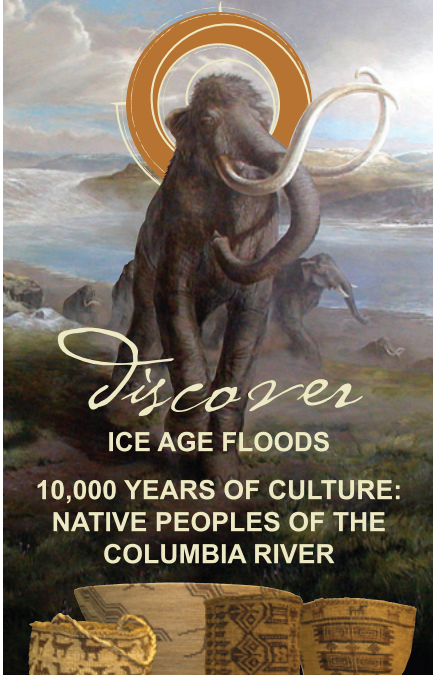

Discover

ICE AGE FLOODS

10,000 YEARS OF CULTURE:
NATIVE PEOPLES OF THE
COLUMBIA RIVER



explore



LEWIS & CLARK CARGO

JOHN C. FRÉMONT:
PATHFINDER OF THE WEST
through September 2016

END OF THE OVERLAND
OREGON TRAIL



inspire

HIKING TRAILS

LIVE RAPTOR PROGRAMS



COLUMBIA GORGE
DISCOVERY CENTER & MUSEUM

www.gorgediscovery.org
5000 Discovery Drive, The Dalles, Oregon

TOP
10
MUSEUMS
OF THE WEST
2016

7



YAKAMA NATION MUSEUM AND CULTURAL HERITAGE CENTER

Toppenish, WA

The Confederated Tribes and Bands of the Yakama Nation have built one of the most dynamic and interactive museums in the Northwest—the Yakama Nation Museum and Cultural Heritage Center, filled with numerous collections and exhibits dedicated to Yakama Nation history.

— COURTESY HEATHER C. HULL/YAKAMA NATION MUSEUM —

This center recognizes the most important American Indian leaders in the nation—from Sequoyah to Red Cloud and Chief Joseph. Every June the center holds a Treaty Day Ceremony to recognize the signing of the 1855 treaty. Exhibits focus on both cultural traditions and today's members of the Yakama Nation.

YakamaMuseum.com



COLUMBIA GORGE DISCOVERY CENTER & MUSEUM

The Dalles, OR

Ice Age Missoula Floods, geology of the Columbia Gorge, American Indian life, early explorers and the Oregon Trail are exhibit topics at this discovery center. One exhibit shows a wagon, with wheels removed, on a raft in the Columbia River, readying for the final leg of the Oregon Trail journey. A traveling exhibit on John C. Fremont, who passed through The Dalles in the fall of 1843 with Kit Carson and Thomas “Broken Hand” Fitzpatrick, is in place through most of 2016.

GorgeDiscovery.org

8

Located along the banks of the Columbia River in The Dalles, the Columbia Gorge Discovery Center & Museum is the largest, most comprehensive museum in Oregon dedicated to the cultural and natural history of the region.

— COURTESY COLUMBIA GORGE DISCOVERY CENTER & MUSEUM —

Regional Museums

State Historical Museum of Iowa
Des Moines, IA/IowaCulture.org

Jesse James Birthplace & Museum
Kearney, MO/JesseJames.org

Museum of the Big Bend
Alpine, TX/MuseumOfTheBigBend.com

Museum of The Mountain West
Montrose, CO/MuseumOfTheMountainwest.org

North Dakota Heritage Center
Bismarck, ND/History.ND.gov

Northeastern Nevada Museum
Elko, NV/MuseumElko.org

Riverton Museum
Riverton, WY/FremontCountyMuseums.com

Texas Ranger Museum
Waco, TX/TexasRanger.org

Saratoga Museum
Saratoga, WY/Saratoga-Museum.com

Yuma Territorial Prison Museum
Yuma, AZ/AzStateParks.com

Western Settlement

American Wind Power Center
Lubbock, TX/Windmill.com

British Columbia Barkerville Historic Town & Park
Barkerville, B.C., Canada/Barkerville.ca

Durango & Silverton Narrow Gauge
Railroad Museum
Durango, CO/DurangoTrain.com

Frontier Army Museum
Leavenworth, KS/Garrison.Leavenworth.army.mil

Museum of the Mountain Man
Pinedale, WY/MuseumOfTheMountainMan.com

Museum of the Plains
Perryton, TX/MuseumOfThePlains.com

National Oregon/California
National Historic Trail Interpretive Center
Montpelier, ID/OregonTrailCenter.org

National Mining Hall of Fame and Museum
Leadville, CO/MiningHallOfFame.org

Sacajawea Interpretive
Cultural & Education Center
Salmon, ID/SacajaweaCenter.org

Cowboys, Cattle and Ranching

Museum of the Cariboo Chilcotin
Williams Lake, B.C., Canada/Cowboy-Museum.com

National Ranching Heritage Center
Lubbock, TX/Depts.TTU.edu

New Mexico Farm and Ranch Heritage Museum
Las Cruces, NM/NMFarmAndRanchMuseum.org

Pawnee Bill Ranch and Museum
Pawnee, OK/OKHistory.org

Red River Valley Museum
Vernon, TX/RRVM.net

West Texas Trail Museum
Moorcroft, WY: (no website, call 307-756-9300)

Experience the Old West, the New West & the Next West



DESERT CABALLEROS WESTERN MUSEUM

21 N. Frontier St. • Wickenburg, AZ 85390 • 928.684.2272 • westernmuseum.org

Image: Joe Beeler, Thanks for the Rain, photo © Wayne Norton | © 2016 DCWM

THE
PANHANDLE
PETROLEUM
STORY

The grand story of oil in the Texas Panhandle

NOW OPEN

*Boring for oil at Adrian.
Photo from the Panhandle-Plains Historical Society Collection.*

*For hours, admissions,
special events and more
visit panhandleplains.org*

PPHM

PANHANDLE-PLAINS HISTORICAL MUSEUM

2503 Fourth Avenue
Canyon, Texas 79015

GOING TO THE SUN

ARTISTS IN GLACIER NATIONAL PARK



"I liked it so much I've gone back twice, and brought friends with me. The exhibit brings together Glacier-themed art from around the world, and it explains its connection to Charlie Russell who influenced a share of it."

—Tom Kotynski



C.M. RUSSELL MUSEUM

400 13th STREET NORTH
GREAT FALLS, MT

(406) 727-8787 • CMRussell.org

**TOP
10
MUSEUMS
OF THE WEST
2016**

9

The cattle trail that changed Western history celebrates its sesquicentennial in 2017. Travelers along the Old Chisholm Trail between Texas and Kansas should visit the Chisholm Trail Heritage Center in Duncan, Oklahoma, to learn about the trail's role in the development of the region.

— COURTESY CHISHOLM TRAIL HERITAGE CENTER —

CHISHOLM TRAIL HERITAGE CENTER

Duncan, OK

Preparing for the 150th anniversary of the Chisholm Trail in 2017 this museum features numerous permanent exhibits—"Romancing the Trail," "Folks on the Trail," "The Duncan Store"—plus a roping area, branding station, Chisholm Trail map and interactive kiosks like "How Old Am I?" and "On The Trail to Abilene." The kids can hear animals in "Ecology of The Trail," a diorama ecosystem that features life-sized taxidermy of a longhorns, buffalo, quail, turkeys, bobcats and more.

OnTheChisholmTrail.com

The Autry Museum of the American West has major exhibitions on the pantheon of Western history—ranging from film and television props such as Steve McQueen's gunbelt and "Mare's Laig" 1892 Winchester carbine from *Wanted Dead or Alive* to ranching dioramas of cowboy life on the range.

— COURTESY AUTRY MUSEUM OF THE AMERICAN WEST; WINCHESTER DONATED IN PART BY MR. DOUGLAS L. BOYER. AUTRY MUSEUM; 88.279.1.; GUNBELT DONATED BY THE RITTS FAMILY. AUTRY MUSEUM; 89.92.1. —



10

AUTRY MUSEUM OF THE AMERICAN WEST

Los Angeles, CA

A Winchester rifle presented to Dr. D. F. Powell "White Beaver" by W.H. Cody in 1881 is one of the new acquisitions at the Autry. But this year marked the opening of the newly renovated Cowboy Gallery, which now has a full-sized chuck wagon, artifacts exploring the tools and tasks of the cowboy including rare mid-19th-century California saddles, and hands-on activity stations for families. Also on display are William "Buffalo Bill" Cody's beaded buckskin jacket, Thomas Moran's painting *Mountain of the Holy Cross* and pistols given to Annie Oakley by her husband Frank Butler.

TheAutry.org

MUSEUMS BRING HISTORY TO LIFE

MEEKER COLORADO

WHITE RIVER MUSEUM

Telling the story of the Old West!

MILK CREEK BATTLEFIELD PARK
RURAL SCHOOL TOURS
NATIVE AMERICAN UTE EXHIBIT
OLD WEST COLLECTIONS



VISIT OUR ONE-OF-A-KIND CURIO MUSEUM!

FREE ADMISSION ~ DONATIONS ACCEPTED

565 PARK AVE. • MEEKER
970.878.9982

OPEN DAILY

www.rioblancocounty.org



LAURA INGALLS WILDER MUSEUM & INFORMATION CENTER

330 8th Street • Walnut Grove, MN 56180

Toll Free: (888) 528-7298
(507) 859-2358

lauramuseum@walnutgrove.org

www.walnutgrove.org

HOURS: June, July, August - Daily 10 a.m.-6 p.m.
May & September - Mon.-Sat. 10 a.m.-5 p.m.; Sun. 12 Noon-5 p.m.
April & October - Mon.-Sat. 10 a.m.-4 p.m.; Sun. 12 Noon-4 p.m.
Museum Buildings Closed Nov. 1 - March 31
Limited Gift Store Hours November thru March. Please call ahead.

- Veterans Display and Children's Area in Grandma's House Upstairs.
- 1890's Depot
- Chapel
- Grandma's House
- Walnut Grove Jail Cells
- Dugout
- Little Red Schoolhouse
- Early Settler's Home
- Heritage Lane
- Gift Store

Admission charged. The Laura Ingalls Wilder Museum is a non-profit organization working to preserve the history of Laura Ingalls Wilder and the community of Walnut Grove.

2017 PAGEANT DATES
JULY 14-15, 21-22, 28-29



Experience the TRUE STORY!

Come explore our new exhibits and reorganized displays.

Museum of the Mountain Man
Pinedale, WY

MuseumoftheMountainMan.com

307-367-4101



The Mark Twain
Boyhood Home
& Museum

*Voted as one of the
"is Best Small Town
Museums in the U.S."
by Fodor's Travel!*

Tour our historic properties and museums

Visit the Boyhood Home, a National Historic Landmark, Becky Thatcher's House, Huckberry Finn House, J.M. Clemens Justice of the Peace Office, Interpretive Center and the Museum Gallery for one ticket price.

Explore interactive exhibits for all ages

Wander through some of Sam's most famous novels. Ride a raft with Huck and Jim, explore a cave with Tom and Becky, pilot a steamboat and paint the famous fence.

View memorabilia from Sam's life

Get an up close view of Mark Twain's white jacket, Oxford gown and first editions of his works.



Home of 15 Original
Norman Rockwell Paintings

Open: 9 to 5 Daily
10 to 4 January through March 18th
Closed: Easter, Thanksgiving,
Christmas & New Year's Day

120 N. Main Street, Hannibal, MO

573-221-9010

www.marktwainmuseum.org



SUPERSTITION MOUNTAIN MUSEUM

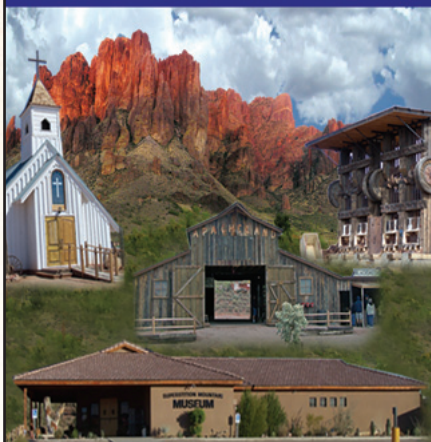

Discover
HISTORY & MYSTERY

PLAN TO ATTEND
HERITAGE DAYS
JAN. 14&15, 2017

480-983-4888

4087 N. Apache Trail (Hwy.88) Apache Junction, AZ 85119

www.superstitionmountainmuseum.org

COME VISIT

INDEPENDENCE HALL

BARRINGTON
LIVING FARM
HISTORY FARM

STAR OF THE
REPUBLIC
MUSEUM

FANTHROP
INN STATE
HISTORIC SITE



WASHINGTON ON THE BRAZOS

www.wheretexasbecametexas.org

936.878.2214

MUSEUMS BRING HISTORY TO LIFE

WELLS
FARGO

Visit Wells Fargo's History Museums



Anchorage • Phoenix • Minneapolis • Charlotte • San Francisco
Philadelphia • Portland • San Diego • Los Angeles • Sacramento
Des Moines

Details at wellsfargohistory.com/museums

© 2012 Wells Fargo Bank, N.A. All rights reserved. Member FDIC. ECG-705796

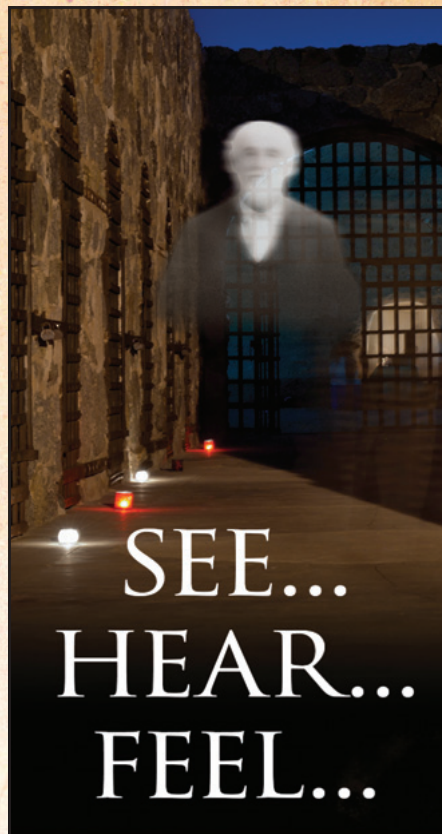

SEE...
HEAR...
FEEL...

THE GHOSTS OF PRISONERS PAST

Considered the "Alcatraz of the Desert", the Yuma Territorial Prison was called the "Hell Hole" by those sentenced there.

RELIVE THE LEGEND.

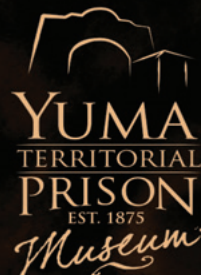

PRISON HILL RD.
YUMA, AZ
928.783.4771

YUMAPRISON.ORG



West Texas Trail Museum.....more than just trail dust...

A little bit of everything.....a whole lot of history....

Open Mondays through Fridays
9:00 am to 5:00 pm

FREE admission

100 E. Weston, Moorcroft, WY 82721
307-756-9300
Cynthia Clonch, Director

WestTexasTrailMuseum.com

~We are also on Facebook ~

Where History Meets the Imagination.



J. Henry Ray Indian Artifacts
.....

Quanah Parker Exhibit
.....

Doans Crossing & Western Trail
Interactive Exhibit
.....

Bill Bond Wild Game Exhibit
.....

"Largest Ranch Under One Fence"
The Waggoner Ranch Exhibit
.....

Electra Waggoner Biggs Sculpture Studio



4600 College Drive
PO Box 2004 • Vernon, TX 76385
(940) 553-1848 • (940) 553-1849

*Admission Required

Tue - Fri: 10:30 - 5:00 • Sat: 10:30 - 2:30

*Closed Sunday & Monday

52 years • 1964 - 2016

Celebrating our Past, Igniting our Future



We are on facebook as of right now!



The A.P. Hays Spirit of the West Collection at Western Spirit celebrates the history of the West through artwork, artisan collections and Western history exhibits. The Hayes collection of cowboy tack and gear, including spurs, hats, chaps and spur straps, is one of the most comprehensive in the world.

— COURTESY ABE HAYS FAMILY COLLECTION, WESTERN SPIRIT: SCOTTSDALE'S MUSEUM OF THE WEST —

TOP 6 ART MUSEUMS OF THE WEST 2016

THE EDITORS / WRITTEN
BY JOHNNY D. BOGGS

TOP WESTERN ART MUSEUMS HONOR THE PAST AND PRESENT



Western art remains hot. Just look no further than the success of art shows such as the National Cowboy & Western Heritage Museum's Prix de West and the Booth Museum's For the Love of Art Gala. And the \$11.4 million Western Spirit: Scottsdale's Museum of the West has already earned international acclaim in less than two years.

Certainly, many art lovers visit our Top Art Museums of the year to admire the works of 19th-century masters, but these museums also understand that 21st-century artists are creating their own visions. The American West has always been about change, and these museums keep evolving to stimulate patrons—even those of us who can't draw a stick figure.

Johnny D. Boggs recommends visitors to Santa Fe schedule a tour at the Wheelwright Museum of the American Indian.



**EXPLORE THE WILD WEST AT
BAKER HERITAGE MUSEUM**





33,000 square feet of exhibits including:

- ◊ 2016-2017 featured exhibit "Honoring Those Who Have Served"
- ◊ Rocks & Minerals
- ◊ 1900 Baker City
- ◊ Mining, Ranching and Logging
- ◊ Wildlife
- ◊ Chinese Culture
- ◊ Wally Byam & Airstream Trailers

**9308 Grove Street
Baker City, Oregon
541-523-9308**

ADLER HOUSE MUSEUM



Fully restored 1889 Italianate home of the Adler family. Original furnishings and wallpaper. Call for appointment.

**Celebrate Bandera
September 2 - 4**



**Come honor
our heritage**



**830-796-3045
BanderaCowboyCapital.com**

photo by Diana Byers



Hats

Hats were generally small for utility reasons. Riders did not want large brims interfering with their vision, with. However, better and half riders wore wide-brimmed hats that curled up at the sides. Prior to the 1950s, cowboy hats were monochromatic in color. If not in size, by the early 1950s it was the other way around, although some cowboys still wear the "ten-gallon" style. Colors have to be made, in reds, oranges, yellows, greens, blues, and purples, as well as the more usual colors of black, tan, brown and grey. Stetson hat styles such as those displayed in this exhibition, helped define the image of the American cowboy.

WORKING COWBOY

Stetson Hat
Made by John A. Stetson Co.,
Hats Division,
Stetson, Kansas
© 1998

Batwing Chaps

Chaps were first used as leg protection by the response which resulted for cattle in heavy brush, and guarded against eye burns, abrasions, and animal bites. There were three styles that included chaps, moccasins, and batwing chaps shown here. Many cowboys preferred the batwing chaps for their convenient snap-on closures.

WORKING COWBOY

Artisan-made gear, crafts and tack for the working cowboy make up a large part of the A.P. Hays Spirit of the West Collection, including these Stetson hats and batwing chaps.

- COURTESY ABE HAYS FAMILY COLLECTION, WESTERN SPIRIT: SCOTTSDALE'S MUSEUM OF THE WEST -



WESTERN SPIRIT: SCOTTSDALE'S MUSEUM OF THE WEST Scottsdale, AZ

A newcomer to the art scene (opening in 2015), this 43,000-square-foot, two-story venue in Old Town has quickly shot to the head of a talented pack of art museums. How? Well, the blend of history and educational programs is impressive, but you can't beat the vision. As director Mike Cox says, "We are not a museum of objects, but a museum of ideas."

ScottsdaleMuseumWest.org



**WESTERN &
AMERICAN INDIAN ART**
in a setting that's art unto itself



**MUSEUM
GALLERY
BISTRO
STORE**

OPEN DAILY
thebrintonmuseum.org
239 Brinton Road, Big Horn, WY
307.672.3173



Lone Star History Conference

Friday, April 29th - Sunday, May 1st

Join us for a three-day history conference featuring renowned speakers, leading historians and active-duty Texas Rangers on Texas Ranger history.

Featuring:

Assistant Chief Frank Malinak and
Lieutenant Wende Wakeman,
Texas Rangers

Bill O'Neal,
State Historian of Texas

David S. Turk,
U.S. Marshals Service Historian

Jim Willett,
Texas Prison Museum

www.texasranger.org



Gateway to the Rocky Mountain Continental Divide Trail



Plenty of wide open spaces
to play, fish, & hike.
Chama has family fun
and adventure.



The Cumbres & Toltec Scenic Railroad
Starts Memorial Day Weekend.
4th of July Fireworks Train & Display.
Chama Days ~ 2nd Weekend in August.
Chama Valley Studio Tour~
Labor Day Weekend.



Come to Chama, New Mexico
Experience adventure in the High Country.
Lodging, fine dining, festivals, events &
steam train excursions all Summer.

(800) 477-0149 or (575) 756-2306
info@chamavalley.com

VISIT CHAMA

Your Ticket to Adventure

No Expiration Everyone Welcome



CHAMATW.COM



Funding Provided by the Village of Chama Lodgers Tax
Photos: exploreandlistop.com, Roger Hogan, Jessica, Lynn Lamoreux



**TOP
6 ART
MUSEUMS
OF THE WEST
2016**

The Whitney Western Art Museum at the Buffalo Bill Center of the West in Cody, Wyoming, is home to one of the nation's most significant collections of Western American art, including William Ranney's 1853 oil on canvas, *Advice on the Prairie*.

- COURTESY BUFFALO BILL CENTER OF THE WEST, CODY, WYOMING, USA. GIFT OF MRS. J. MAXWELL MORAN. 10.91-

2

WHITNEY WESTERN ART MUSEUM Cody, WY

You don't get to see just an amazing collection of artists representing then and now, but the reconstructed studios of Frederic Remington and Alexander Phimister Proctor and Joseph Henry Sharp's original studio provide insight into those Western visionaries.

CenterOfTheWest.org



A HISTORY THIS RICH REQUIRES A GREAT STORYTELLER

Hours of Operation

Tues.-Sat. 9 a.m. - 5 p.m.; Sun. 1 p.m. - 5 p.m.; Mon. Closed

Free Admission

On the campus of Sul Ross State University
Entrance 4 off Harrison (Loop Road) - Native Rock Building
Free Parking at back of museum. Walk around to the front for entrance.

© Photo by Jim Bones



www.museumofthebigbend.com

Like Us on Facebook

432.837.8143

3

BRISCOE WESTERN ART MUSEUM San Antonio, TX

The upcoming “Ansel Adams: Distance and Detail Photographs from the Bank of America Collection” (September 15-December 15) is exciting, but this museum is always tremendous. Pssst. Tuesday nights are free from 4-9 p.m.

BriscoeMuseum.org

The Briscoe Western Art Museum in San Antonio, Texas, opened with great fanfare in 2013 and has quickly gained an international reputation as one of the finest Western museums in Texas and in the United States.

— COURTESY BRISCOE WESTERN ART MUSEUM —



GET IN TOUCH WITH THE OLD WEST



- Interactive exhibits
- Movies and interpretive programs
- Hiking Trails
- Gift shop
- Free admission all ages



AT THE CALIFORNIA TRAIL INTERPRETIVE CENTER



Elko, NV • I-80 Exit 292 • www.californiatrailcenter.org • 775-738-18497

**Visit
Deming
Luna Mimbres
Museum!**

**301 S Silver
Deming NM
575-546-2382**

www.ExploreDeming.com

Not Just
A Place...
But A
Destination

Deming Luna Mimbres Museum is
NEW MEXICO Fine





**PAWNEE BILL
RANCH & MUSEUM**



Maj. Gordon W. Lillie

This 500 acre historic ranch was once the showplace of wild west showman Gordon W. Lillie (Pawnee Bill). Visitors can tour his 1910 mansion, museum, ranch buildings, bison, horses and longhorn cattle in the drive-through pasture. The Ranch is also a day use park and picnic facility complete with shelters and a fishing pond.

Pawnee Bill's Original Wild West Show
Historical Reenactment
June 9th & 10th, 2017

All Day Festivities
Activities at 2:00 p.m.
Meal at 5 p.m.
Show starts at 7:30 p.m.



Museum Hours:
Tuesday ~ Saturday: 10 a.m. to 5 p.m.
Sunday ~ Monday: 1 p.m. to 4 p.m.
Closed Monday - Tuesday: November to March
1141 Pawnee Bill Rd, Pawnee, OK 74058

For more info call:
918-762-2513
or visit



PawneeBillRanch.org



4

**TUCSON MUSEUM OF ART
Tucson, AZ**

While "Welcome to the American West!" highlights 200 years of Western art, we can't wait to see "The New Westward: Trains, Planes, and Automobiles That Move the Modern West" exhibit (October 15-February 12).

TucsonMuseumOfArt.org

The Tucson Museum of Art's permanent collection of Western American art stresses the diversity and breadth of the genre, including classic and modern Western art and sculpture, while rotating exhibitions host national touring art shows from around the country.

- COURTESY TUCSON MUSEUM OF ART -

10 MORE ART MUSEUMS TO WATCH

Wheelwright Museum of the American Indian

Santa Fe, NM/Wheelwright.org: The Jim and Lauris Phillips Center for the Study of Southwestern Jewelry, which opened last year, is incredible.

A.R. Mitchell Museum of Western Art

Trinidad, CO/ARMitchellMuseum.org: Wonderful works by Arthur Roy Mitchell, Harvey Dunn and Harold Von Schmidt highlight the glorious Western pulp age.

National Cowboy & Western Heritage Museum

Oklahoma City, OK/NationalCowboyMuseum.org: Don't miss "Power and Prestige: Headdresses of the American Plains" (closes May 14).

The Bryan Museum/Galveston, TX

TheBryanMuseum.org: Seventy-thousand items cover 12,000 years of art, including Indian works, saddles, spurs and antique firearms.

Robert Henri Museum/Cozad, NE

RobertHenriMuseum.org: See the largest collection of original sketches by Robert Henri in his childhood home.

Brigham Young University Museum of Art/Provo UT

MOA.BYU.edu: Frederic Remington and Maynard Dixon are just two highlights in the long-running "Shaping America: Selected Works" from the Permanent Collection of American Art exhibit.

Booth Museum of Western Art/Carterville GA

BoothMuseum.org: There's still time to check out 60 years of Western art from Ray Kinster (closes October 2) and "By Her Hand: Native American Women, Their Art, and The Photographs of Edward S. Curtis" (closes November 20).

Art Museum of South Texas/Corpus Christi, TX

ArtMuseumOfSouthTexas.org: Texas Modernist Dorothy Hood gets her due in "Dorothy Hood: The Color of Being/El Color del Ser" (September 29-January 8).

Nelson Atkins Art Museum/Kansas City, MO

Nelson-Atkins.org: An impressive array shows works by American Indians and Missourians George Caleb Bingham and Thomas Hart Benton.

Museum of Northern Arizona/Flagstaff, AZ

MUSNAZ.org: The beautiful facility is known for its collection of Navajo and Hopi art.

STARK MUSEUM OF ART®

Stunning land ■ Dramatic people ■ Diverse wildlife

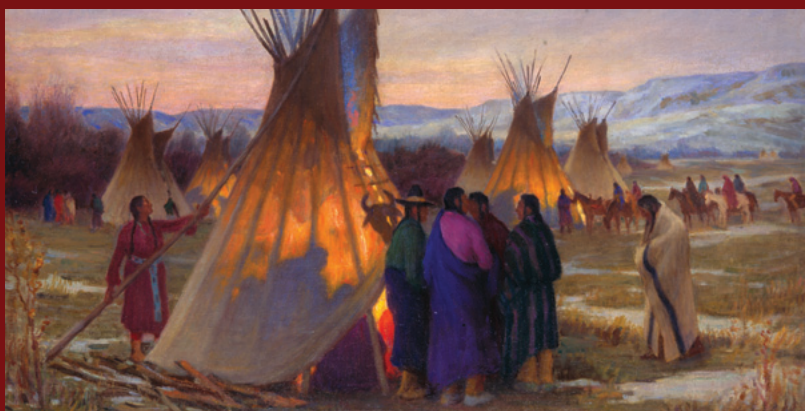

View one of the most significant collections
of American Western art

712 Green Avenue, Orange, TX starkmuseum.org

Thomas Moran (1837-1926), *The Mirage* (detail), 1879, oil on canvas, 25.125 x 62.375 in., 31.18.15. Alfred Jacob Miller (1810 - 1874) *Lost on the Prairie* (detail), after 1837, oil on canvas, 20 x 24 in., 31.34.1; Joseph Henry Sharp (1859-1953) *Council Call of Crows* (detail), Montana 1898, oil on canvas, 20.125 x 30.25 in., 31.25.35 Stark Museum of Art, Orange, TX. ©2016 All Rights Reserved.



5

STARK MUSEUM OF ART Orange, TX

Art museums across America must be envious of this spectacular collection of the works of George Catlin, Alfred Jacob Miller, John Mix Stanley, Albert Bierstadt, Thomas Moran, Frederic Remington, Charles Marion Russell and other 19th- and 20th-century masters.

StarkCulturalVenues.org

The Stark Museum of Art's world-class permanent collection of Western art masters—including Charles M. Russell's 1909 pen and ink and watercolor on paper, *The Trail is Long* [To Will Crawford]—draws visitors from around the world to Orange, Texas.

- COURTESY STARK MUSEUM OF ART, ORANGE, TEXAS, 11.106.27 -

LEGENDS OF THE WEST AUCTIONS DALLAS | LIVE & ONLINE

Consign Your Collection to Receive Epic Results!

Pictured here are some of the fine items sold in our June *Legends of the West* auction. Please don't miss our fall auction offerings! If you have a historically-oriented Western collection, or a noteworthy single item to sell, please contact us to discuss consignment opportunities.



Iconic 1881-dated belt from Tombstone legend "Buckskin Frank" Leslie
SOLD for \$32,500



Moccasins which belonged to famous Oglala Sioux Chief Red Cloud
SOLD for \$23,750



Indian gun recovered from the Wounded Knee battlefield
SOLD for \$55,000



1881 license for a Tombstone "House of Ill Fame" signed by Virgil Earp
SOLD for \$11,875

View all prices realized online at HA.com/Historical

For more information, please contact Tom Slater at 214-409-1441 or TomS@HA.com

DALLAS | NEW YORK | BEVERLY HILLS | SAN FRANCISCO | CHICAGO | PALM BEACH
PARIS | GENEVA | AMSTERDAM | HONG KONG

Always Accepting Quality Consignments in 40 Categories
Immediate Cash Advances Available
950,000+ Online Bidder-Members

HERITAGE
AUCTIONS
THE WORLD'S LARGEST
COLLECTIBLES AUCTIONEER

C.M. RUSSELL MUSEUM

Great Falls, MT

Yes, there are great temporary exhibits on Glacier National Park artists and John James Audubon, but the focus is always on Charlie Russell, where you can step inside his log-cabin studio, built in 1903.

CMRussell.org



6

The Russell Riders Sculpture Garden at C.M. Russell Museum in Charles M. Russell's adopted hometown of Great Falls, Montana, welcomes visitors to the internationally acclaimed gallery, and includes Joe Halko's life-sized bronze of grizzly bears, *Nose to the Wind*.

— COURTESY C. M. RUSSELL MUSEUM —



IMMERSE YOURSELF IN THE STORY OF THE WEST



WESTERN SPIRIT

SCOTTSDALE'S MUSEUM OF THE WEST



Charles M. Russell, *Fighting Meat* (aka *Horse and the Hunter*), 1919, oil on canvas; Courtesy Tim Peterson Family Collection.



- ◆ Rotating exhibitions of Western art spanning over a century
- ◆ Authentic Old West badges, guns, cowboy gear and other artifacts

3830 N. Marshall Way ◆ Scottsdale, Arizona ◆ 480-686-9539 ◆ scottsdalemuseumwest.org

TRADING POST

GOLDEN GATE WESTERN WEAR

Old west and contemporary hats, apparel, boots, and accessories for the whole family. Our custom hats are hand-formed by Bill Knudsen-**Reader's Choice Best Hatmaker** four years in a row! Can't wait? We have **quick-ship** stock hats too.

R.Crowe
3:10 To
Yuma



The Good,
The Bad,
& The Ugly



See our online catalog at
www.KnudsenHats.com
ORDERS: (510) 232-3644

Historic EyeWear Company

Keeping History in Sight

Spectacle Outfitters to the Old West



Protect your eyes from the damaging rays of the prairie sun in our Old West style reproduction antique spectacles.

Ophthalmic Quality
PRESCRIPTION READY
Historically Accurate

www.HistoricEyeWearCompany.com
862.812.4737

CATALENA HATTERS

*Fits Right.
Looks Right.
Feels Right.*



The Gus



Telescope

800-976-7818 - www.catalenahats.com

The Official

LOUIS L'Amour

TRADING POST

Exclusive Louis L'Amour products plus all of his novels, short stories, non-fiction, poetry, audio books & CDs, branded clothing, MP3's, DVD movies and more!

WWW.LOUISLAMOUR.COM
The Home of America's Favorite Storyteller



3 Hours on 3 CDs
ONLY
\$19.99

Deep within the jungles of Borneo flows a legendary river of diamonds... A dramatized audio tale of love, redemption, heroism, and magic from the master storyteller.
Order your copy today!
1-800-532-9610



Helping collectors and history buffs learn more about specific events and people in American history.

Guidon Books

The largest collection of new and out of print Civil War & Western Americana books.

Lincoln and Custer Collections, American Indian History, Arts & Crafts.

Bookmaster@Guidon.com • Guidon.com

ONLINE SALES OR VISIT US AT OUR NEW LOCATION
7830 E. Redfield Rd. Suite 1
Scottsdale, AZ • 480-945-8811

 Follow us on Facebook!



Lawman Holster/Belt Combination—\$111



Single Huckleberry—\$116
Double Huckleberry—\$203



Favorite Western Icon Buckle—\$30

Authentic 1800 working cowboy clothing, leather, spurs and more.
Call for a free catalog 509-782-3018
westernandwildlifewonders.com
info@westernandwildlifewonders.com

Western and Wildlife Wonders

Single Action Pistol Grips by TeePee Creeper

WESTERN ROUNDUP

FOR SEPTEMBER 2016



CELEBRATE BANDERA

Bandera, TX, September 2-4: Bandera comes alive with music, gunfights, an intertribal powwow, a Wild West show and a mutton busting rodeo. 970-247-3555 • CelebrateBandera.com

ART SHOWS

LOCALS FIRST: WESTERN ART OF JIM BAGLEY & JENNY GUMMERSALL

Durango, CO, September 1-30: See contemporary Western paintings by Jim Bagley and Americana-style photography by Jenny Gummersall. 970-247-3555 • SorrelSky.com

BOSQUE ART CLASSIC

Clifton, TX, September 10-24: Cowboy Artists of America bronze sculptor Jason Scull directs the judging at this year's juried art show. 254-675-3724 • BosqueArtsCenter.org

MUSEUM OF WESTERN ART'S ART SALE AND EXPEDITION

Kerrville, TX, September 17: Shop and view art by contemporary Western artists, as well as take museum tours and eat a chuckwagon breakfast. 800-658-2548 • MuseumOfWesternArt.com

HERITAGE FESTIVALS

WINNEMUCCA TRI-COUNTY FAIR & STAMPEDE

Winnemucca, NV, September 1-4: Locals in Winnemucca and its surrounding counties gather to honor their cowboy heritage and culture. 800-962-2638 • Winnemucca.com

SOUTH DAKOTA STATE FAIR

Huron, SD, September 1-5: Watch Cowboy Mounted Shooting, an antique tractor show and musical performances by Dwight Yoakam and others. 605-353-7340 • TravelSouthDakota.com

OLD WEST COWBOY DAYS

Ottawa, KS, September 2-4: Celebrates cowboy culture with a Main Street cattle drive, bourbon train ride and a Texas Hold 'em tournament. 785-423-1585

[Facebook.com/Ottawa-Cowboy-Days](https://www.facebook.com/Ottawa-Cowboy-Days)

GOLD RUSH DAYS

Sacramento, CA, September 2-5: Go back in time to 1850 Sacramento where you can pan for gold, gamble and drink sarsaparilla. 800-292-2334 • SacramentoGoldRushDays.com



ROCK ISLAND PREMIERE FIREARMS AUCTION

Rock Island, IL, September 9-11: Bid on collectible weapons from the Robert M. Lee firearms collection, as well as the above recently discovered national treasure, the J. Russell & Co. hunting knife that was presented to President Theodore Roosevelt.

800-238-8022 • RockIslandAuction.com

HEBER VALLEY
WESTERN MUSIC
& COWBOY POETRY
GATHERING



Presented by:

ZIONS BANK
LIFE UTAH
ELEVATED

UTAH'S LARGEST
CELEBRATION *of the*
AMERICAN WEST

with Music, Poetry & Art

MAIN SHOWS

HOST, WADDIE MITCHELL
MICHAEL MARTIN MURPHEY
BAR J WRANGLERS • SUZY BOGGUSS
THE HIGHWAY MEN
WYLIE AND THE WILD WEST
JONI HARMS • BELINDA GAIL

MAIN EVENTS

WILD WEST TRAIN • DINNER SHOWS
BUCKAROO BALL • COWBOY CHURCH
MOUNTED SHOOTERS & MORE!

OCT. 26-30, 2016
HEBER CITY

TICKETS ON SALE NOW!
HVC PG.COM

WESTERN ROUNDUP
FOR SEPTEMBER 2016

ANNUAL BIVOAC & NATIONAL CALVARY COMPETITION

El Reno, OK, September 21-24: Thundering hooves, gleaming sabers and the call of the bugle charge all return to the 1875 post, Fort Reno.
405-262-3987
USCalvary.org

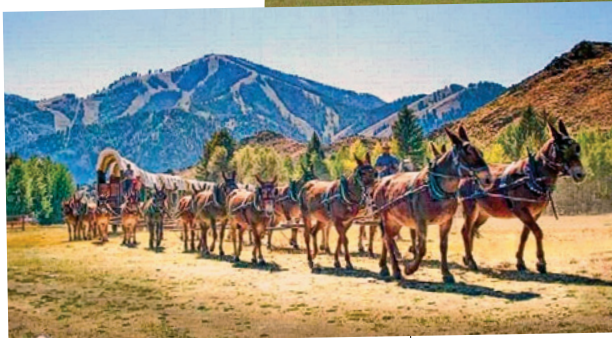

WAGON DAYS

Ketchum, ID, August 22-September 5: Features one of the largest non-motorized parades in the Pacific Northwest, plus wagons and stagecoaches.
208-726-2777
WagonDays.org

FIESTA DE SEPTIEMBRE

Wickenburg, AZ, September 3: Mariachi music, folklorico dances and an outdoor *mercado* liven up this Hispanic pioneer heritage festival.
928-684-5479 • WickenburgChamber.com

ELKO COUNTY FAIR & HORSE RACES

Elko, NV, August 26- September 5: Elko County residents pay tribute to their pioneer heritage with livestock shows and horse races.
800-248-3556 • ExploreElko.com

HELLS CANYON MULE DAYS

Enterprise, OR, September 9-11: This mule show and sale features an Old World Oxen living history camp, plus cowboy music, poetry and art.
325-677-4376 • HellsCanyonMuleDays.com

MEDORA HOT AIR BALLOON RALLY & BADLAND KITE FEST

Medora, ND, September 10-11: Balloon and kite enthusiasts gather to soar over the South Dakota Badlands as spectators enjoy the view.
701-623-4830 • Medora.com

HAPPY CANYON INDIAN PAGEANT & WILD WEST SHOW

Pendleton, OR, September 14-17: The outdoor "Pageant of the West" show honors American Indian heritage and the settling of the West.
800-457-6336 • HappyCanyon.com

HARVEST FESTIVAL

Gering, NE, September 17-18: Honors Nebraska's agricultural history with parades and demonstrations at Legacy of the Plains Museum.
308-436-1989 • LegacyOfThePlains.org

TERRITORIAL DAYS

Tombstone, AZ, September 17-18: Experience Tombstone's territorial history with a military encampment, chuckwagon cook-off and grand ball.
888-457-3929 • TombstoneForward.com

MUSIC & POETRY

NATIONAL COWBOY SYMPOSIUM & CELEBRATION

Lubbock, TX, September 9-11: Celebrate cowboy culture at one of the West's biggest chuckwagon cook-offs, plus enjoy cowboy music and poetry.
806-798-7825 • Cowboy.org

PILGRIMAGE MUSIC & CULTURAL FESTIVAL

Franklin, TN, September 24-25: Hall & Oates, Kacey Musgraves, Brothers Osborne and other Country artists perform at this music and cultural festival.
PilgrimageFestival.com

RE-ENACTMENTS

DEFEAT OF JESSE JAMES DAYS

Northfield, MN, September 7-11: Celebrate the town heroes who stopped the Jesse James Gang during their famous 1876 bank raid.
800-658-2548 • DJJD.org

SANTA FE RENAISSANCE FAIR

Santa Fe, NM, September 17-18: A 1700s ranch-turned-living history museum celebrates the Renaissance with sword fights and Irish dances.
505-471-2261 • Golondrinas.org

RODEOS

BULL RIDING & RANCH BRONC

Winner, SD, September 3: Riders go head to head for the purse in bronc and bull competitions while

OLD WEST BALLOON FEST

Scottsbluff, NE, September 3-5: Spectators gather to watch hot air balloons rise above this 1899 railroad town named after its famous landmark bluff, towering above the North Platte. 800-687-3722 • VisitScottsbluff.com



kids compete in mutton busting and horse races. 605-842-1533 • TravelSouthDakota.com

CAL FARLEY'S BOYS RANCH RODEO

Amarillo, TX, September 3-4: Features the rodeo talents of the boys and girls of Cal Farley's, ages three to 18, plus a free barbecue lunch. 800-687-3722 • CalFarley.org

WEST TEXAS FAIR & RODEO

Abilene, TX, September 8-17: West Texas cowboys and cowgirls head to this PRCA rodeo that also features a tractor pull and a carnival. 325-677-4376 • TaylorCountyExpoCenter.com

PENDLETON ROUND-UP

Pendleton, OR, September 14-17: A PRCA rodeo with cowboy concerts, Indian relay races, the Happy Canyon festival and a rodeo parade. 800-457-6336 • PendletonRoundUp.com

NAVAJO COUNTY FAIR & RODEO

Holbrook, AZ, September 14-18: Navajo County draws PRCA talent to its rodeo that also features carnival rides and a demolition derby. 928-524-4757 • NavajoCountyFair.com

SHOOTING COMPETITION

CLAYS CRUSHER FUN SHOOT

Artesia, NM, September 16-17: Shooting teams of five compete to shoot down the most sporting clays at a variety of challenging courses. 800-658-6251 • ArtesiaNM.com



STUDEBAKER CAR SHOW

Custer, SD, September 4: The oldest town founded in the Black Hills welcomes car enthusiasts for a street show of stock and modified Studebaker and Packard vehicles. 605-673-2244 • VisitCuster.com



TWMag.com:

View Western events on our website.

28th Annual NATIONAL COWBOY SYMPOSIUM & CELEBRATION®

September 9-11, 2016
Lubbock, Texas

Featuring Lubbock Memorial Civic Center



DAVE STAMEY



MIKE BECK

**WESTERN MERCHANDISE & ART
LIVE MUSIC & COWBOY POETRY
CHUCK WAGON FOOD & COFFEE
HORSE TRAINING DEMONSTRATIONS
NATIVE AMERICAN ACTIVITIES
YOUTH ACTIVITIES**

Tickets available online at
WWW.COWBOY.ORG
OR CALL 806.798.7825



THE BRYAN MUSEUM
THE WEST AS IT WILL NEVER BE SEEN AGAIN

CHECK OUR WEBSITE FOR ANY RECENT CHANGES

MUSEUM HOURS	ADMISSION
CLOSED TUESDAY AND WEDNESDAY	ADULT \$12.00
THURSDAY II AM - 4 PM	MILITARY \$10.00
FRIDAY II AM - 4 PM	SENIOR \$10.00
SATURDAY II AM - 4 PM	STUDENT \$10.00
SUNDAY II AM - 4 PM	AGE 6 - 12 \$4.00
MONDAY II AM - 4 PM	UNDER 6 FREE

1315 21ST STREET
GALVESTON, TX 77550

THE BRYAN MUSEUM
409.632.7685
THEBRYANMUSEUM.ORG

The OK Corral Gun

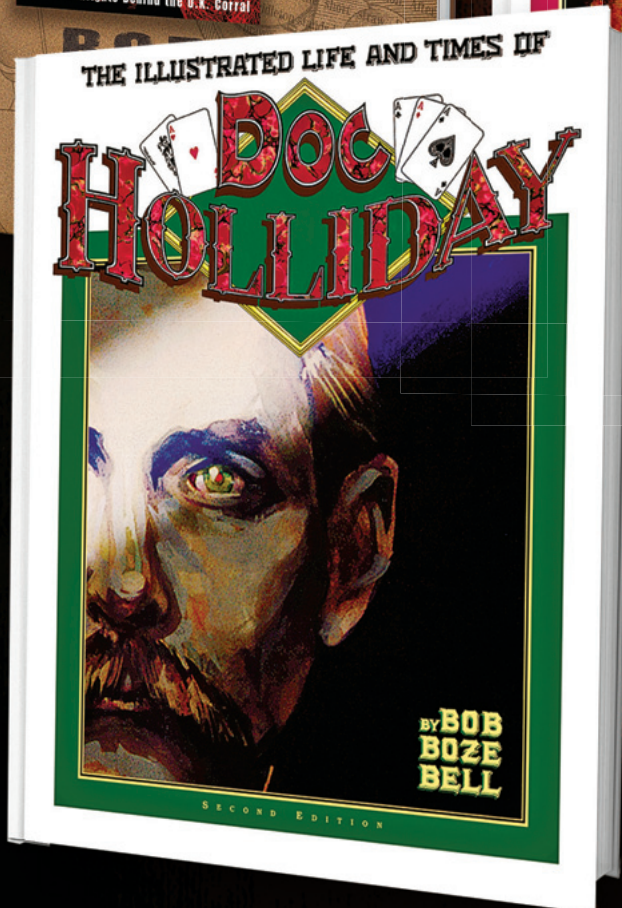
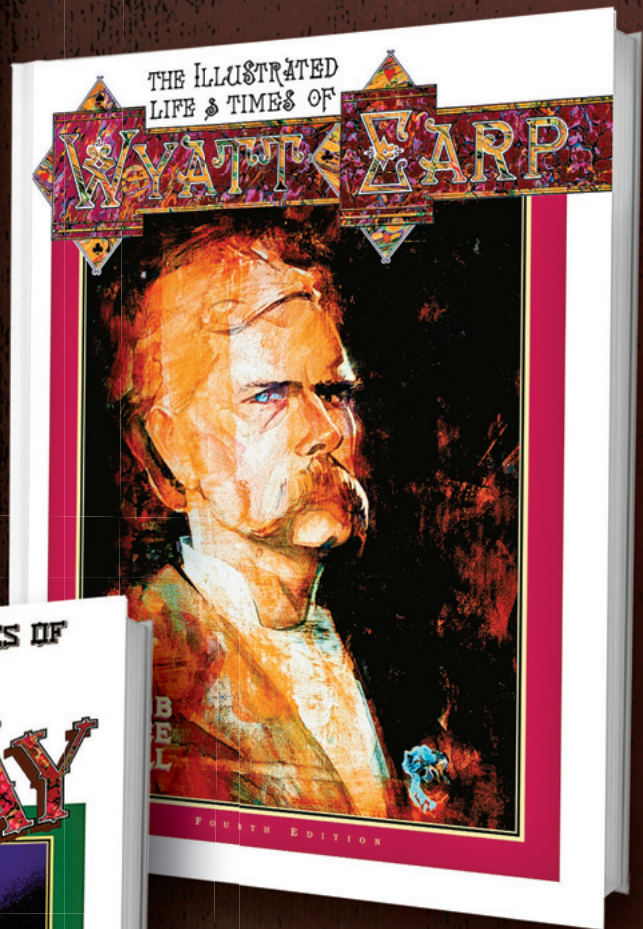
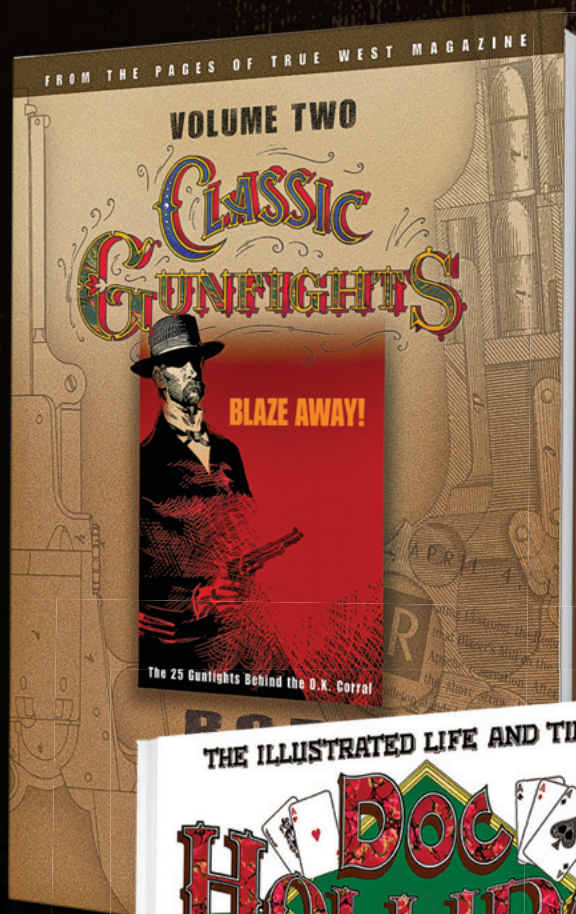

On Sale Now!

This is a limited time offer!
Available only while
supplies last!

\$85 plus S&H

fight Complete Set

"If you want to know how and why the O.K. Corral fight happened, these are the three books you have to have.

Bob Bell gives you definitive text with illustrations and maps that bring history to life."

— Allen Barra, author of *Inventing Wyatt Earp*

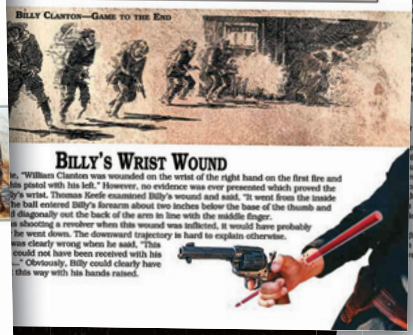
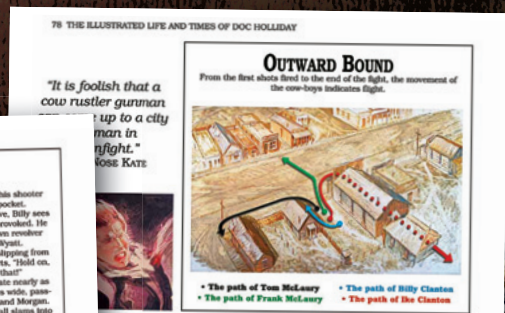
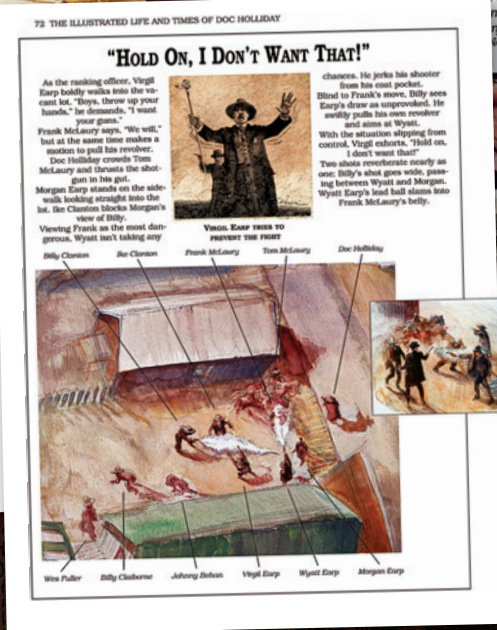
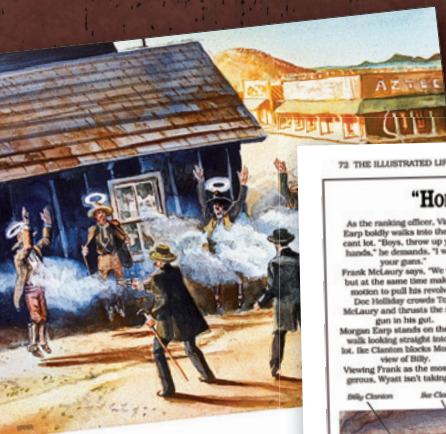

"That Wyatt Earp did willfully, unlawfully, deliberately, premeditatedly, feloniously, and with malice aforethought, kill or murder William Clanton, Thomas McLauray and Frank McLauray."
— A WARRANT ISSUED BEFORE
JUSTICE OF THE PEACE J. B. SMITH

Order your set today!

No collection will be complete without these 3 books.

Visit www.Store.TrueWestMagazine.com or Call: 1-888-687-1881



Pickled Jack Slade

What can you tell me about Jack Slade's wife?

Dan Bird
Cornelius, Oregon

Not a lot. Her first name is believed to be Maria Virginia, but her last name is lost to history. Historians do not know how she met Joseph Alfred "Jack" Slade or anything about her life before him. They married around 1858, and Jack may have called her Virginia Dale. Either her name came from a grassy glade near where he established a stage station in Colorado in 1862 or he named the station after her.

Old West author Leon Metz says Jack, despite all his shortcomings, loved the young lass—maybe too much. Some folks who knew the couple says Virginia manipulated Jack, pushing him to do some of the bad deeds that eventually got him lynched by vigilantes.

After he died on March 10, 1864, she planned to take his body to his hometown in Illinois. She filled his mostly tin coffin with alcohol and set out for Carlyle. Four months later, she reached Salt Lake City, Utah, but his body had become so odorous, she had him interred in a Mormon cemetery.

On March 22, 1865, Virginia remarried, to James Henry Kiskadden, a friend of Jack's who had witnessed the Montana vigilantes kill him. They divorced three years later, and she vanished.

Can a person ride his horse to death?

Ben Herndon
Los Angeles, California

Horses can run fast only so long, depending on the conditioning and the



Virginia Slade is an Old West mystery waiting to be solved.

— COURTESY CHARLES BOVEY COLLECTION —

breed. Quarter horses are bred for shorter distances, while Arab horses are noted for endurance. A horse can die of dehydration, heart attack and exhaustion if not rested periodically. Also, horses, like humans, can develop heart problems. Horses have died in the middle of a race or even afterwards.

Did the Wild West era have any famous deaf people?

Chris Graefser
St. Peters, Missouri

One who comes to mind is Erastus "Deaf" Smith, one of the most celebrated patriots in the Texas fight for independence. This soldier who became the eyes and ears of the Texas Army was going blind and nearly deaf.

His greatest contribution in the war was as a scout and spy, talents that influenced the Battle of Concepción on October 28, 1835, the Grass Fight on November 26, 1835, and, most important, the Battle of San Jacinto.

Just before the Battle of San Jacinto that sealed Texas independence, Gen. Sam Houston sent Smith and a group of hand-picked soldiers to remove and burn Vince's Bridge, thereby cutting off Mexican reinforcements and blocking any chance for Gen. Antonio López de Santa Anna to escape. The Texans knew this also kept them from retreating. The message was clear: "Victory or death."



Ask The Marshall

BY MARSHALL TRIMBLE

Marshall Trimble is Arizona's official historian and vice president of the Wild West History Association. His latest book is *Arizona's Outlaws and Lawmen*; History Press, 2015. If you have a question, write: Ask the Marshall, P.O. Box 8008, Cave Creek, AZ 85327 or e-mail him at marshall.trimble@scottsdalecc.edu

That victory came on April 21, 1836.

Smith organized a Texas Ranger company after the war, and he died on November 30, 1837. Deaf Smith County is named in his honor.

Oh, and folks pronounced his name "deaf" with a long e, not a short e.

My family connections include John Wesley Hardin and Clay Allison, both of whom had Tennessee ancestors. Did the outlaws ever meet?

Don Magers
Saltillo, Tennessee

"Wes Hardin never went to Tennessee," says author Dennis McCown. "Clay Allison's 'outlaw years' and death all occurred when Hardin was serving time in Huntsville Prison, Texas. I think we can 'bet the farm' they never met.

"John Wesley Hardin's relation to Tennessee is extremely remote. Hardin County was posthumously named after Hardin's great-grandfather, Joseph Hardin, a Revolutionary War hero. John Wesley's father, James Gibson Hardin, was born in

Tennessee, but came to Texas with his family when he was a teenager."

Chuck Parsons, who has authored books on both Hardin and Allison,

Clay Allison is shown here circa 1871, shortly after a self-inflicted gunshot wound in the foot.

— TRUE WEST ARCHIVES —



Painting of Erastus "Deaf" Smith by T. Jefferson Wright.

— COURTESY SAN JACINTO MUSEUM OF HISTORY —





William H. Jackson photographed Robbers Roost at the Virginia Dale stage station in Colorado in 1870.

— COURTESY NATIONAL ARCHIVES AND RECORDS ADMINISTRATION —

adds, “They never met and probably didn’t even know about each other.”

What is the Hole-in-the-Wall Pass in Wyoming?

*Terry Kelley
Ruidoso Downs, New Mexico*

The favorite sanctuaries for Butch Cassidy’s Wild Bunch were Hole-in-the-Wall, in northern Wyoming, Browns Park, in northeastern Utah, near the Wyoming and Colorado borders and Robbers Roost, in southeastern Utah. The wild country served the outlaws well.

Hole-in-the-Wall was not really a hole, but a narrow path along a cliff. The gang could guard the entrance, spot riders approaching from a great distance and easily defend the narrow passes. The men holed up there at Cassidy’s ranch along Blue Creek. The land is now private property, so you should get permission if you would like to visit the beautiful, remote location.

Did American Indians have some version of bathrooms or latrines?

*James White
Goliad, Texas*

American Indians generally did their “business” in the most convenient place not far from their tipis. Indians dug latrines away from the tipis and fresh water. During the most brutal weather, these latrines would be placed close by. Human waste froze in the winter and didn’t smell nearly as much as in the summer.

Just about everything the various tribes did or used was biodegradable. On the whole, Indian communities were far more hygienic than folks residing in European cities.



PLAN TO ATTEND
36th ANNUAL
HELLS CANYON MULE DAYS
ENTERPRISE, OREGON *Rated "E" for Everyone!*

The Weekend After Labor Day
SEPTEMBER 9-10-11, 2016
Enterprise, Oregon

- MULE SHOW & SALE
- NON-MOTORIZED PARADE
- SAT. NIGHT PIT B-B-Q
- VINTIQUES SHOW— MULE CLINICS
- D.O. COOK-OFF – COWBOY CHURCH
- COWBOY POETRY GATHERING
- VENDORS/EXHIBITS & WESTERN GEAR
- MULE ARTIST – BONNIE SHIELDS
- SAT. CONCERT – JONI HARMS



SHOW INFO: SONDRALOZIER
541-426-3271 or 541-263-0104
visit: www.hellscanyonmuledays.com

EXPERIENCE A GREAT TIME IN N.E. OREGON



TEXAS RANGERS HERITAGE CENTER



COURAGE • DETERMINATION • DEDICATION • RESPECT • INTEGRITY

The Ranger Ring of Honor, a 30' diameter badge memorial, dedicated to honor those **TEXAS RANGERS** who made the ultimate sacrifice providing safety and protection to the people of Texas.

The Texas Rangers Heritage Center is nestled between Fort Martin Scott and Baron's Creek on East Main Street in Fredericksburg, Texas. The Texas Rangers Heritage Center is dedicated to the preservation of Texas Ranger history for the education of our youth.

★★★★★
TEXAS RANGERS HERITAGE CENTER
Open from 9 AM to 5PM, Thu-Mon.
1618 E. Main St. Fredericksburg, TX 78624
(830) 990-1192 • www.trhc.org



THE BEST COWBOY BAR IN THE WEST

AND

Live Music
Great Food
Never Ending Fun!
Hangings by Appointment

11 TAP BEERS
AND OUR SAUZA MARGARITA

Open Daily 10:00AM
520.457.3107
417 E. Allen Street
www.bignosekate.com



Once The Grand Hotel.
BIG NOSE KATE'S
is a legend and a
NATIONAL HISTORIC LANDMARK

What HISTORY HAS TAUGHT ME

My character on *The High Chaparral* was not supposed to be Bobby Hoy's character's younger brother. But when we filmed it, I called him my younger brother, and Director Bill Claxton said, "Guess what? He is your younger brother now 'cause I'm not shooting the scene again."

On NBC's *Outlaws*, I learned never to let your costar pick out his own spurs. Bruce Yarnell put on some big Mexican rowels. Away he went, and those spurs almost got him killed!

I became a 1980s icon as "Gumfighter" in the Hubba Bubba commercial for Wrigley's gum. I was the bubble gum-toting sheriff who got the bad guys by blowing bubbles for eight years, and I made \$700,000.

My "Pick up the Pace" Pace Picante commercials happened because they liked the way I delivered the line.

While serving in the U.S. Navy, I cut one of my fingers off in an accident aboard the *USS Astoria*, a light cruiser. It happened in the handling room of a 5X mount (a cannon). The breach caught my middle finger, right hand. That's an important finger, you know.

I got in the movie picture business through Francis Lederer, a European actor who did quite well in Hollywood. When I got out of the Navy in 1946, I worked on his San Fernando Valley ranch, branding calves and horseback riding.

On a John Wayne movie, after the director yelled, "Cut," you never left the set. I liked working with Wayne, and he was a taskmaster, but you'd better know your lines and show up on time. When the director yelled, "Cut," you didn't leave; you stayed by the camera. That was Wayne's work ethic; you followed that ethic. I've always admired him for that.

Elvis Presley pushed me into a dessert cart in a movie called *Paradise, Hawaiian Style*.

I had a football scholarship in 1949, in Abilene, Texas; I only lasted one season. I played left end. I was good at it, but I wasn't any kind of a scholar.

I didn't kiss many women on screen, but I sure enjoyed kissing Rhonda Fleming. That was on *Death Valley Days*!

My favorite acting experience was *The High Chaparral*, because it functioned like a working ranch and it was



The craziest thing that ever happened to Don Collier on set took place while filming the Hubba Bubba bubble gum commercial. He wasn't good at blowing bubbles, so a stunt bubble gum blower blew up the bubble and then handed it to Collier to put in his mouth for the commercial.

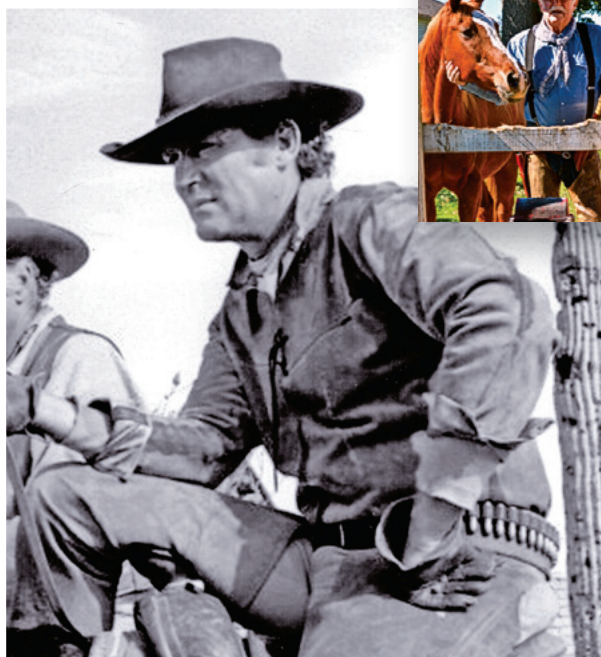

PHOTOS COURTESY THEHIGHCHAPARRALREUNION.COM

DON COLLIER, ACTOR

The father of six kids, Don Collier is well known as a Western actor. He broke into the genre in 1948, graduating from an extra in *Massacre River* to acting in the John Wayne flick, *Fort Apache*. In the 1960s, he earned the lead role in NBC's *Outlaws*, following that up with appearances in other shows, before getting cast as the ranch foreman in the long-running *The High Chaparral* series. Next year, on March 17-19, in Tucson, Arizona, Collier plans to reunite with cast members for the 50th anniversary of *The High Chaparral*.

like a real family. It lasted four seasons. I wish it had been 10, but I'll take it.

I just watched *The Revenant*, and I thought it was fantastic. That young fellow—DiCaprio—was just excellent, and the movie deserved every award it got.

Fred Imus was a great guy, and I worked with him on Fred's Trailer Park Bash radio show for about five years. He was a terrible slob though and left trash all over his trailer. But he was a pretty good slob!

Nobody knows that I like working with a wood lathe. I make plates, lamp bases and dishes. I mostly use mesquite wood that is native to Arizona. It makes me happy.

A project I am working on now is called "The West of the Story," about 19th-century events—stagecoach robberies, bank robberies, hangings and that sort of thing. I'm almost 88 in October, so I better get it done.



Historic Montana
Horse Ranch



Calamity Jane Horse Cache ■ 1716± acres ■ \$3,595,000

Steeped in western lore, the *Calamity Jane Horse Cache* has a rich history dating back to the 1800s when “Calamity Jane”, watered her horses at the ranch’s Canyon Creek.

Offered for sale for the first time in over 23 years, the ranch is a prime conservation candidate to preserve a historic legacy.

FAY
RANCHES_{INC.}

LandReport
2011-2016
BEST
BROKERAGES

You can view available properties and
request a complimentary subscription to
Land Investor magazine at:

FAYRANCHES.COM | 800.238.8616

FARMS ■ TIMBER ■ RANCHES ■ PLANTATIONS



Rock Island Auction Company® Proudly Unveils A Recently Discovered National Treasure

TO BE OFFERED AT OUR

SEPTEMBER 9TH, 10TH & 11TH PREMIERE FIREARMS AUCTION

3 DAY LIVE PUBLIC AUCTION

OVER 2700 LOTS



*Theodore
Roosevelt*



*James W.
Gerard*

The Finest and Most Historic American Bowie Knife Ever Offered:

Presented to President Roosevelt on March 3, 1909 (his last full day in office) by his friend James W. Gerard of the Supreme Bench of New York City and later Ambassador to Germany. The hilt is wrought in gold and platinum and ornamented with jewels exhibiting the arms of the United States, a wishbone, and the TR monogram on one side and two American Indians on the reverse. Two bear heads extend out from the base of the blade which is of the finest steel and is engraved as follows "Presented to Theodore Roosevelt by His Friend James W Gerard". Consigned directly by the descendants of the 26th President of the United States of America.

SEE OUR FULL PAGE AD IN THIS ISSUE OF
TRUE WEST FOR MORE DETAILS



Order Your Full-Color 3-Volume Set Catalog
Call (800) 238-8022 (\$60 Inc. S&H)

FULL-COLOR CATALOG ONLINE NOW!

WWW.ROCKISLANDAUCTION.COM



The World Leader for Quality
Collectable and Antique Firearms

RIAC IS ALWAYS ACCEPTING QUALITY CONSIGNMENTS -
ONE GUN OR AN ENTIRE COLLECTION!

Contact our Acquisitions Department by calling
800-238-8022 or Email: guns@rockislandauction.com

7819 42nd Street West, Rock Island, IL 61201

PHONE: 309-797-1500 • FAX: 309-797-1655

EMAIL: info@rockislandauction.com

Fully Licensed Class III Auctioneer